



ASL Technologies, LLC

FPRS-S200

Operations

and Maintenance

Manual



ASL Technologies, LLC
10525 W US Hwy 30, Bldg 3D Wanatah, In. 46390
Phone 219.733.2777 or Toll Free 888-333.2990
Facsimile 219.733.2779 or e-mail custsvc@aslfilter.com www.aslfilter.com

ASL Technologies, LLC Quality Policy

ASL Technologies, LLC was founded with the commitment to be the industry leader in product quality, customer service and customer satisfaction in the market places we serve. Our patented product line of Electrostatic Fluid Filtration equipment is designed, built, tested and delivered with these goals in mind.

Congratulations on the purchase of your new **Finite Particle Removal System™ (FPRS)**.

ASL Technologies FPRS S-Series Units provide state of the art fluid filtration that allows superior filtration capability at a minimum investment. Affordable electronics and compact design are combined to provide economic filtration without compromising the effectiveness of Electrostatics. Though compact in size, the S-Series can provide up to a year of replacement free filtration. It also provides effective cost recovery of valuable fluids and extension of component life in hydraulic, dielectric, and solvent systems.

ASL encourages you to read through this manual completely. Information has been provided in order that our customers can experience the maximum benefits resulting from extreme fluid cleanliness. Every situation cannot be anticipated and ASL is always available to help in any way possible. Critical information has been supplied to assist you with the theory, operation, and maintenance of the S-Series Finite Particle Removal System.™ Questions or concerns should be addressed to ASL.





Table of Contents

Subject	Page
Quick Startup Guide	3
Important Safety Information	4
Introduction/System Overview	7
Important Guidelines	9
System Safety Features, Indicators, Switches and Lights	9
Front Panel Controls/Indicators - Photo	12
Internal Components - Photo	13
Drip Tray and Float Switch - Photo	14
System Preparation	15
Installation Considerations	16
Fluid Maintenance	20
Cell Backflush Operation	21
Cell Removal/Installation	22
Water Absorber Replacement	23
Electrostatic Cell Rebuild Program	24
Warranty Information	25
Product Specifications	26
Parts Ordering Information	27
Spare/Replacement Parts List	28
Wiring Diagram	29
Cover Electrical Component Locations	30
Maintenance and Troubleshooting	31
Removal and Replacement of Components	37
Pump and Pressure Switch Adjustments	40
Scheduled Maintenance Tasks	41
Fluid Flow Diagram	42
Electric Motor Service Data	43
Hydraulic Pump Vendor Service Manual	44



Quick Startup Guide

This section is intended for experienced users only! Please be sure to read the entire manual!

1. Unpack FPRS Unit from shipping box/skid. There is a forklift pocket on the bottom of the unit. The open ends of the pocket are on the sides of the unit. Adjust your forks for a 23" width, outside to outside. The unit weighs 625 pounds empty, and approximately 733 pounds when full of fluid.
2. Open Top Cover by grasping rolled lip and lifting up, like a car hood. The white foam pad was inserted to protect the top cover safety switch during transit, and can be discarded. Swing the top cover all the way up until the prop rod engages into the locking slot. The cover is hinged at the top rear sides, and held closed with magnets. **Use extreme caution when the top cover is open, shock or jarring may cause it to close suddenly and could cause personnel and/or equipment damage.** To close the top cover, raise the cover an inch or so with one hand. With the other hand, grasp the upper rod between thumb and forefinger, and rotate it clockwise approximately ¼ turn. Slowly lower the lid to it's fully closed position.
3. With the Top Cover open, the Front Cover can be removed by pulling the top rolled edge toward you about 2 inches to disengage the magnets, and lift front cover clear of unit. The front cover fits outside the case sides and rests inside the case at the bottom. Note that the system has 4 full swivel casters, all with brakes.
4. Remove the backflush hose package. (Don't lose the backflush hose and fitting, you'll need them for unit servicing)
5. Check for any loose hoses, electrical connections, relays, etc. that may have occurred during shipping. (A laminated wiring diagram is pasted on the inside of the front cover)
6. Make sure the float switch is correctly positioned in the bracket/tray. The hinged float should be hanging down toward the bottom of the tray, such that a build up of fluid will raise the float and "close" the switch. The float switch stays in the tray, and is disconnected by pulling apart the 2-pin Molex connector on the side wall, near the bottom of the Water Absorber canister. Grasping the two drip tray knobs, slowly slide the tray out for servicing. When sliding the tray back in, make sure it goes all the way in, past the front edge of the false bottom.
7. Verify that the Water Absorber drain valve (3/8" gray hose) on the bottom of the canister is CLOSED.
8. Remove the plastic ½" NPT shipping plugs from the right side inlet and outlet bulkhead fittings. Plumb inlet and outlet hoses to your reservoir. Use Teflon tape or equivalent (Inlet to the lowest point on the reservoir, and outlet to the opposite side top of the reservoir) Make sure to drain any free water, which may have accumulated at the bottom of your reservoir.
9. Unwrap the power cord and connect to a grounded 10 amp 120 VAC outlet. **Note that the FPRS unit and your system reservoir must both have earth ground.**
10. Reinstall the front cover and close the top cover. (There is a safety switch on the top cover, that must be closed to allow incoming power to reach the power supply)

11. Turn the Power Switch to the “ON” position. The green “Power” lamp should illuminate. Note that all 5 Red “Low Voltage” lamps illuminate momentarily, and then go out.
12. The Fluid Delivery System (pump/motor) will immediately start and begin drawing fluid from your reservoir.
13. Note that the pump may need to be primed before any outlet flow is observed.
14. Your system was tested with fluid, but the water absorber element/canister and the Electrostatic cells are dry when you receive your unit. It may take a few minutes for them to fill, before any fluid output is seen. If output flow and/or pressure rise on the gauges is not observed within 3-4 minutes, turn power “OFF” and make sure the inlet hose is primed.
15. The FPRS-200 system has a flow rate of 3.4 GPM, and the system holds approximately 13 gallons of fluid.

IMPORTANT SAFETY INFORMATION

READ CAREFULLY BEFORE ATTEMPTING TO INSTALL, OPERATE OR MAINTAIN THE FINITE PARTICLE REMOVAL SYSTEM™. PROTECT YOURSELF AND OTHERS BY OBSERVING ALL SAFETY INFORMATION. FAILURE TO COMPLY WITH INSTRUCTIONS COULD RESULT IN PERSONAL INJURY AND/OR PROPERTY DAMAGE. RETAIN THESE INSTRUCTIONS FOR FUTURE REFERENCE.

SAFETY ALERT SYMBOL AND SIGNAL WORDS

The following safety alert symbol and signal words are used throughout this manual to call attention to and identify different levels of hazard and special instructions.



This safety alert symbol is used with signal words **WARNING** and **CAUTION** to call attention to safety statements.



WARNING! statements identify procedures or practices, which must be followed to avoid serious personal injury or loss of life.



CAUTION! statements identify procedures or practices, which must be followed to avoid minor personal injury or damage to this equipment.



ELECTRICAL SAFETY



WARNING! ELECTRIC SHOCK can kill. Your FPRS uses a high **Direct Current** voltage of **15,000 volts**. Do not touch live electrical parts. Always disconnect power source before working on the system.

Avoid accidental starting. Make sure unit is turned “OFF” and is unplugged or disconnected from its power source before beginning any maintenance tasks.

This product and the fluid reservoir it services, must both be earth-grounded to operate safely and properly.

Protect the power cable from coming in contact with sharp objects. Replace or repair damaged or worn cords immediately.

Safety devices such as interlocks, fuses and circuit breakers should not be disconnected or shunted out.



CAUTION! The power source must be fused for 10 amps.

1. The motor is designed for operation on the voltage and frequency specified on the motor nameplate.
2. Normal loads will be handled safely on voltages not more than 10% above or below the specified voltage.
3. Running unit on voltages not within range may cause overheating and motor burnout.
4. Heavy loads require the voltage at motor terminals be not less than the voltage specified.

Follow all local electrical and safety codes, as well as the National Electrical Code (NEC) and the Occupational Safety and Health Act (OSHA).

Install and maintain equipment according to USA Standard C1, National Electric Code.

Do not install FPRS unit's outdoors unless at least partially protected from the elements. Do not use in an excessively damp or wet location.

FLUID SAFETY



WARNING! Do not pump flammable or explosive fluids such as gasoline. Failure to follow this warning can result in personal injury and/or property damage and will void the product warranty.



CAUTION! Secure the discharge line before starting the system. An unsecured discharge line may whip, causing personal injury and/or property damage.

Explosive or flammable (flash point below 200° F) fluids must never be filtered with this product. **Electrostatic arcing is a potential ignition source.** Please refer to Fluid Specification prior to filtering fluid.

~ Do not exceed **45 psi** on any components in the system.

~ Protect fluid lines from damage or puncture.

~ Maximum fluid temperature should not exceed 165°F. The Electrostatic Cell body can distort at higher temperatures, draining the reservoir and creating a floor hazard and severely damaging the hydraulic system.



INTRODUCTION/SYSTEM OVERVIEW

The Finite Particle Removal System,™ Patent Numbers. 5,149,422, 5,242,587 and 5,891,315, (other Patents pending) uses the most advanced technology available to clean and reuse oil (i.e., transformer, hydraulic, turbine, lubricating) and solvents.

There are basically five (5) major factors contributing to the contamination of industrial fluids:

- Air
- Heat
- Water
- Particulate matter
- Oxidation of by products

Contamination of industrial fluids is a great concern because their condition is directly related to the condition of the overall system they function in. Controlling these five factors is foundational to maintaining a trouble-free system.

The following preventative measures do much to extend the life of the fluid and the hydraulic system. One must minimize the external ingress of air and particulate in the fluid. Breather bags and air intake filters have been used effectively for this purpose.

Maintaining the fluid temperatures within the specified limits can be achieved through proper care and maintenance of the cooling system. We have equipped your filtration system with continuous water removal capability to prevent build up due to condensation to keep the fluid dry.

Finally, the fluid must be kept as clean as possible, not only by removing particulate such as:

- Dirt
- Fibers
- Wear metals

Also, the **Submicronic Contaminants** such as:

- Silts
- Tars
- Varnishes

Tars and Varnishes are the byproducts of oxidation and typically occur and are encouraged because of the presence of air, heat and water. Oxidation is usually observed in lubricants and hydraulic oils and results in the formation and deposition of tars and varnishes on the components of the hydraulic system. Removing these contaminants continuously from the system will prevent the majority of problems that plague maintenance departments and cause expensive downtime. Keeping the fluid as clean as possible is what this product will accomplish for you and your company.



The FPRS is designed to connect directly to your machine's reservoir. The FPRS draws the fluid into its system using a pump that sends the fluid through a water absorber and Electrostatic Cell(s) to accomplish the cleaning process. The fluid is then discharged through an output hose and back into your reservoir.

The FPRS utilizes a combination of electrostatic and magnetic fields to remove submicronic particles from the host reservoirs fluid. This is accomplished by electrically influencing the particles in the oil to opposite polarities. These + and - influenced particles are attracted to one another and are retained by polyolefin foam used within ASL's patented Electrostatic Cell. Because the foam is polyofin, water in concentrations of 500 ppm or less will not disrupt normal operations, although microamp readings of the fluid will be slightly higher due to the conductivity of water.

The cell operates with alternating electrostatic and magnetic fields. If, for example, a particle is negative, it will seek the positive side of a magnetic plate. When the particles begin to collect together, one on top of the other, alternating as positive and negative particles, the polyofin foam pads inside the cell becomes a home for the particles and holds them in place. This collection of particles is a phenomenon known as "*strawing*."

Your FPRS comes equipped with a water absorption unit that can remove free and emulsified water down to 50 PPM. This feature covers a wide range of water problems.

Each fluid to be cleaned has its own characteristics, which may require modifications in magnetic field density and the dedicated collection media used within the electrostatic cell. The cell provided in your unit has been built to meet your specific requirements. Therefore, when discussing your unit with us or when ordering cells, be sure to state the correct model number of the cell. The model number is shown on a red tag on top of the cell, i.e. R61CS-115, R62CS-115, etc. Note that Phosphate ester fluid compatible cells have a "B" in the parts number, i.e. RB64CS-115, etc. Mineral oil cells have a Gray tube, and Phosphate Ester Cells have a Black tube.

The long-term benefits of continuous filtration with this product, as the contaminants are purged from your system, will become evident through reduced downtime and maintenance expenditures, extended machine life and greatly improved fluid life. Coupled with our water absorber, this product will protect the lifeblood of your hydraulic system from three of the five major factors that contribute to fluid degradation.

- Water
- Particulate Matter
- Oxidation by products



IMPORTANT GUIDELINES

*Oil temperature should not exceed 165°F for electrostatic cells.
(175°F for black tube Phosphate Ester Cells)*

Ambient air temperature should not exceed 160°F.

Viscosity of the oil to be cleaned cannot exceed 1800 SUS @ 100°F.

The minimum flash point of the oil should not be below 200°F

FPRS S-Series units will automatically restart if input power is momentarily lost.

Concentrations of **water should not exceed 500 ppm**. If in excess, a water absorber should be used to reduce the content to an acceptable level (less than 500 ppm) before the electrostatic cell is employed.

It is recommended the FPRS input hose be connected to or draw from the lowest point of the reservoir. Therefore, when hooking up to a reservoir for the first time or after a period of non-filtration, always drain free water from the bottom of the reservoir before using the FPRS.

The output hose should be returned to the highest point at the opposite end of the reservoir to ensure maximum distance between the input and output hoses.

When installing an FPRS S-Series unit on an elevated reservoir where the lowest fluid level of the reservoir is higher than the FPRS, it is recommended that shut off valves be installed in the line running from the reservoir to the FPRS pump (inlet). As well as the line running from the FPRS back to the reservoir (outlet).

When installing an FPRS S-Series unit above the highest level of fluid of the reservoirs it is required that the pump be primed. Once primed, the cabinet of the S-Series can be elevated as high as 24" above the highest level of the reservoir.

SYSTEM SAFETY FEATURES, INDICATORS, SWITCHES AND LIGHTS

Your FPRS S-Series unit comes equipped with several enhanced safety features and light/gauge indications that are designed to provide operator and environmental safety, ease of operation and troubleshooting. The following paragraphs contain a brief description of these features. Refer to the photos on pages 12, 13 and 14, and the wiring diagram on page 29. Note that the wiring diagram is also laminated and glued to the inside of the system front cover. The Maintenance section, beginning on page 31, provides further details on operation and troubleshooting.

1. POWER SWITCH

This switch controls power application to the system, and is in the power line after the 10 amp circuit breaker which is located next to the power switch. When the system is plugged in to a 120 VAC power source, power will be present on one side of this switch. Note that if incoming 120 VAC power is interrupted while the "POWER" switch in the "ON" position, the system will automatically restart as soon as incoming AC power is restored.

2. **SYSTEM CIRCUIT BREAKER**
Located between the ON/OFF switch and the Green Power lamp, the system circuit breaker is rated at 10 Amps.
3. **GREEN “POWER” LIGHT**
With the cover closed, and the power switch is ‘on’, power flows to the green “POWER” lamp, which illuminates to indicate power is applied to the system. The green POWER lamp is a neon tube lamp that is designed to glow for many hundreds of hours. These lights are “non-relampable” and must be replaced when defective. See the “MAINTENANCE” section for instructions.
4. **RED “LOW VOLTAGE” LIGHT(s)**
When the system is first turned on, or power is restored following a power interrupt condition, the 5 red “LOW VOLTAGE” lamps will illuminate briefly, and then go off. The “LOW VOLTAGE” lamps do not indicate trouble with the incoming 120 VAC power, but relate to the high voltage DC power supply, which supplies 15,000 VDC to the Electrostatic Cells. The signal to illuminate this light comes from a relay internal to the high voltage power supply (yellow wire) which opens at approximately 700 micro amps. If this lamp illuminates, it indicates that the high voltage DC power supply output voltage is low, and could be caused by a variety of reasons. When any of the “LOW VOLTAGE” lamps are illuminated, power to the pump/motor is interrupted. Refer to the “Maintenance” section.
5. **AMBER “BACKFLUSH” LIGHT**
This lamp comes on when the Electrostatic Cells need to be back-flushed with shop air. The signal to illuminate this light comes from a relay internal to the high voltage power supply’s (orange wire) which closes at approximately 500 micro amps. Note that all five power supplies orange wires are tied to the backflush light. The theory being that if one Cell needs backflushing, they all do. If this lamp illuminates, back-flush the Electrostatic Cells in accordance with the instructions on page 21 of this manual.
6. **RED “FLOAT SWITCH” LIGHT**
Illumination of this lamp indicates that there is either a fluid leak inside the FPRS, or the float switch has been upset during shipping, or recent movement of the unit. Note that this is a “latching” fault, and will not reset itself, even if the float switch re-opens. Power must be turned “OFF” and then back “ON” after correcting the fault. The float switch that activates this fault is located in the drip tray in the right front corner on the bottom of the FPRS cabinet. Note also that even though the pump stops, the 15,000 VDC is still applied to the terminals of the Electrostatic Cells while power is on.
7. **RED “OVER PRESSURE” LIGHT**
Illumination of this lamp indicates an overpressure condition has occurred. Note that this is a “latching” fault and will not reset itself, even if the overpressure condition clears. Power must be turned “OFF” and then back “ON” after correcting the fault. A pressure switch on the water absorber canister actuates the overpressure light. As in #6 above, 15,000VDC is still applied to the Electrostatic Cell while this fault is latched.
8. **“MICROAMP” METER**
The Microamp meter indicates the amount of high voltage DC power being consumed by the #1 Electrostatic Cell. Under normal conditions, the Microamp meter will indicate between zero and 400, and is a way to determine the general condition of the Cell. Note that high concentrations of water, or excessive accumulations of ferrous particulate can cause high microamp readings. At 500 microamps, the amber “BACK-FLUSH” lamp will illuminate, and at 700 microamps, the red



“LOW VOLTAGE” lamp will illuminate, the system will shut down, with the lamp remaining illuminated.

9. “ELAPSED TIME” INDICATOR

The elapsed time indicator shows, in hours and hundredths of hours, how long the system has been running. Note that power is supplied to the hour meter from the pump/motor start signal, and will only run when the pump is receiving power. The hour meter reads to 99,999.99 hours (11 years)

10. ABSORBER PRESSURE GAUGE

The Absorber pressure gauge shows system pressure at the entrance to the Water Absorber Canister. Under normal operating conditions (warm fluid, fresh water absorber element, fresh Electrostatic Cells, no output hose restrictions, etc.) the gauge will read approximately 10 to 25 psi. A higher initial reading may be caused by cold or thick fluid. Over time, it is normal for the gauge to indicate progressively higher pressure, due to accumulation of water in the water absorber element and/or excessive particulate accumulation in the Electrostatic Cell. At 35 to 38 psi. it's time to find the cause of the excessive pressure, which can only be caused by a clogged water absorber element or Electrostatic Cell, or some restriction in the lines downstream of the pump.

11. CELL PRESSURE GAUGE

The Cell Pressure gauge, shows pressure at the entrance to the cell inlet manifold. Under normal operating conditions, the cell pressure gauge will read 5 to 7 psi. less than the Water absorber pressure gauge.

12. REMOTE ALARM CONNECTOR

The Remote Alarm connector, located on the right side of the cabinet beneath the power cord entrance, is a two wire .250 male spade connector that can be interfaced to a remote alarm or PLC. The signal runs through two dry sets of contacts in relays CR-1 and CR-8. When the system is operating normally, these contacts are “closed.” In the event of any internal failure, these contacts “open.” If these connections are used, do not exceed 24 VDC.

13. OIL SAMPLE PORT

The oil sample port is located on the lid of the Water Absorber canister. This test port makes a convenient, leak and contamination free port to draw oil samples. The FPRS-S200 system uses a KP series thumb push sample valve, requiring no special tools or fittings to use. To sample, unscrew the cap on the sample valve, and push the thumb button in for a few seconds to flush the sample port. Using a clean sample bottle, remove the lid and invert it to prevent ambient dust or dirt from contaminating the sample. Fill the bottle to within ½” of the top. Immediately install the cap securely. Note that this port is before any FPRS filtration. Note also, that the FPRS must be running to draw the sample.

14. WATER ABSORBER DRAIN BALL VALVE

This (Normally Closed) drain valve, located at the bottom of the water absorber canister, is used to drain the canister when replacing the water absorber element. An 18” long gray drain hose is attached to the drain valve, and the hose end is folded and ty-wrapped when you receive your FPRS. The hose is stowed behind the absorber canister.

15. COVER SAFETY SWITCH

Once the power switch is placed in the “ON” position, power flows to one side of the cover safety switch. With the cover in the open position, power is interrupted, preventing operation of the FPRS.

FPRS-S200 Front Panel Controls and Indicators

(See pages 9 – 11 for detailed function)

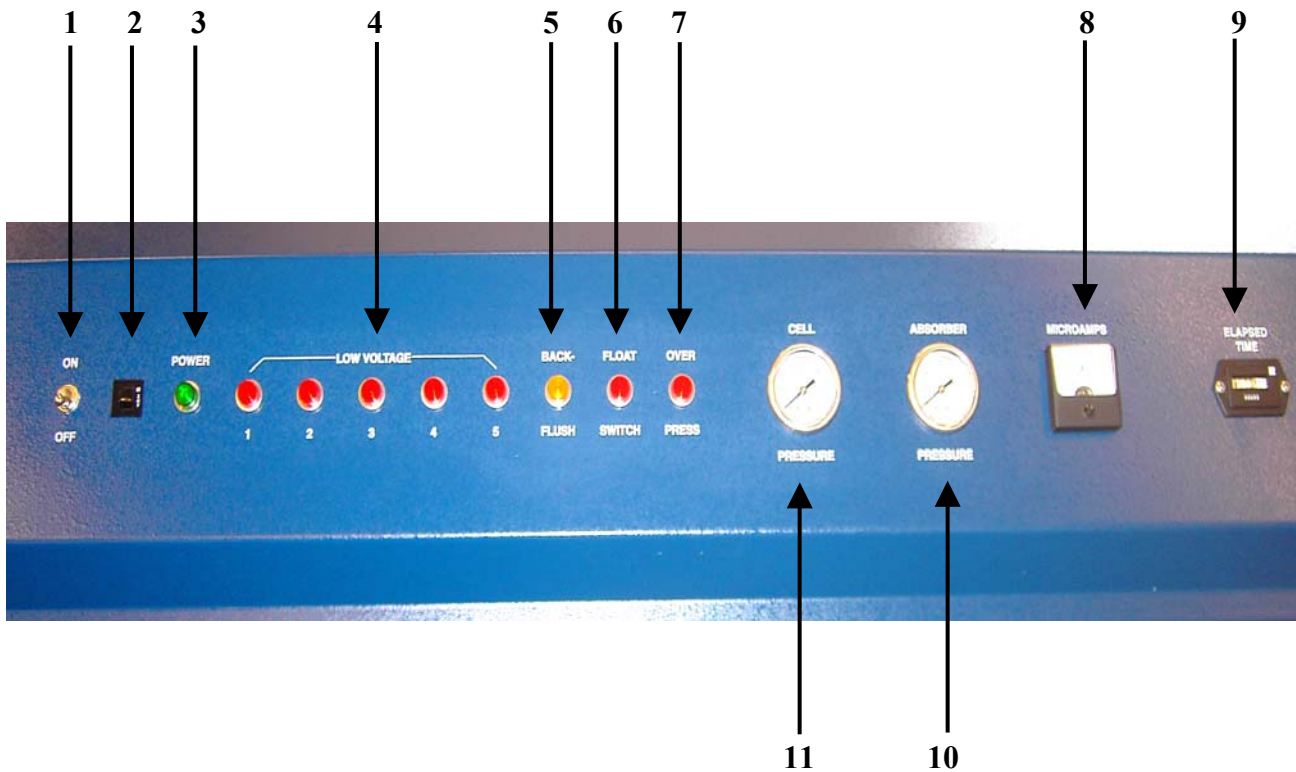

FPRS-S200 Internal Component Locations

Refer to descriptions on pages 9 – 11. Numbers in () refer to descriptions.

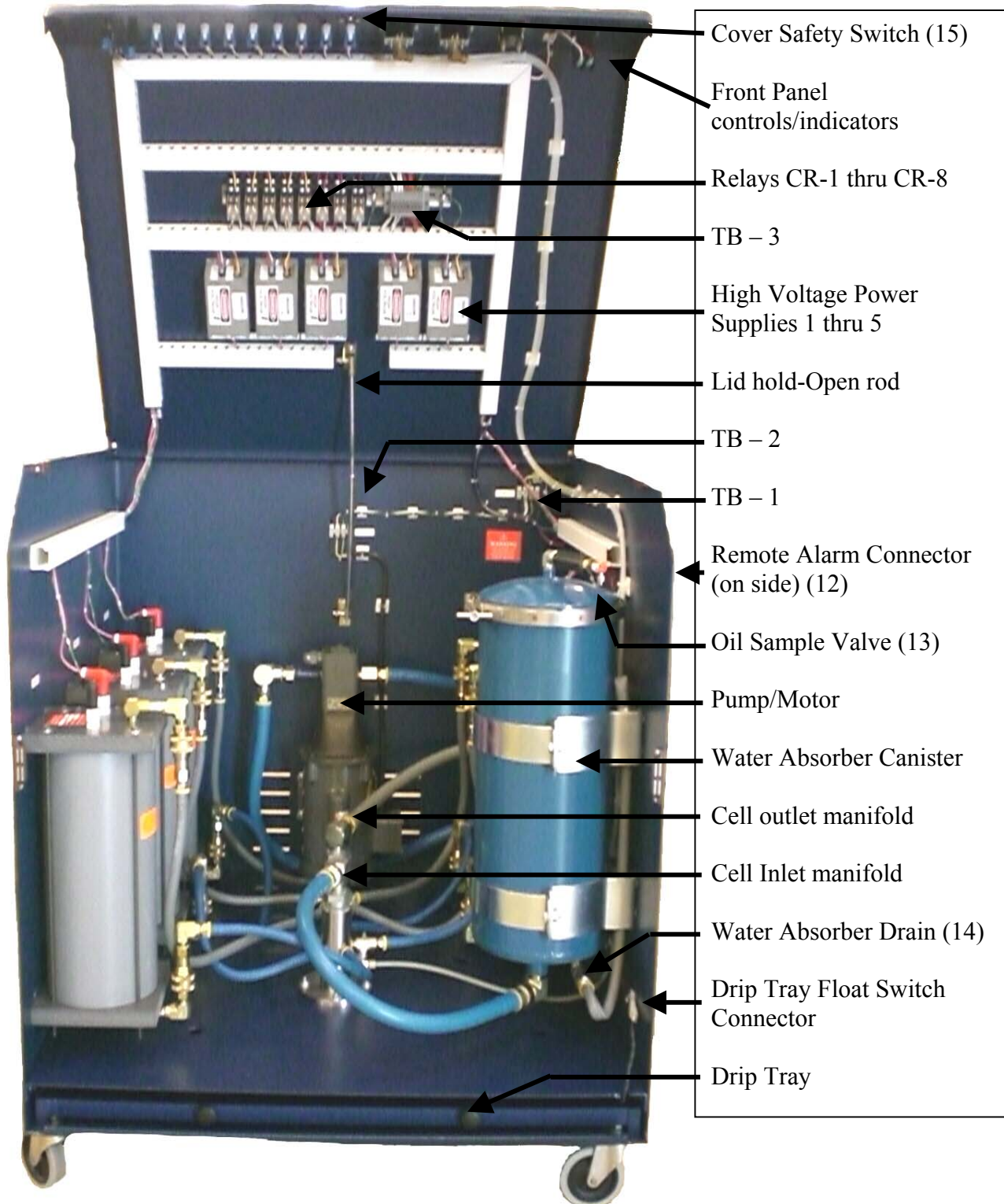

Drip Tray and Float Switch



**Disconnect 2
pin Molex**



**Grasp tray
by knobs.
Carefully
slide out for
service.
Switch stays
in tray.**



SYSTEM PREPARATION

NOTE: IT IS EXTREMELY IMPORTANT THAT THE FOLLOWING STEPS BE DONE IN ORDER TO ENSURE PROPER SET-UP AND OPTIMUM RESULTS FROM THE FPRS!



CAUTION! Before making power connections to this ASL unit, check the polarity of your power source. ***Also verify that earth ground is present.***

Open the hinged top cover, (two magnets hold the cover closed) and swing it back. Remove the front cover by pulling it toward you (also held in place with magnets) and lifting it out of the way, to expose the internal mechanisms.

Check the wire and hose connections to and from the FPRS. It is important that these connections are tight and have not shaken loose during shipment. Tighten the connections if they are loose. ***Do not over-tighten.***

Check the quick disconnects on the cell(s) to ensure that they are locked in place. (The outer ring of the quick disconnects slide back to lock and unlock the disconnect.)

The S-Series CABINET models will not operate with the front cover removed.

Take a sample of the fluid to be cleaned.

- ◆ Use a clean bottle to take the sample.
- ◆ The sample should be taken from the lowest point of the reservoir, preferably the drain cock or valve, because this is where the FPRS input hose will draw from. Free water should be drained from the reservoir before the FPRS is hooked up.
- ◆ Test the sample to ensure that the fluid does not surpass the guidelines of the system as set forth in this manual.
- ◆ For in-service oil analysis, a sample port has been provided, and is located on the lid of the water absorber canister. (See page 11 for sample port operations.)



INSTALLATION CONSIDERATIONS

APPLICATION COMPATIBILITY

While this product can provide effective filtration over a wide range of applications, there are some applications that are an exception.

- Type of fluid to be filtered.
- Contamination source or sources.
- The rate of contamination.

The following guidelines should be considered before installing this product.

1. Fluid Specification—this product is suitable for filtering nonconductive and semi-conductive fluids with viscosity rating less than 1800 SUS @ 100° F. ***Water based fluids cannot be filtered with this product.***

Typically compatible fluids include:

- Petroleum-based lubricants
 - Solvents
 - Synthetic lubricants
 - Dielectric fluids
 - Phosphate Ester, fireproof fluids (Requires different Electrostatic Cell, hoses, seals, gaskets, etc.) Phosphate Ester Cells are BLACK with White ends.
2. Contamination Type—non-discrete type contamination cannot be filtered with electrostatics. This includes contamination from other fluids or chemical property altering contaminants. Systems with chronic water ingress cannot be filtered effectively unless the source of water can be eliminated or greatly reduced to less than 500 ppm.
 3. Contamination Rate—systems that produce excessive contamination may quickly overwhelm this product, especially if the contaminant is conductive (i.e. EDM, grinding and polishing systems, etc..)



The FPRS is now ready to be charged (filled) for operation and tested to ensure that no connections have loosened during shipment. The FPRS should be charged with the same fluid it has been designated to clean.

INSTALLATION

APPROPRIATE LOCATION

Avoid locations that expose this product to excessive moisture and explosive environments. This product generates an electrostatic field that may disturb or damage sensitive electronic equipment. Also, remember that access to this product is required periodically to replace the electrostatic cell(s) and Water Absorber element. Finally, avoid installing in high traffic areas where this product may be easily damaged by vehicles, forklifts, etc.

SYSTEM CONSIDERATIONS

1. Main Power Supply Source

- ◆ 120 volts AC, 60 Hz, single phase.
- ◆ 10 amps Circuit Breaker.
- ◆ 16 ga. Power cord provided.
- ◆ Earth Ground.
- ◆ Vertical Orientation.
- ◆ Ambient temperature less than 160°F.

2. Fluid Delivery

Pump/Motor –The self-contained pump and motor delivery system allows for continuous filtration, even during machine downtime. Installation is convenient and maintenance does not require shutting down the hydraulic system. A pump /motor assembly is provided which is designed to be compact, and is for continuous-duty, maintenance free and has been sized for the correct flow rate.

3. Hydraulic Connections

All the connections between the reservoir and the cabinet can be with hard-piping or hose connections. On the S-Series units, ½ ” NPT bulkhead fittings are provided for your convenience on the right (power cord) side.



4. Mounting Surface

The S-Series Cabinet Model has cooling vents on the back of the cabinet, behind the Motor. These slots must remain open and free of restrictions, which could interrupt the flow of cooling air to the motor. The system must be kept in a level position when operating.

5. Remote Alarm

If a signal is desired to provide remote indication of an alarm condition, the S-Series Cabinet Models provide dual quick—connect interface with two internal dry relay contacts to interface with a signal not exceeding 24 volts. The relays are closed during normal system operation. During an alarm condition, such as overload, the relay will open. A second access hole is provided if hardwiring is required by your electrical codes. These connections are located on the right side of the cabinet, just below the power cord.

6. Water Absorption

Equipping the filtration system with water absorption capabilities maintains constant fluid dryness and prevents moisture build-up from condensation in the reservoir. The S-Series units are equipped with a water absorber unit that is installed between the fluid delivery system (pump) and the cell(s). This filter will also trap contaminants 5 microns and larger, and should be replaced whenever water content increases, or pressure rises above 35 - 38 psi. Replacement elements are available from ASL.

HOSE CONNECTIONS

It is recommended that connections to reservoirs be made with quick disconnects or hard plumbed to minimize ingress of contaminants when hooking up and operating the FPRS.

- ◆ Connect the input and output hoses to the FPRS.
- ◆ Connect the input hose to the fluid reservoir. If there is no place to secure the hose, simply place the hose in the fluid near the bottom of the tank.
- ◆ Place the output hose into the fluid reservoir at the top of the tank
- ◆ When installing an FPRS S-Series on an elevated reservoir where the lowest fluid level of the reservoir is higher than the FPRS, it is recommended that shut-off valves be installed in the line running from the reservoir to the FPRS pump (inlet). Also, the line running from the FPRS back to the reservoir (outlet).



CAUTION! HANDLE THE HOSES SO THAT SPILLS CANNOT TAKE PLACE.

SYSTEM START-UP

- ◆ Connect the FPRS to a grounded **120VAC**-power source.
- ◆ **Both the FPRS and the hydraulic system reservoir must have earth ground.**
- ◆ Ensure that the shut-off valves on the input and output lines are open.
- ◆ Locate the drain valve on the bottom of the water absorber canister and verify it is in the closed position.
- ◆ Place the front cover in position and close the top cover.
- ◆ Turn the “POWER” switch on the front panel to the “ON” position. The green “POWER” lamp will illuminate and remain on. Note that the red “LOW VOLTAGE” lamps will flash on, and then remain off.
- ◆ The FPRS pump will start running, and draw fluid from the reservoir into the FPRS.
- ◆ Check for any external leaks.
- ◆ Turn the “POWER” switch “OFF.”
- ◆ Open the top cover and remove the front cover.
- ◆ Check to ensure there are no leaks internally.
- ◆ Locate the red tag on top of the Electrostatic Cell. Fill in the “**Date Installed**” in the space provided. This will assist you in determining when an annual cell exchange will be required.
- ◆ Replace the front cover and close the top cover.

You are now ready to begin normal operations.

Your FPRS system has been designed to operate continuously on a fluid reservoir with little operator attention. However, it is recommended to check the control panel daily to monitor system condition. (See page 41 for Scheduled maintenance Tasks.)

FLUID MAINTENANCE

The following recommendations are made in the interest of maximizing the benefits available with the S-Series FPRS system.

1. Periodically monitor the condition of the machine fluid. The following is a list of recommended tests that should be performed:
 - ◆ Viscosity
When compared to values for virgin oil, the viscosity gives an indication of excessive thinning or thickening resulting from oil breakdown.
 - ◆ TAN
When compared to values from virgin oil, an increase on the TAN indicates oil serviceability with regard to oxidation or contamination with an acidic product.
 - ◆ Particle Count
Monitors the oil cleanliness level to provide indication of filter efficiency and potential wear failures.
 - ◆ Water
Indicates the presence of moisture of coolant in the oil. For detection of water content below 1000ppm, the Karl-Fischer method can be used.
 - ◆ Spectrochemical Elemental Analysis
The presence of elements in solution, i.e. additives, wear metals and contamination elements.

FT-IR—Estimation of oxidation levels.

PIXIE—Analysis of contaminant residue on patches.
3. When the condition of the oil is in question, it is usually more economic with small reservoirs to simply replace the oil than it is to spend money on extensive testing. Tests should be used to analyze potential problems in the machinery, not necessarily to determine oil life in these cases.

CELL BACKFLUSH OPERATION

Backflushing of the cell is unique to ASL's Finite Particle Removal System™. This operation allows the cell to be reused without being replaced under normal use. (*Under normal operation, Electrostatic Cell and water absorber should be changed annually*)

When the cell becomes filled with contaminants, (about 500 microamps) and/or the amber "BACK-FLUSH" lamp illuminates, the cell(s) need to be backflushed.



WARNING! Turn OFF the FPRS on the control panel and at the electrical source. Disconnect the input and the output hoses from the cell and set aside. Connect a backflush hose to the quick disconnect at the bottom of the cell.

Place the end of the bottom backflush hose into a suitable container.

Using a second backflush quick disconnect fitting, connect plant air supply (**REDUCE TO 10 PSI**) to the quick disconnect at the top of the cell. Allow 10 psi of air to flush the contaminants out of the cell and into the pail for disposal. Leave the air pressure on until contaminants are no longer dispensed out of the backflush hose. (about 10 minutes)



CAUTION: BACKFLUSH HOSE WILL JUMP AROUND AS AIR REACHES IT!

Remove the backflush hoses and replace the input and output hoses to the top and bottom of the cell at their original configuration, blue hose to the bottom of the cell disconnect and gray hose to top of cell. (The top of the cell connects directly to the outlet manifold)

Turn **ON** the electrical service to the FPRS™

Restart the system and check the amber "BACK-FLUSH" light to ensure that it has gone out. If it remains on, refer to the "**Maintenance**" section of this manual.

Observe that the microamp meter is now below 500 microamps.

Over time, backflushing may no longer be effective, and the Electrostatic Cell must be replaced.

CELL REMOVAL/INSTALLATION

Under normal operating conditions, cells should be changed **annually**. When you replace your electrostatic cell, perform the following steps:



1. **WARNING!** Turn **OFF** the FPRS on the control panel and at the electrical source.
2. Open the top hinged cover, and remove the front cover.



3. Disconnect the high voltage wires as follows:



4. **WARNING!** Short across the positive and negative electrodes using a screwdriver with an insulated handle to dissipate static electricity.

5. **WARNING!** Each cell has a **positive (red)** lead and a **negative (green)** lead connected to it. **NEVER** touch both leads at the same time.

6. Disconnect the high voltage wire connections leading to the top of the cell; **using one hand**, grasp the boot connected to the green wire and pull up. Repeat with the boot connected to the red wire.

7. Remove the input and output hoses by releasing the quick disconnects.

8. Loosen 4 attaching screws from outside of the cabinet and lift the cell out of the cabinet.

9. Replace with a new or rebuilt cell. Ensure that the cell is inserted correctly with high voltage electrodes pointing upwards.

10. Attach quick disconnects with blue hose to the bottom of the cell and gray hose to the top of the cell.

11. Replace the high voltage wires to the cell. **Red is positive, Green is negative.** The label at the top of the cell notes the POS and NEG electrodes. Be sure to fill in the “**Date/Hours Installed**” on the cell tag.

12. Replace the front cover and close the hinged top cover.

13. Restart the FPRS and operate system for a few minutes. Ensure that fluid is being dispensed through the output hose.



14. **WARNING!** Once fluid is dispensed through the output hose, turn **OFF** the FPRS on the control panel and at the electrical source.

15. Open the top cover and remove the front cover and check for leaks. Replace the front cover and close the top cover. The FPRS is now ready to resume operation.

WATER ABSORBER ELEMENT REPLACEMENT



If the pressure gauge on the water absorber element is above its normal running pressure, it may need to be replaced. (>35 psi)

WARNING! Turn **OFF** the FPRS on the control panel and at the power source.

Open the top cover, and remove the front cover.



Locate the absorber drain hose. (It is folded over and tie-wrapped)
 Cut the tie-wrap and place the hose in a pail.
 Open the drain valve on the bottom of the absorber canister.



Loosen and remove the V-band Clamp at the top of the canister and remove the lid.

Remove the element hold down bolt, and lift out the old element by the wire handle.

Unpack the new element and install into the canister.

Re-install the element hold down bolt, hand tight.



Clean the 'O' ring, and apply a thin coat of your oil. Replace the canister lid and clamp.

Close the drain valve on the bottom of the absorber canister, and stow the drain hose.

Replace front cover, and close top cover.

Activate the main power source, and then turn **ON** the power switch on the control panel.



After fluid is dispensed through the output hose, shut down the system and check for leaks.



Electrostatic Cell Rebuild Program

The Electrostatic Cells in your FPRST™ (Finite Particle Removal System) are designed to provide many hours of superior filtration. Like anything else, it occasionally needs care and maintenance. It is strongly recommended that the Cell be replaced once each year to insure optimum cleaning performance. The re-build/exchange program has been organized to provide minimum downtime and maximum performance.

When you receive your replacement Electrostatic Cells, please note that the red tag affixed to the top of the cell contains part number information, as well as the date the cell was made. A blank area is left open for you to fill in the date the cell was installed in your system. This will help you determine when the cell should be exchanged.

When you are ready to replace your Electrostatic Cell, please follow these steps:

1. Look at the red tag on the top of the cell to locate your part number. (R61CS-115, for example)
2. Send your P.O. to ASL via Phone, Fax, mail, or e-mail (custsvc@aslfilter.com) with the quantity and part number requested.
3. When you receive your cell, install it in your unit, and return the used cell to ASL in the shipping box. (Please backflush the return cell for 10 minutes at 10 psi to drain as much fluid as possible.)

You should order your re-built cells early so you won't be down, waiting for your new Cells to arrive. Please remember to **backflush returned cells** prior to sending them back to us. This will save you on shipping costs, (a re-built cell weighs 16 pounds, and most Returned cells weigh in at 28 pounds) as well as saving the environment, as we have to dispose of the used, contaminated oil and internal components.

Note that if the used cells are not returned to us within 30 days, you will be invoiced separately for a core charge for each cell not returned



ASL Technologies, LLC
10525 W US Hwy 30, Bldg 3D Wanatah, In. 46390
Phone 219.733.2777 or Toll Free 888-333.2990
Facsimile 219.733.2779 or e-mail custsvc@aslfilter.com www.aslfilter.com

WARRANTY INFORMATION

ASL Technologies, LLC, (“ASL”) warrants this product to be free from defects in material and workmanship for a period of one (1) year, from date of shipment, excluding expendables, in accordance with the following terms and conditions.

This warranty extends only to the original purchaser (“owner”).

This warranty does not include damage to the product resulting from accident, misuse or abuse, improper installation or operation, lack of reasonable care, or unauthorized repair or alteration.

Should this unit fail during the warranty period, ASL will repair or replace it at our option. Replacement products supplied under this warranty may be new or rebuilt at our option. Labor charges will be without cost to the purchaser (owner) during the first ninety- (90) days of the warranty period, up to 500 hours of operation. Owner will be responsible for all labor charges after this period. Owner will pay for the expense of delivering the product to ASL for warranty work, and expense of returning it to the owner after repair or replacement. ASL will assume no field expense for service or parts unless authorized in advance.

This warranty is the only warranty extended by ASL to suppliers and/or purchasers of this product. No other warranty, written or oral, is authorized. ASL disclaims all other warranties; express or implied that arises by operation of law, except that implied warranties of merchantability or fitness for a particular purpose are limited to the duration of the warranty period. ASL shall not be liable for any incidental, consequential or other damage that may have resulted from any alleged breach of warranty, including any cost or expense of providing substitute equipment or service during periods of malfunction or non-use.

Some states do not allow limitation on how long an implied warranty lasts or the exclusion limitation of incidental or consequential damages, so the above stated limitations or exclusions may not apply to you.

This warranty gives you specific legal rights, and you may also have other rights, which vary from state to state.

For instructions on how to obtain warranty service, contact:

ASL Technologies, LLC
10525 W US Hwy 30, Bldg 3D, Wanatah, In. 46390
Phone 219.733.2777 or Toll Free 888-333.2990
Facsimile 219.733.2779 or e-mail custsvc@aslfilter.com



PRODUCT SPECIFICATIONS FPRS S-200 Cabinet Units

PHYSICAL DIMENSIONS:	
Filter Cabinet:	36" High x 36" Wide x 36" Deep
Cabinet Construction:	10 Gauge Steel
Water Absorber Canister:	18" High x 8" Diameter
SHIPPING WEIGHT:	675 pounds
GROSS WEIGHT DRY:	625 pounds
GROSS WEIGHT WET:	733 pounds
MOTOR:	1/3 HP 1725 RPM
	120 VAC 60 Hz, single phase
	4 amps continuous 6 amps start up
PUMP:	200 GPH w/100 SUS Fluid @ 1725 RPM
	1/2" NPT, Inlet & Outlet Ports
WATER ABSORBER:	5 micron wood/paper element
	(Mineral Oil Units)
INLET & OUTLET	
CONNECTIONS:	1/2" NPT Bulkhead Fittings
SYSTEM VOLTAGE:	
Input Voltage	120 VAC 60 Hz, single phase +/- 10%
Circuit Breaker	10 Amps.
Output Voltage of Power Supply	15KV Nominal 1.9 miliamp (+/-600uA)

Manufactured in the U.S.A.



ASL Technologies, LLC
10525 W US Hwy 30, Bldg 3D Wanatah, In. 46390
Phone 219.733.2777 or Toll Free 888-333.2990
Facsimile 219.733.2779 or e-mail custsvc@aslfilter.com www.aslfilter.com

ORDERING SPARE AND REPLACEMENT PARTS

A Spare Parts List for your FPRS is included on the following page. Prompt service can be given for spare or replacement parts if ASL has the following information:

1. The part number(s) of the item(s) you need. The Spare Parts List includes the most frequently requested items.
2. The quantity needed. Please remember to order spares, if needed.
3. Order fulfillment information:
 - ✓ Preferred shipping carrier information (ASL is an On-Line daily UPS shipper)
 - ✓ Ground, Next Day, Second Day, etc.
 - ✓ "Bill To" Address
 - ✓ "Ship To" Address (we cannot ship to a P.O. Box)
 - ✓ Purchase Order Number

Parts will be invoiced F.O.B. Wanatah, IN. at the prices in effect at the time of the shipment. Terms will be Net 30 days. We also accept Visa, MasterCard, and American Express.

Order Address: **ASL Technologies, LLC**
Parts Department
10525 W. US Hwy 30, Bldg. 3D
Wanatah, IN. 43690

Telephone: **219.733.2777**
Toll Free: **888.333.2990**
Facsimile: **219.733.2779**
E-Mail: **custsvc@aslfilter.com**
Internet: **www.aslfilter.com**



FPRS S-200 Cabinet Spare / Replacement Parts

DESCRIPTION	PART NUMBER
Call ASL for any parts not listed	
High Voltage Power Supply (ALL)	CS-2223-P8
S-200 Pump/Motor/coupler ASSY	SG-0570-GOV
S-200 Pump only	SG-0570
S-200 Motor only (Baldor)	CL-3501
S-200 Coupler only	Lovejoy 1/2"
Water Absorber Element	WAEB-18
Water Absorber can 'O' ring (Buna)	R40-0009
Electrostatic Cell	R61CS-115 (See red tag on top of cell for your exact part number)
Pressure Gauge	E 1401 UC
Lid Safety Switch	07F 038
Lid/Front Cover Magnet	11242
Hour Meter	711-0130 (60Hz)
Microamp Meter	S13260
S-200 Service Manual (This Manual)	S-200 Series Cabinet Service Manual
Laminated wiring diagram (Inside front cover)	S-200 Series-Wiring Diagram
Power Switch	7500K14
Circuit Breaker	4AO45
Green Power Lamp Assy	1052-QC5
Amber Lamp Assy - Backflush	1050-QC3
Red Lamp Assy (Low Voltage, Float Switch, Over Pressure)	1050-QC1
Relay, CR-1 through CR-8	LY2 – 120VAC, 10 Amp contacts
Float Switch	M8700
Pressure Switch	PDA-4-4R4M-C-FL
Remote Alarm Connector	DC68-2-2
Power Cord – 9'	70355 K34
Oil Sample Test Port (Push to test type-Viton)	KP14N-V-1
Cell Q.D. Female	F-3HF3
Pressure Gauge tubing	PT24004NA-100
Cell Inlet (Blue) hose 3/8" (Aeroquip)	FC662-06 BLU
Cell Outlet (Gray) hose 3/8" (Aeroquip)	FC662-06 GRA
Lid hold open prop rod assy	LOK-0401024

FPRS-S200 Wiring Diagram

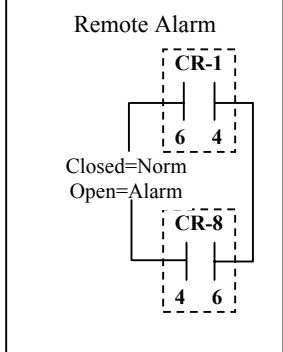
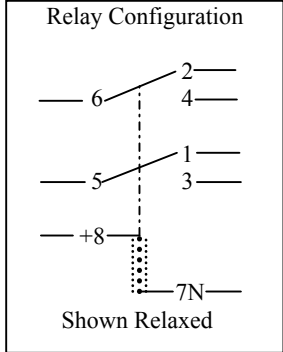
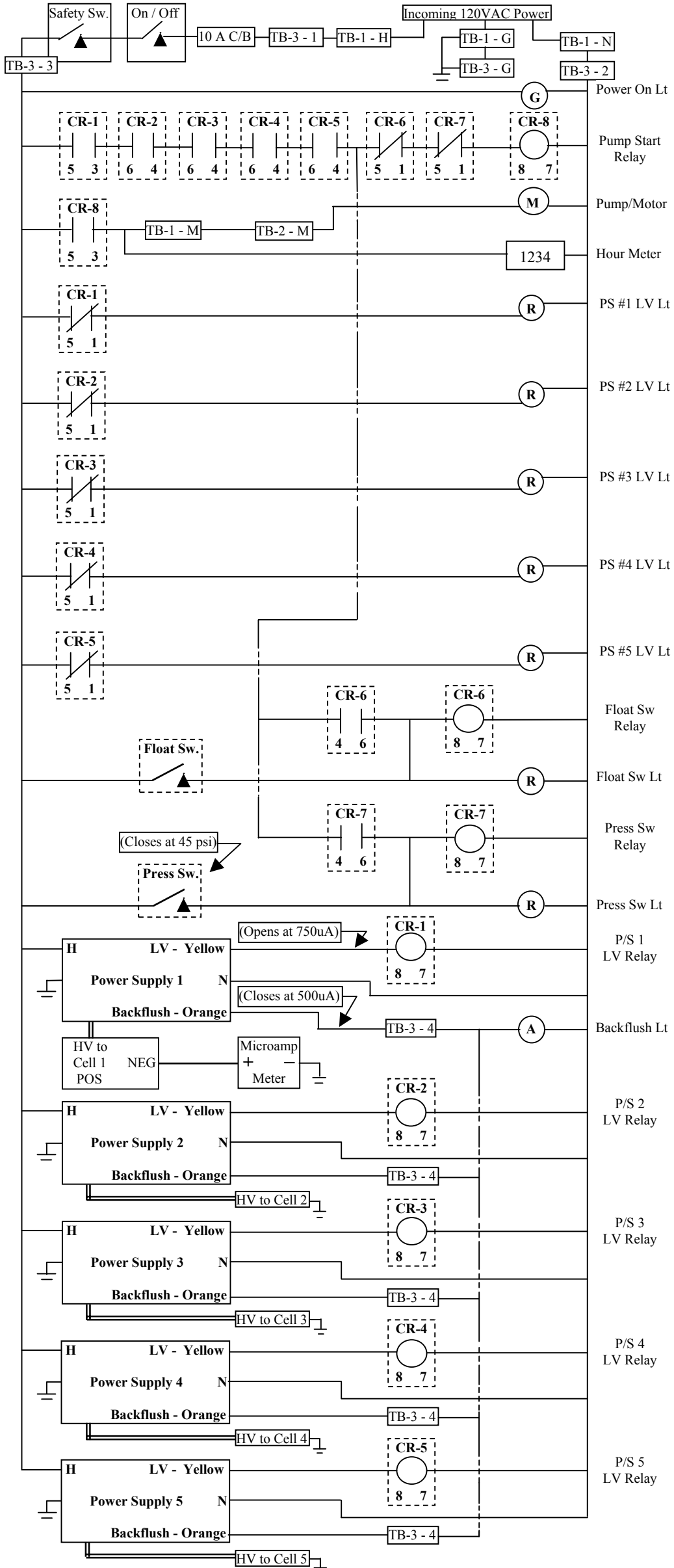

Cover Electrical Component Locations

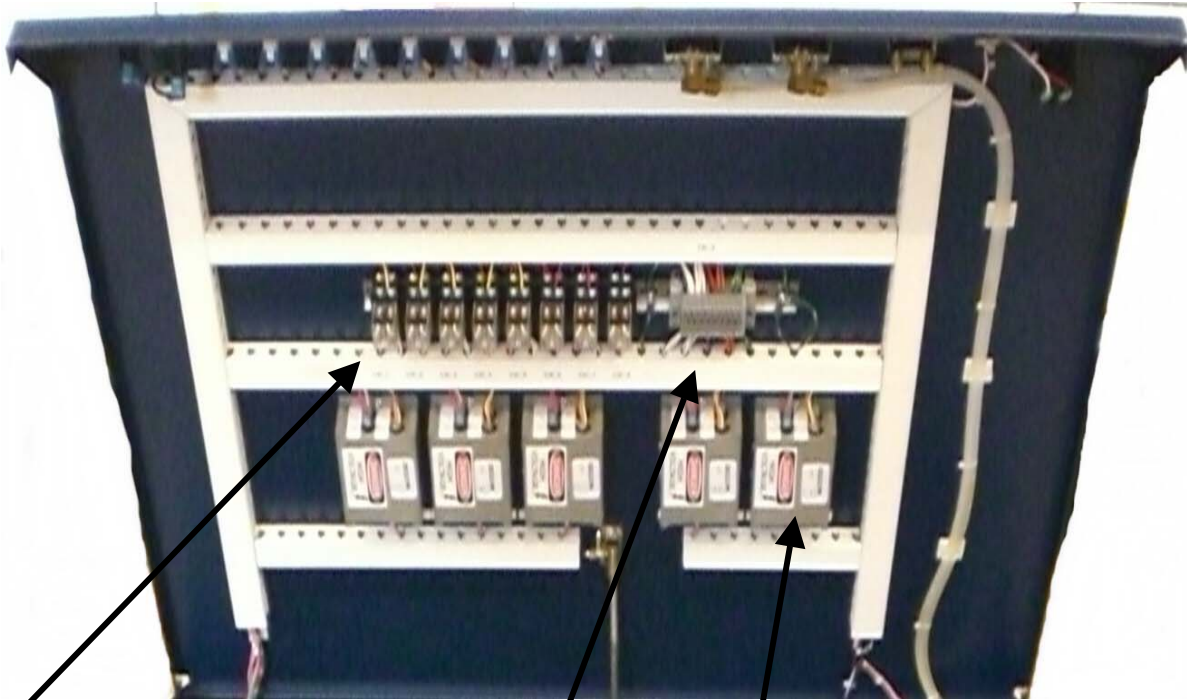

Relays- CR-1 thru CR-8 Left to Right

TB-3

1 – Incoming 120VAC + from TB-1 H - Black

2 – Neutral - White

3 – Switched Power Red – Black

4 – Backflush – Orange

G – Grounds – Green

Power Supplies – P/S-1 thru P/S-5 Left to Right

MAINTENANCE AND TROUBLESHOOTING

The FPRS system is designed to give years of trouble free service with little attention. The front panel lights, microammeter and system pressure gauges will show signs of trouble, weather caused by contaminant buildup or component failure. The system was designed to make troubleshooting and repair as painless as possible, while providing maximum safety, system protection, and trouble indication. The following theory of operation and troubleshooting guides make reference to drawings and charts located within this manual. Please refer to them to reinforce your knowledge of this product. Remember that ASL Technicians are just a phone call away, should you need any advice or assistance.

ELECTRICAL THEORY OF OPERATION

Refer to the wiring diagram on page 29 (the wiring diagram is also laminated and pasted inside the front cover) The FPRS-S-200 series units use the following wiring conventions:

1. Black wires – 120VAC Power
2. White wires – 120 VAC Neutral
3. Green Wires – Ground
4. Yellow wires – H.V. Power Supply Low Voltage alarm circuit
5. Orange wires – H.V. Power Supply Backflush alarm circuit
6. Blue wires – Remote Alarm Circuit
7. Red wires- 120VAC switched/signal

Exceptions:

- a. The green wire on the pressure switch is capped and not used, but will have 120VAC present when the pressure switch is open (normal condition)
- b. The float switch comes standard with two white wires pre-installed on the switch. These white wires pass 120VAC through the switch when closed.
- c. The red (pink) Hi Voltage wires coming out of the bottom of the power supplies carry 15,000 VDC to the Electrostatic Cells.

THE 120VAC POWER CIRCUIT

120VAC power from the incoming power cord/source goes first to a four-position terminal strip on the back wall of the cabinet, (TB-1) above and to the right of the pump/motor. From there, power (black wire) runs to another terminal strip (TB-3) located on the inside of the top cover, to the right of the relays. Power then runs to the 10A circuit breaker on the front panel. From the circuit breaker, power is fed to the ON/OFF switch on the front panel. Power then flows to one side of the cover safety switch. The other side of the safety switch then goes to TB-3 – 3, and from there spreads to CR1-5, CR8-5, CR2-5, CR3-5, CR4-5, CR5-5, Float switch power (black) wire, the Pressure switch power wire, the 120VAC “in” connector on all 5 High Voltage power supplies, and finally to the “Power” lamp on the front panel. Note that the normally closed contacts of CR1 thru CR5, pins 5 & 1 will momentarily pass 120VAC to the red “Low Voltage” lights on the front panel. Once the H.V. power supplies receive power, a normally closed relay inside the power supply sends power to the coil of CR1 thru CR5, via the yellow wires. The action of CR1 thru CR5 energizing starts the sequence of events to run the system. Note that as soon as the power supply receives incoming power, 15,000 VDC is immediately applied to the terminals of the Electrostatic Cells!

With CR1 thru CR5 coils energized, the contacts of CR1-5&3 close, along with CR2-6&4, CR3-6&4, CR4-6&4, and CR5-6&4, allowing power to flow through the normally closed contacts of CR6- 5 & 1, and CR7- 5 & 1, thus energizing the coil of CR8. Once CR8 closes, power is allowed to flow through the (now closed) contacts of CR8-5 & 3. Power then simultaneously goes to the hour meter on the front panel and through terminal strip TB-1 –M and to TB-2 –M to start the pump/motor. At the same time CR-1 thru CR-5 close, the normally closed contacts of CR1 thru CR5, pins 5 & 1 open, turning the red “Low Voltage” lights on the front panel off. At this point, the system is operating normally. Green “Power” lamp lit, hour meter running, pump/motor running, 15KV supplied to the Electrostatic Cells.

TROUBLE INDICATING CIRCUITS and TROUBLESHOOTING

LOW VOLTAGE INDICATOR

The red “Low Voltage” lights indicate that the Electrostatic Cell High Voltage DC power supply is no longer putting out enough voltage to hold particulate trapped within the Electrostatic Cell. Note that these lights will illuminate briefly when power is first turned on.

The low voltage indication is controlled by a normally closed relay within the high voltage power supply. This relay (the yellow wire coming out of the power supply) remains closed until the power supply senses a load of 700 (or more) microamps. At that point, the internal relay opens, and the 120 VAC that was present on the yellow wire drops to zero. This starts a chain of events that commences with the coil of CR-1 relaxing. When CR-1 opens, contacts CR1 – 5 & 3 open, stopping the flow of power to the coil of CR-8, which in turn stops power to the hour meter and pump/motor. At the same time, the contacts of CR1 – 5 & 1 close, allowing power to illuminate the low voltage light for power supply #1. The other four power supplies work in the same manner. CR-2 for power supply 2, CR-3 for power supply 3, etc. Note also that power supply 1 is connected to Electrostatic Cell 1, power supply 2 to Electrostatic Cell 2, on so on. Refer to the wiring diagram on page 29 of this manual. The schematic is also laminated and glued to the inside surface of the front cover.

The idea here is that if any one of the high voltage power supplies no longer has enough voltage output to keep particulate trapped within the Electrostatic Cell, the pump needs to be stopped immediately. The backflush procedure depends on this phenomena to operate, i.e. Once power is removed from the cell, contaminant can then be blown out with shop air.

The system will try to keep running, however, and the power supply will reset itself and try to turn on again. If the conditions that caused the low voltage indication are still present, the pump will stop and start as the power supply tries to reset itself. If you observe a “flashing” low voltage light, you should shut down the system immediately and investigate the cause. Remember that the low voltage indicator light should reflect the microamps being consumed, so a low voltage light should be confirmed by observing the microammeter indicating 700 or more microamps.

Causes for a low voltage light. The low voltage light can be caused by one or more of the following:

1. **Shorted Electrostatic Cell.**

The Electrostatic Cell can short due to ingestion of water, or accumulation of an excessive amount of particulate, particularly ferrous particulate.

- a. Turn power off and un plug the FPRS from the power source.
- b. Using a screwdriver with an insulated handle, short across both POS and NEG terminals of the Electrostatic Cell to dissipate any static electricity.
- c. Remove the red POS spark plug boot/terminal from the Electrostatic Cell.
- d. Remove relay CR-8 to prevent the pump from starting.
- e. Re-connect power, and turn on the power switch. Note that you will have to defeat the cover safety switch to continue. **USE CAUTION**
- f. If the low voltage light is now off, the Electrostatic Cell is shorted, and should be backflushed and/or replaced.
- g. If the low voltage light is on with the corresponding Cell disconnected, the power supply is defective and should be replaced.
- h. Note that it is possible to have both a shorted Cell and a bad power supply at the same time. If you have a spare cell, try it first before replacing the power supply.
- i. Note that a defective CR-1 thru CR-5 relay and associated wiring can also cause a low voltage indication.



2. **Defective Power Supply.**
- If the internal, normally closed low voltage relay in the power supply is defective, a low voltage indication will result. Trouble shoot this failure as follows:
- 
- a. Turn power off and un plug the FPRS from the power source.
 - b. Remove relay CR-8 to prevent the pump from starting.
 - c. Remove the POS spark plug boot/terminal from the Electrostatic Cell associated with the Low Voltage light. The convention is P/S #1 is related to Cell #1 and Relay CR-1. P/S #2, Cell #2, Relay CR-2, etc.
 - d. Restore power to the FPRS and turn the power on. Note that you will have to defeat the cover safety switch to continue. **USE CAUTION**
 - e. Using an AC voltmeter, check for 120VAC at the “L+ HOT” terminal on the high voltage power supply in question.
 - f. If OK, check for 120VAC on pin 8 (yellow wire) of the associated relay. (CR-1 for P/S #1, etc.)
 - g. If 120VAC is present at the power supply L+ HOT terminal, and no power is present on the yellow wire, the power supply must be replaced.
 - h. If 120VAC is present on both the above terminals, check for 120VAC at pin 8 of the appropriate relay. If no voltage present, repair wiring. If 120VAC is present, check for voltage at pin 3 of CR-1. If no voltage present, replace Relay CR-1.
 - i. Note that all relays in the FPRS-S200 are the same, and can be swapped for troubleshooting purposes.
 - j. Once repairs are completed, remember to re-install relay CR-8.
 - k. With respect to the High Voltage DC section, the best way to confirm a “bad” power supply, is to obtain a “times 1000” high voltage probe for your voltmeter. Using the Hi-Voltage probe plugged into the red spark plug terminal/boot, a properly operating power supply will indicate 15.00 to 16.00 VDC (15,000 to 16,000 VDC) Defective power supplies will read “0” to 4 KVA.
 - l. **The number one reason for power supply high voltage section failure is operating the Electrostatic Cell beyond one year. (8700 hours)**

BACKFLUSH INDICATOR (AMBER)

Backflushing of the Electrostatic Cell in your unit is unique to the FPRS system. Backflushing the contaminates out of the cell allows for much longer filtration life than with conventional mechanical filters.

The amber “backflush” light is controlled directly by the high voltage power supply orange wire. A normally open relay, inside the high voltage power supply, closes when the power supply senses approximately 500 microamps. As shown on the wiring diagram, once the internal relay closes, the amber backflush light receives power directly. Note that in the FPRS-S200, all five power supplies orange backflush wires are connected to TB-3 terminal 4, which is connected to the backflush light.

A backflush light should always be confirmed by observing the microammeter reading of approximately 500 microamps. Note that the microammeter is connected between system ground and the NEG terminal on the #1 Electrostatic Cell. The orange wired backflush relay inside the power supply also senses 500 microamps, and lights the light, but in a different manner.

Under normal circumstances, when the backflush light comes on, and the microammeter reads 500 microamps, it’s time to backflush all 5 cells, in accordance with the Backflush procedure on page 21 of this manual.

A backflush light on, with a low microammeter reading, most likely indicates a defective power supply relay, sensing circuit, or a defective microammeter. In troubleshooting, if you “jumper” in a spare microammeter, note that the “+” on the meter goes toward the Electrostatic Cell.

The opposite case of a microammeter reading 500, with no accompanying backflush light, should be troubleshot as follows:



1. Secure power to the FPRS.
2. Open the cover and locate the orange wire on terminal 4 of TB-3.
3. Turn power on. Note that you will have to defeat the cover safety switch to continue.
(USE CAUTION)
4. Using a voltmeter, check for 120VAC on the orange wire. If 120VAC is present, replace the amber backflush lamp assy. Note that all of the indicator lights are of the “non-relampable” type, and must be replaced completely.
5. If 120VAC is not present on the orange wire, the power supply is defective.

FLOAT SWITCH INDICATOR (RED)

The float switch prevents an internal FPRS leak from draining the reservoir and is designed to be a “non-resetting” safety fault. The float switch itself is located in a bracket on the drip tray in the bottom of the base cabinet in the right front corner, below the Water Absorber canister. In case of a fluid leak, the float switch will slowly rise on the fluid until the internal magnetic contacts close. Once these contacts close, several things happen at once.

When the contacts of the float switch close, power, which has been sitting on one side of the switch, is allowed to travel to the red float switch light, the coil of CR-6 and contact CR6 – 6. Once CR-6 is energized, the normally closed contacts of CR6 -5 & 1, open, stopping the flow of power to the coil of CR-8. When CR-8 opens, power is removed from the pump and hour meter. The wire coming back down from CR5 – 4, provides power through the (now closed) contacts of CR6 – 4 & 6, keeping the red float switch light on, and the coil of CR-6 closed.

Thus, even though the float switch may only “bump” closed momentarily, the red light and fault will remain “latched” on until an operator intervenes.

If a red “float switch” light is observed, immediately investigate the source of the leak and make any necessary repairs. To reset the fault, turn power off, and then back on.

This circuit can be tested by intentionally closing the float switch, and observing that the light illuminates, and the pump and hour meter stop. Opening the switch will not reset the light, or start the motor.

Troubleshooting this circuit is straightforward. The only components are the float switch itself, relay CR-6, and the associated wiring.

OVERPRESSURE (RED)

The overpressure light circuit in the FPRS-S series units is wired differently than earlier ASL “ABH” or mobile cart units. In the S series units, the overpressure is utilized as an absolute upper pressure limit, and will shut the unit down when activated. Like the float switch fault, the over pressure fault is a latching, non-resetting fault.

As stated elsewhere in this manual, the bypass relief valve on the pump in your FPRS unit is adjusted at the factory so that the pump will be in “full bypass” at approximately 40 psi. If for some reason the bypass relief valve in the pump should fail, system pressures could rise drastically very quickly. The pump is easily capable of pressures exceeding 200 psi. Such a sudden pressure rise, if not checked, could blow the seals in the Electrostatic Cells, water absorber canister, and rupture hoses within the system, causing significant equipment damage and/or personnel injury.

The pressure switch, located on the water absorber canister, is adjusted at the factory to close at approximately three to five psi higher than the pump bypass relief valve, i.e. 43 to 45 psi.

When the contacts of the pressure switch close, power, which has been sitting on the black wire, is allowed to travel through the red pressure switch wire to the red overpressure light, the coil of CR-7 and contact CR7 – 6. Once CR-7 is energized, the normally closed contacts of CR7 -5 & 1, open, stopping the flow of power to the coil of CR-8. When CR-8 opens, power is removed from the pump and hour meter. The wire coming back down from CR5 – 4, provides power through the (now closed) contacts of CR7 – 4 & 6, keeping the overpressure light on, and the coil of CR-7 closed.

Thus, even though the pressure switch may only “bump” closed momentarily, the red light and fault will remain “latched” on until an operator intervenes. Cycle power off – then on.

As designed, when the overpressure circuit is operating properly, it indicates a failure of the pump assembly and/or the pump relief valve. Repairs on the pump should only be undertaken by experienced hydraulic pump repair persons. New/spare pumps can be purchased through ASL.

Troubleshooting this circuit is straightforward. The only components are the pressure switch itself, relay CR-7, and the associated wiring. See the “Removal and Replacement of Components” section, starting on page 37.

MICROAMMETER

The microammeter, located on the front panel between the elapsed time meter and the Absorber pressure gauge, indicates, in micro-amperes, how much current the #1 Electrostatic Cell is pulling from the high voltage power supply. The microammeter shows the general condition of the cell and is a good way to predict impending maintenance actions.

As stated previously in this manual, the microammeter has two readings that are related to two indicator lights on the front panel.

1. At approximately 500 microamperes, the amber “Backflush” light will light, indicating that Electrostatic Cell backflush is required. Shut down the system and backflush the Cells in accordance with the instructions on page 21 of this manual. Note that under normal operating conditions, the microammeter will rise slowly toward 500, giving maintenance adequate warning that backflush time is approaching. Note that the system will continue to operate beyond 500 microamperes, all the way up to 700 microamperes, when the “Low Voltage” light comes on, and the system shuts down. Operation above 500 microamperes for any extended period of time is not recommended, and the cells should be backflushed or replaced as soon as practical.



2. At approximately 700 microamps, the red “Low Voltage” light will come on, and the system will shut down. Unless the reservoir is suddenly flooded with water, or the high voltage power supply fails, you should never see the Low Voltage light come on, other than one or two seconds at initial power-up of the system.

The microammeter on your FPRS system should be checked frequently. When the system is new, and the oil in your reservoir is clean, microamp readings will be low. Normally, the meter will climb very slowly over time, and may take months to reach 500. On other systems, the meter could start at 200 and slowly climb, or even go down over time. The main thing to watch for is erratic movements, rapid climbing, etc. A rapid climb most always indicates water has entered the system, and finding and correcting the source of the water intrusion should be paramount. Once water has entered the Electrostatic Cell, concentrations of 600 ppm and higher, will short it out rapidly. Replacement of the water absorber and Backflushing the Electrostatic Cell (perhaps several times) will restore proper operation.

Changes in microammeter readings will also occur under the following fluid conditions:

1. **HEAT** – Current Increases. Fluid temp. will cause the uA to increase. A rise from 80°F to 110°F can sometimes double the uA. In turn, as fluid temp. decreases, so will the uA.
2. **COOLING** – Current decreases.
3. **WATER** – Water can make the “base current” appear higher than it really is.
4. **VARNISH** – Although the Electrostatic Cell is capable of capturing a lot of varnish before it will effect the operation of the Cell, at some point, as the oil oxidizes, varnish will cause the efficiency of the cell to decrease, and the Cell will need to be replaced.

ELAPSED TIME METER

The elapsed time indicator on the front panel reads in hours and hundredths of hours. The meter is very accurate and reads to 99,999.99 hours.

The meter runs on 120 VAC 60 cycle, single-phase power, which comes from CR8 – 3. This relay contact also supplies power to the pump/motor assembly. Hence, the meter only runs when the pump is receiving power.

In troubleshooting a defective hour meter, with the system running, check for 120VAC power at relay CR8 – 3, if no voltage present, the pump is not running either. If voltage is present, and the pump is running, check for power at the red wire on the back of the meter. If voltage is present (check the white neutral also) replace the meter. If voltage is not present, check the wire running from CR8 –3 to the meter. Note that two wires are installed on CR8-3, black goes to the pump, and red goes to the meter.

If the pump and motor AND the meter are not running (no other abnormal system indications) check for 120VAC at the coil of CR8 – 8. If voltage is present, there should be power on CR8 – 3. If no voltage on CR8 –3, replace the relay. If no voltage present on the coil of CR8 – 8, trace backwards to CR7 – 1, CR6 – 1, etc. The coil of CR-8 can only receive power if all 5 High Voltage Power Supplies are working, and there are no faults from the pressure switch, or float switch. Refer to the wiring diagram on page 29 of this manual.

REMOTE ALARM CIRCUIT

The remote alarm circuit consists of two sets of “dry” contacts in relays CR-1 and CR-8. CR8 – 6 & 4, are closed during normal operation, as are CR8 – 4 & 6. Two wires lead out to a two pin male “spade” connector, which accepts .250 inch female spade terminals. This connector is located on the right side of the cabinet, just below the power cord.

During normal operation, these two pins will have continuity between them, and are for customer interface with an outside indication or warning system such as a PLC. When attaching an external system, do not exceed 24 VDC.

Thus, any problem that stops the power supply (CR-1) or the Pump (CR-8) will cause an open between the two remote alarm contacts.

PUMP/MOTOR ASSEMBLY

The pump and motor assembly used in your FPRS is designed for continuous duty, and will give many years of trouble free service. For your convenience, the pump manufacturers service manual is located in the last section of this manual, starting on page 44. The pump and motor consists of three basic parts, which are all easily field replaceable.

Coupling the pump to the motor is a lovejoy-type coupler. Replacement of the pump or coupler is straightforward, and should present no problem for maintenance. See the following section for removal and replacement of the pump, along with required adjustments.

REMOVAL AND REPLACEMENT OF COMPONENTS

Front Panel Indicator Lights

These lights are the “non-relampable” type, and are a “snap-fit” into the top cover. Remove the two .186 spade connectors, and compress the tangs on the sides of the lamp using thumb and forefinger. Push the lamp from the back out through the front cover. Replacement lights are available from ASL.

Microammeter

The microammeter is a special Simpson DC Microamperes design. Using a meter not intended for your FPRS is not recommended and could result in damage to the equipment. To replace the meter, remove the two 5/16” nuts which secure the green wires to the back of the meter. Using a ¼” nut driver, remove the four nuts and lockwashers securing the meter to the cover. Push the meter out from the back to the front. Install the new meter (make sure it’s right side up) and secure the four ¼” nuts/lockwashers, taking care not to over tighten. Re-install the wiring to the two posts, making sure that the wire on the “+” terminal goes toward the #1 Electrostatic Cell.

Hour Meter

The hourmeter is held in place with two 6-32 screws and locknuts. Remove the two spade wiring terminals from the meter by pulling straight up. Remove and retain the attaching screws and nuts. Remove the meter by pushing it out from back to front. Install the new meter (make sure it’s right side up) using the retained screws and nuts, and re-attach the spade terminals.

Hi Voltage Power Supply

Secure power to the FPRS before replacing the power supply.

1. Using an insulated screwdriver, short across the POS and NEG terminals of the Electrostatic Cell to dissipate any static electricity.
2. Using one hand, remove the POS terminal from the Electrostatic Cell.
3. Cut all ty-wraps securing the POS and NEG leads from the cell to the power supply.
4. Remove the wiring trough cover above the power supplies.
5. Locate the two-pin Molex connector for the Yellow and Orange wires coming from the power supply, and disconnect it by pulling the two halves apart.
6. Pull the three spade connectors (Power, Neutral and Ground) from the power supply.



7. Remove the two 6-32 nuts and washers from the studs, and remove the power supply from the unit. Note that the red high voltage lead and spark plug terminal/boot remain attached to the power supply.
8. Install the new power supply in the reverse order. Note that replacement power supplies have a relatively long Positive lead with the boot and terminal installed at the factory.
9. Plug in the three spade connectors to the power supply, observing wire color codes and power supply connector labels. Red wire to HOT +, Green wire to GND, and white wire to HOT -. Connect the two pin yellow/orange connector to the harness, and re-install the wire trough cover.

Electrostatic Cell

See page 22 in this manual.

Water Absorber Element

See page 23 in this manual.

Pump/Motor COMBINATION

Replacement of the pump and motor is straightforward. The pump/motor is secured to studs in the back of the cabinet with four ¼-20 locknuts and flat washers. Secure power to the unit before any servicing.

1. Start by removing the motor wiring box cover and disconnecting the wire nuts tying the SO cord to the motor leads. The green ground wire is secured with a green screw to the motor inside the motor wiring box. Pull the SO cord out of the motor wiring box and plastic “Heyco” connector. Note that wire connections and numbers are located on the motor nameplate, as well as page 43 of this manual.
2. The hose connections to the motor are of the “push-lock” type, and will have to be cut. Slit the inlet and outlet hoses the minimum amount necessary to allow removal of the hoses from the push-lock fittings. Trim the hose ends square for re-installation. Excessive slitting and /or trimming will render the hoses too short, and they will have to be replaced. There is enough excess hose length to remove and replace the pump at least once or twice.
3. With the wiring and hoses disconnected, remove the four ¼-20 nuts and washers, and remove the pump/motor assembly from the cabinet.
4. With both the old and new pumps/motors on the workbench, transfer the inlet/outlet hose fittings and the black “Heyco” wiring fitting to the new pump/motor. Take care to align the fittings the same way they were. Use a suitable thread sealer on all pipe threads.
5. Install the pump/motor into the cabinet by reversing the above instructions. A drop of lubricant on the push-lock fittings will ease installation of the hoses.
6. Secure all wiring and hoses and proceed to “**PUMP and PRESSURE SWITCH ADJUSTMENTS**” on page 40.

Replacement of PUMP only

If you have determined that only the pump needs to be replaced, the motor and it’s electrical connections can remain attached to the cabinet.

1. Remove the pump inlet and outlet hoses. The fittings are of the “push-lock” type, and the hoses must be cut. Slit the inlet and outlet hoses the minimum amount necessary to allow removal of the hoses from the push-lock fittings. Trim the hose ends square for re-installation. Excessive slitting and /or trimming will render the hoses too short,



- and they will have to be replaced. There is enough excess hose length to remove and replace the pump at least once or twice.
2. Remove the four bolts securing the pump to the motor.
 3. Using a suitable Allen wrench, loosen the setscrews on the Lovejoy coupler.
 4. Separate the pump from the motor by pulling straight up on the pump body while rotating the pump.
 5. With the old and new pumps on the workbench, transfer the inlet and outlet fittings to the new pump. Take care to align the fittings as they were. Use a suitable thread sealer on all pipe threads.
 6. Assemble pump to motor in reverse order, remembering to align and tighten the Lovejoy coupler set screws.
 7. Re-install inlet and outlet hoses. A drop of lubricant on the push-lock fittings will ease installation of the hoses.
 8. Proceed to “PUMP and PRESSURE SWITCH ADJUSTMENTS” on page 40.

Replacement of MOTOR only

If you have determined that only the motor needs to be replaced, the pump and its attached hoses can remain in the cabinet.

1. Start by removing the motor wiring box cover and disconnecting the wire nuts tying the SO cord to the motor leads. The green ground wire is secured with a green screw to the motor inside the motor wiring box. Pull the SO cord out of the motor wiring box and plastic “Heyco” connector. Note that wire connections and numbers are located on the motor nameplate, as well as page 43 of this manual.
2. Remove the four bolts securing the pump to the motor.
3. Loosen the setscrews securing the Lovejoy coupler to the pump and motor shaft.
4. Separate the pump from the motor by pulling straight up on the pump body while rotating the pump.
5. With the pump and motor separated and the wiring removed, remove the four ¼-20 nuts and flat washers securing the motor to the cabinet studs and lift the motor out of the cabinet.
6. Transfer the black “Heyco” wiring fitting and locknut to the wiring box of the new motor.
7. Install and align the Lovejoy coupler to the motor shaft.
8. Install the new motor onto the cabinet studs and secure with four ¼-20 locknuts and flat washers.
9. Using a twisting motion, install the pump onto the motor, taking care to align the Lovejoy coupler. Secure the coupler set screws.
10. Re-install the four bolts thru the pump to the motor.
11. Re-install the SO cord through the “Heyco” fitting and re-connect wiring in accordance with the diagram on page 43 of this manual.
12. Tie up any loose wiring and return the unit to service. Note that pump adjustments should not be required when replacing the motor only.

Pressure Switch Replacement

Replacement of the pressure switch will normally never be required, due to the fact that correct operation of the switch will occur only after failure of the pump by-pass and system pressure has exceeded 43 to 45 psi. There are other instances that could cause illumination of the overpressure light, such as “back-feed” pressure from the outlet side, which could be caused by incorrect installation. Adjustment of this switch, however, is critical and will be required following replacement of the pump or the pressure switch. Replacement of this switch is straightforward, and only requires un-screwing it from the water absorber canister, and connecting the black and red wires. The green wire is not used, and should be capped.

Following pressure switch replacement, proceed to the “**PUMP and PRESSURE SWITCH ADJUSTMENTS**” below.

PUMP and PRESSURE SWITCH ADJUSTMENTS

The following procedure should be followed after replacement of the pump and/or pressure switch. Note that these adjustments are **CRITICAL** to proper system operation and should be read and understood before continuing.



WARNING – This procedure will involve temporarily raising system pressures to higher than normal levels. Care should be taken to avoid gross over-pressurization of the system. This procedure will also require that the cover safety switch be defeated. Maintenance personnel are cautioned to take extra care when operating the system with the covers removed. Refer to the pump vendor service manual, starting on page 44 of this manual.

1. Start system and wait until output flow is observed.
2. Remove the acorn nut on the pump relief valve. (1-1/16” wrench size)
3. Insert a screwdriver into the slot of the adjusting screw and hold it steady.
4. Loosen the 1-1/8” locking nut with a wrench by turning counterclockwise.
5. Temporarily attach a ball valve to the “Outlet” port on the right side of the system cabinet. Slowly close the ball valve until the system pressure is at 50 psi. If the pressure fails to reach this level with the ball valve closed, turn the adjusting screw inward (clockwise) until the desired pressure is reached. (Adjusting clockwise raises the pressure setting).
6. If the pressure reaches 50 psi before the throttling valve is completely closed, turn the adjusting screw outward (counterclockwise) until 50 psi is reached. (Adjusting counterclockwise lowers the pressure setting).
7. The pressure switch may close during the above adjustment, shutting the system down with an “Over Pressure” fault. If this happens, remove the 1/8 inch Allen lock screw from the pressure switch and set aside. The pressure switch adjustment is also a 1/8 inch Allen, and can be adjusted after removing the lock screw. Turn the pressure switch adjustment clockwise to raise the switch closing point above the pump by pass setting.
8. Once the pump by-pass is set at 50 psi. with the throttling valve closed, open the throttling valve for a few minutes to let the system flow. Operation with the pump in full bypass for long periods will cause excessive heat buildup and could cause damage to the pump.
9. Slowly close the throttling valve until the pressure gauge reads approximately 43 to 45 psi. Adjust the pressure switch slowly counterclockwise until the system shuts down
10. Open the throttling valve and re-start the system.



11. Slowly close the throttling valve while observing the pressure gauge until the system shuts down. The system should shut down with the “Over Pressure” fault at approximately 43 to 45 psi. Repeat the pressure switch adjustment, until the switch closes at approximately 43 to 45 psi.
12. Open the throttling valve and re-start the system. Slowly close the throttling valve until the pressure gauge reads **40 psi**. Turn the pump by-pass adjusting screw counterclockwise until the pressure just begins to drop. Tighten the nut to lock the setting in place.
13. Open the throttling valve for a few minutes, and then slowly close it fully. Observe that the system pressure stays at 40 psi. with the throttling valve fully closed. Re-adjust if necessary.
14. Once all adjustments are complete, open the throttling valve completely and replace the acorn nut on the pump by-pass valve and the 1/8 inch Allen lock screw in the pressure switch.

SCHEDULED MAINTENANCE TASKS

The following is a recommended scheduled maintenance plan, which is intended to provide maximum performance from your FPRS unit.

DAILY

1. Check that green “Power” lamp is illuminated.
2. Check that pump/motor and hour meter are running.
3. Check system pressure gauge below 35 psi.
4. Check Microammeter below 500 microamps.

WEEKLY

1. Leave the “Power switch” in the “ON” position, open the top cover and observe that the unit shuts down.
2. Check for any internal leaks.
3. Check for loose relays, wiring and connections for security.
4. Close the top cover and observe that the unit re-starts.
5. Perform the daily checks after the unit has re-started.

MONTHLY

In addition to the weekly checks above, perform the following additional checks:

1. Using a soft cloth, wipe down the exterior surfaces of the cabinet. The static electricity forces at work inside your FPRS unit will attract dirt and dust from the air around the unit. Pay particular attention to the cooling vents on the bottom and back of the cabinet.
2. Inspect the inlet and outlet fluid hoses for signs of leaks or deterioration.
3. Inspect the power cord for evidence of wear or fraying.



YEARLY

In addition to the monthly checks above, perform the following additional maintenance actions and checks:

1. Replace the Electrostatic Cells. Even though the system appears to be operating properly, the Electrostatic Cells should be replaced on an annual basis due to internal wear, which can cause arcing and deterioration.
2. Replace Water Absorber element. This throw away element, although designed primarily to entrap free and emulsified water, will also trap larger particulate, and should be replaced at least once each year.

FPRS S-200 SERIES CABINET FLUID FLOW DIAGRAM

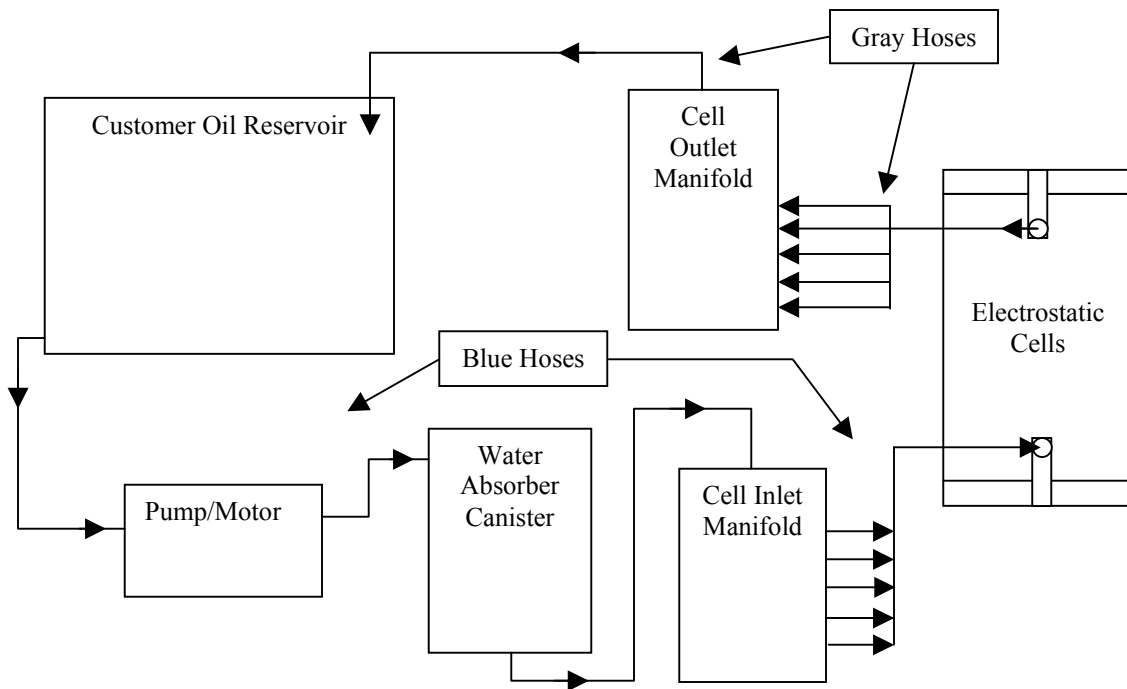



FPRS-S-200

ASL Technologies, LLC
10525 W US Hwy 30, Bldg 3D Wanatah, In. 46390
Phone 219.733.2777 or Toll Free 888-333.2990
Facsimile 219.733.2779 or e-mail custsvc@aslfilter.com

www.aslfilter.com

Motor Wiring Data

(Motor is ASL Factory wired Lo Volt CCW Rotation)

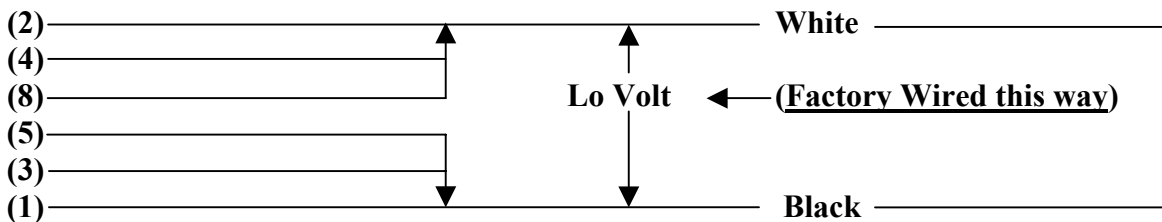

Do not reverse rotation!

The following pages contain the Installation and Service Instructions for the Viking Series SG-04, SG-05, and SG-07 Spur Gear pumps. The model used in the ASL-FPRS-S200 is SG-0570. This manual is reprinted with permission from Viking Pump.



TECHNICAL SERVICE MANUAL

SECTION	TSM 340
PAGE	1
ISSUE	C

INSTALLATION, START UP, TROUBLESHOOTING,
PREVENTIVE MAINTENANCE, DO'S & DON'TS
SERIES SG-04, SG-05 & SG-07 SPUR GEAR PUMPS

CONTENTS

Installation	1
Mounting	2
Start Up	3
Troubleshooting	6
Miscellaneous	8
Do's and Don'ts	9
Warranty	10

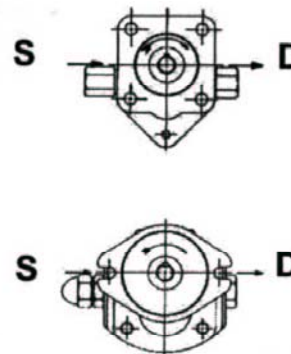

FIGURE 1

INSTALLATION

General

The following items must be considered prior to pump installation:

1. Location - locate the pump as close as possible to the liquid supply. If possible locate the pump below the liquid supply. Viking pumps are self-priming; but the better the suction conditions, the better the pump will perform.
2. Accessibility – the pump must be accessible for inspection, maintenance and repair.
3. Suction/Discharge - SG Series pumps are designed for clockwise rotation as standard (viewed from end of shaft). Refer to Figure 1.
4. Pressure Relief Valve - the SG Series is a positive displacement pump and requires some form of over pressure protection. Without pressure protection, if the discharge line is blocked or becomes closed, pressure will build up until the motor stalls, drive equipment fails, a pump part breaks, or the piping and/or other equipment in the system bursts. To prevent the possibility of any one or more of the above from occurring, the use of a pressure relief valve is recommended.
5. Storage - drain the pump and apply a light coat of non-detergent SAE 30 weight oil to all internal pump parts. Apply grease to the pump shaft extension. Viking suggests rotating the pump shaft by hand one complete revolution every 30 days to circulate the oil.



MOUNTING

1. Surfaces to which the pump mounts must be clean and flat.
2. Use SAE Grade 5 or better capscrews to mount pump.
3. The 4 mounting capscrews for the SG-04 and SG-05 pumps must have a minimum of ½ inch thread engagement, and must be torqued evenly to 12-15 ft-lbs.
4. The 2 mounting capscrews for the SG-07 pumps must have a minimum of ½ inch thread engagement, and be evenly torqued to 50-55 ft-lbs.
5. Standard SG Series pumps are designed to be used with jaw type couplings that do not induce axial thrust on the pump shaft. If an improper type of coupling is used, internal damage may result.
6. Do not strike or press the pump drive coupling to install. Internal pump damage will result. If the coupling does not slide onto the shaft, inspect the coupling, shaft and key for nicks or burrs and remove.
7. If the pump is to be belt or gear driven, the overhung load option must be specified.
8. Once the pump has been mounted and the coupling installed, it is recommended to put lube oil into the suction port and turn the pump by hand to make sure it turns freely.

Alignment

Check alignment after mounting.

1. If the unit has a flexible coupling, remove any coupling guards or covers and check alignment of coupling halves. A straight edge (piece of key stock will work) across the coupling must rest evenly on both rims at the top, bottom and sides. See Figure 3.
2. Make a final check on alignment after the piping is hooked up.

USE STRAIGHT EDGE. THESE SURFACES MUST BE PARALLEL

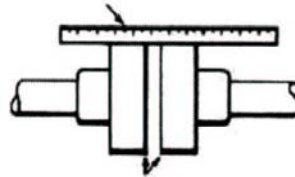

CHECK WIDTH BETWEEN THESE SURFACES WITH INSIDE CALIPERS OR FEELER GAUGE TO BE CERTAIN THE FACES ARE EQUAL DISTANCE APART AND PARALLEL.

FIGURE 3

Piping/Hose

The cause of many pumping problems can be traced to the suction piping. It should always be as large in diameter and as short in length as possible.

Before starting the layout and installation of your piping system, consider the following points:

1. Never use piping smaller than the pump port connections. Piping larger in diameter than the port connection is sometimes required to reduce friction losses.



2. Be sure the inside of the pipe is clean before installing.
3. When approaching an obstacle to the suction line, go around instead of over it. Going over an obstacle can create an air pocket. Where practical, slope the piping so no air or liquid pockets will be formed. Air pockets in the suction line make it hard for the pump to prime.
4. A strainer on the suction side of the pump should always be considered in any pumping system. The strainer will keep foreign matter from entering the pump. The strainer mesh or perforation size should be large enough so that it does not cause excessive pressure drop, but fine enough to protect the pump. Use of a strainer is particularly important at start up to help clean the system of weld beads, pipe scale and other foreign objects.
5. A pressure relief valve is required in the discharge line. See Pressure Relief Valves, General page 1 item 4.
6. The pump must not be used to support the piping. Hangers, supports, stands, etc. must carry the weight of the pipes.
7. When fastening piping to the pump do not impose any strain on the pump casing. "Springing" or "drawing" the piping up to the pump will cause distortion, possible misalignment and probable rapid wear of the pump. Do not use the pump to correct errors in piping layout or assembly.
8. All joints in the piping system must be tight; liquid thread sealant will help assure leak-free threaded joints. Be careful not to over tighten the fittings to the pump, as this can damage the pump. Leaks in the suction line can permit air to be drawn in, and will cause a noisy pump and reduction in capacity.
9. Drive alignment must be checked after piping is hooked up.
10. Provide a pressure relief device in any part of a pump and piping system that can be valved off and, thus, completely isolated. A rise in temperature will cause a liquid to expand. If there is no provision for pressure relief in the closed off section, there is a chance that the pump or piping will rupture.

Danger !

Before starting pump, be sure all drive equipment guards are in place.

Failure to properly mount guards may result in serious injury or death.

START UP

Before pushing "start" button, check the following:

1. Are vacuum and pressure gauges (liquid filled) mounted on or near the pump? Gauges are the quickest and most accurate way of finding out what is happening in the pump.
2. Is the pump is correctly aligned with the drive equipment?
3. Make sure there is no pipe strain on the pump ports.
4. Rotate the pump shaft by hand to be sure it turns freely.



FPRS-S-200

ASL Technologies, LLC

10525 W US Hwy 30, Bldg 3D Wanatah, In. 46390

Phone 219.733.2777 or Toll Free 888-333.2990

Facsimile 219.733.2779 or e-mail custsvc@aslfilter.com

www.aslfilter.com

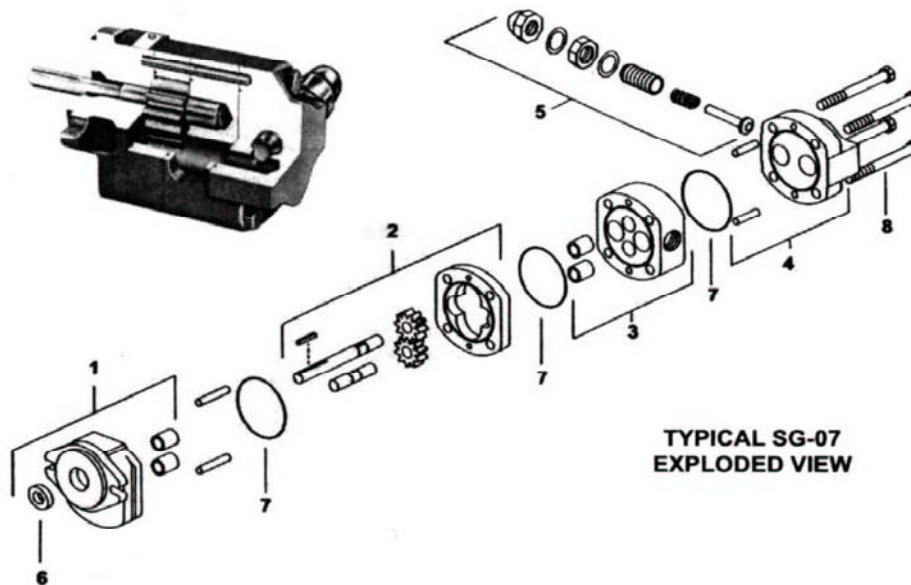
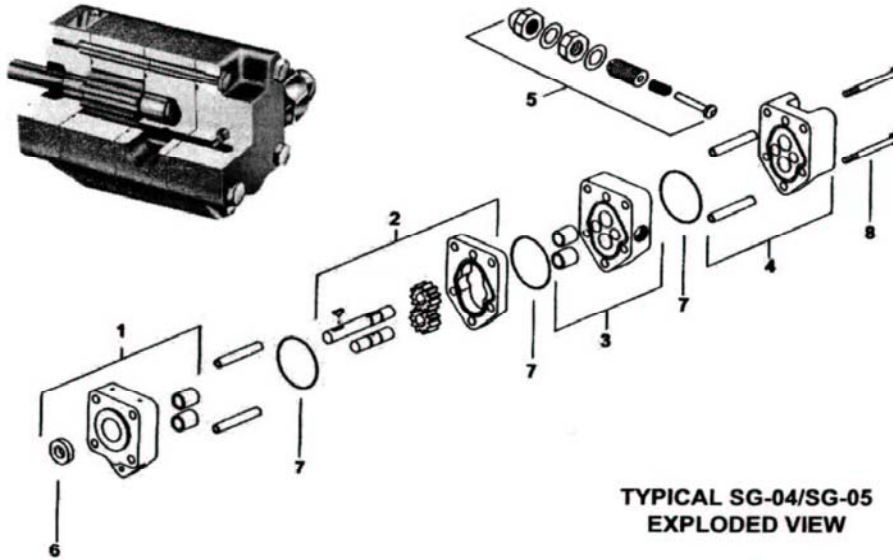

ITEM	DESCRIPTION	ITEM	DESCRIPTION
1.	Bracket, lipseal & bearing section	5.	Relief valve kit
2.	Match ground casing & (2) gears, driver & driven shafts	6.	Lipseal
3.	Separation plate & bearing assy.	7.	O-ring
4.	Head and alignment sleeve assy.	8.	Assembly capscrews



5. Before connecting to the motor, jog it to be sure it is running in the correct direction. Refer to "General" on page 1.
6. Is the pressure relief valve installed properly?
7. Make sure suction piping is properly connected and sealed, and valves are open.
8. Make sure the discharge piping is properly connected and sealed, valves are open, and there is a place for the liquid to go.
9. Make sure all guards are in place.
10. The above checklist is a general guideline to be used prior to starting the pump. Since Viking Pump cannot foresee every application for our product and possible system design, the final responsibility is with the user. The pump must be utilized within the catalog specifications and the pump system must be designed to provide safe working conditions.

The "start" button may now be pushed.

The pump should begin to deliver liquid within 15 seconds! If not, push the stop button. Do not run the pump without liquid flow longer than 30 seconds or the pump may be ruined.

Review Startup steps 1 through 10. Consider what the suction and discharge gauges may indicate. If everything appears in order, re-prime pump. Refer to Mounting page 2, item 8.

Push the "start" button. If nothing is flowing within 30 seconds, stop the pump. The pump is not a compressor, it will not build up much air pressure. It may be necessary to vent discharge line until liquid begins to flow.

If pump still does not deliver, consider one or more of the following:

1. The suction line has air leaks.
2. The end of the suction pipe is not submerged deeply enough in the liquid.
3. The suction lift is too great or the suction piping is too small.
4. Liquid is vaporizing in the suction line before it gets to the pump.

If after consideration of these points, the pump still does not deliver liquid, review all points given under START UP and read through the TROUBLESHOOTING guide and try again. If pump still will not deliver liquid, contact your Viking Pump supplier.



TROUBLESHOOTING

A Viking pump that is properly installed and maintained will give long satisfactory performance.

If trouble does develop, one of the first steps toward finding the difficulty is to install a vacuum gauge in the suction line and a pressure gauge in the discharge line. Readings on these gauges often give a clue on where to start looking for trouble.

DANGER !

Before opening any Viking pump liquid chamber (pumping chamber, reservoir, relief valve adjusting cap fitting etc.) be sure:

1. That any pressure in chamber has been completely vented through the suction or discharge lines or other appropriate openings or connections.
2. That the driving means (motor, turbine, engine, etc.) has been "locked out" or made non-operational so that it cannot be started while work is being done on the pump.
3. That you know what liquid the pump has been handling and the precautions necessary to safely handle the liquid. Obtain a material safety data sheet (MSDS) for the liquid to be sure these precautions are understood.

Failure to follow the above listed precautionary measures may result in serious injury or death.

Vacuum Gauge - Suction Port

High vacuum reading would indicate:

1. The suction line is blocked, valve closed, a strainer is plugged or a pinched suction line.
2. The suction line is too small.
3. The liquid is too viscous to flow through the piping.
4. The lift required is too high.

Low reading would indicate:

1. There may be an air leak in the suction line.
2. The end of the pipe is not in the liquid.
3. The pump is worn.
4. The pump is dry and should be primed.

Fluttery, jumping or erratic reading would indicate:

1. The liquid is vaporizing.
2. Liquid is coming in to the pump in slugs, possibly an air leak or insufficient liquid above the end of the suction pipe.
3. Vibration from cavitation, misalignment, or damaged parts.

Pressure Gauge - Discharge Port

High reading would indicate:

1. High viscosity and small diameter and/or lengthy discharge line.
2. The strainer or filter is plugged.
3. The pressure relief valve is set too high.
4. Valve in the discharge line partially closed.
5. Line may be partially plugged from build up; on the inside of the pump, solidified product or foreign object.
6. Liquid in the pipe is not up to temperature.

Low reading would indicate:

1. Pressure relief valve may be set too low.
2. Pressure relief valve poppet is not seating properly.
3. Pump mounting capscrews not torqued to specifications (SG-04 and SG-05 Series 12-15 ft.-lbs.).
4. Pump assembly bolts not torqued to specifications (SG-07 Series 50-55 ft.-lbs.).
5. The bypass around the pump is partially open.
6. Pump is damaged or worn.
7. The pump has too much internal clearance.

Fluttery, jumping or erratic reading would indicate:

1. Cavitation.
2. Liquid is coming to the pump in slugs.
3. Air leak in the suction line.
4. Vibrating from misalignment or mechanical problems.



Miscellaneous

Pump does not pump:

1. The pump has lost its prime from air leak or low level in tank.
2. The suction lift is too high.
3. Rotating in the wrong direction.
4. The motor does not come up to speed.
5. The strainer is clogged.
6. The bypass valve is open, pressure relief valve set too low, or pressure relief valve poppet stuck open.
7. The pump is worn out.
8. Any changes in liquid, system or operation that would help explain the trouble, e.g. new liquid, additional lines or process changes.

Pump starts, then loses its prime:

1. The supply tank is empty.
2. The liquid is vaporizing in the suction line.
3. There is an air leak or air pockets in the suction line.
4. The pump is worn out.

Pump is noisy:

1. The pump is cavitating (liquid vaporizing in suction line) or being starved (heavy liquid cannot get to pump fast enough). Increase the suction pipe size and/or reduce the length, or decrease the pump speed. If the pump is above the liquid, raise the liquid level closer to the center line of the inlet port. If the liquid is above the pump, increase the head of the liquid.
2. Check alignment.
3. Anchor the base or piping to eliminate vibration.

Pump not delivering up to capacity:

1. The pump is starving or cavitating – see **Pump is noisy**, item 1.
2. The strainer partially clogged.
3. Air leak somewhere in the suction line.
4. Running too slow. Is the motor the correct speed and wired up correctly?
5. Pressure relief valve is set too low, stuck open or has damaged poppet seat.
6. The bypass line around the pump partially opened.
7. The pump is worn out.

Pump takes too much power (stalls motor):

1. Liquid is more viscous than the unit is sized to handle.
2. The system pressure relief valve set too high.
3. The pump is misaligned.

DO'S AND DON'TS

Do's and Don'ts for installation, operation and maintenance of Viking pumps to promote safe, long, trouble free operation.

Installation:

1. DO install the pump as close to supply tank as possible.
2. DO leave working space around the pumping unit.
3. DO use large diameter pipe with short and straight runs.
4. DO install a strainer in the suction line.
5. DO a double check of alignment after unit is mounted and piping is hooked up.
6. DO provide pressure relief valve for discharge side of pump.
7. DO check for proper rotation.
9. DO use piping, hose and fittings rated for maximum system pressure.
10. DO check to make sure all guards are in place.

Operation

1. DON'T run the pump at speeds faster than 3600 RPM.
2. DON'T allow the pump to develop pressure higher than those shown in catalog for your pump.
3. DON'T operate pumps at temperatures above or below limits shown in catalog for your pump.
4. DON'T operate unit without all guards in place.
5. DON'T operate pump without a pressure relief valve in discharge piping; be sure the valve is mounted and set correctly.
6. DON'T operate the pump with all the liquid bypassing through the internal pressure relief valve or with out any flow of liquid going through the pump for more than 30 seconds. Operation under either of these conditions may result in heat build up and damage to the pump.
7. DON'T work on the pump unless driver has been "locked out" so it cannot be started while work is being done on the pump.

Maintenance:

1. DO record pump model number and serial number and file for further use.
2. DO have spare parts, pump or stand by units available, particularly if pump is essential part of key operation process.
3. DO obtain, read and keep all maintenance instructions furnished with pump.
4. DO make sure any pump that has residual system pressure in it or that has handled high vapor pressure liquids, has been vented through the suction or discharge lines or other openings provided for this purpose.



5. DO make sure that if the pump is still hooked to the driver while maintenance is being performed that the driver has been "locked out" so that it cannot be inadvertently started while work is being done on the pump.
6. DO make sure any pump that has handled a corrosive, flammable, hot or toxic liquid has been drained, flushed, vented and/or cooled before it is disassembled.

VIKING PUMP **IDEX**
IDEX CORPORATION

WARRANTY

Viking warrants all products manufactured by it to be free from defects in workmanship or material for a period of one (1) year from date of startup, provided that in no event shall this warranty extend more than eighteen (18) months from the date of shipment from Viking. If, during said warranty period, any products sold by Viking prove to be defective in workmanship or material under normal use and service, and if such products are returned to Viking's factory at Cedar Falls, Iowa, transportation charges prepaid, and if the products are found by Viking to be defective in workmanship or material, they will be replaced or repaired free of charge, FOB. Cedar Falls, Iowa.

Viking assumes no liability for consequential damages of any kind and the purchaser by acceptance of delivery assumes all liability for the consequences of the use or misuse of Viking products by the purchaser, his employees or others. Viking will assume no field expense for service or parts unless authorized by it in advance.

Equipment and accessories purchased by Viking from outside sources which are incorporated into any Viking product are warranted only to the extent of and by the original manufacturer's warranty or guarantee, if any.

THIS IS VIKING'S SOLE WARRANTY AND IS IN LIEU OF ALL OTHER WARRANTIES, EXPRESSED OR IMPLIED, WHICH ARE HEREBY EXCLUDED, INCLUDING IN PARTICULAR ALL WARRANTIES OF MERCHANTABILITY OR FITNESS FOR A PARTICULAR PURPOSE. No officer or employee of IDEX Corporation or Viking Pump, Inc.. is authorized to alter this warranty.

END OF SERVICE MANUAL