

Automate and secure your entrance in style

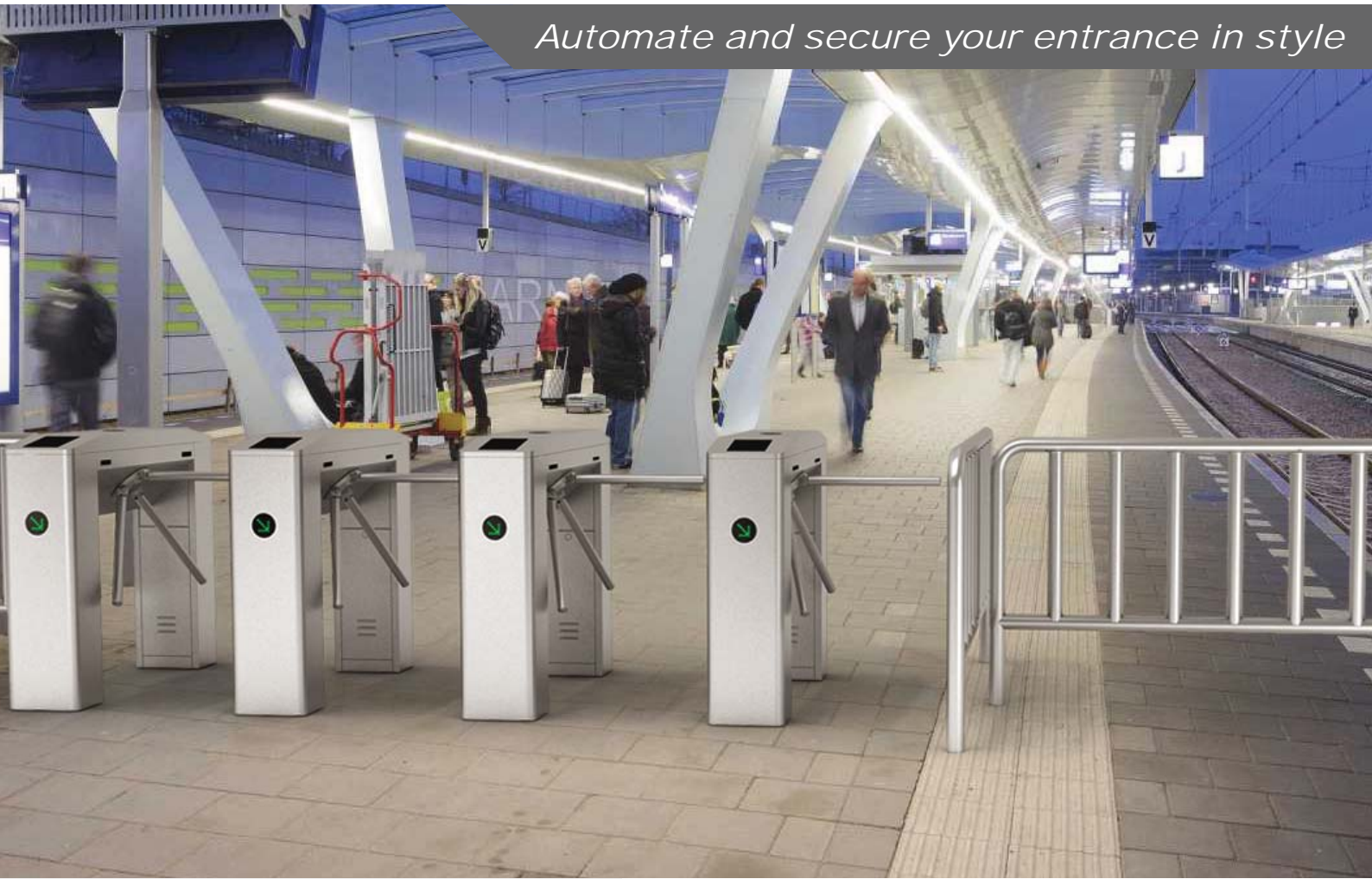

Fully automated motorized Tripod turnstile.

Model : TTS480

TTS480 is a fully automatic tripod turnstile that is design for heavy traffic of public mass transportation such as bus or train station. TTS480 is using high duty cycle servo motor and robust mechanical gear system to cater continuous non-stop pedestrian traffic during peak hours.

TTS480 is equipped with more advance control system to accomodate rough usage and force pass through attempts.

TTS480 is an innovative pedestrian control technology that designed to achieve best balance of quality, performance and affordability.

TTS480 is ideal indoor solution for game park, bus station, train station, stadium or any site with high traffic flow.



Premium
automation



TECHNICAL SPECIFICATION:

Description	Parameters
Temperature	15° to 60C
Operating voltage	DC 24V
Power supply input	220V ± 10% AC, 50 / 60Hz
Current consumption	5 A
Humidity	0 to 95%
Optimal traffic rate	20 to 30 people per min
Motor type	Brushless DC servo motor

DIMENSION:

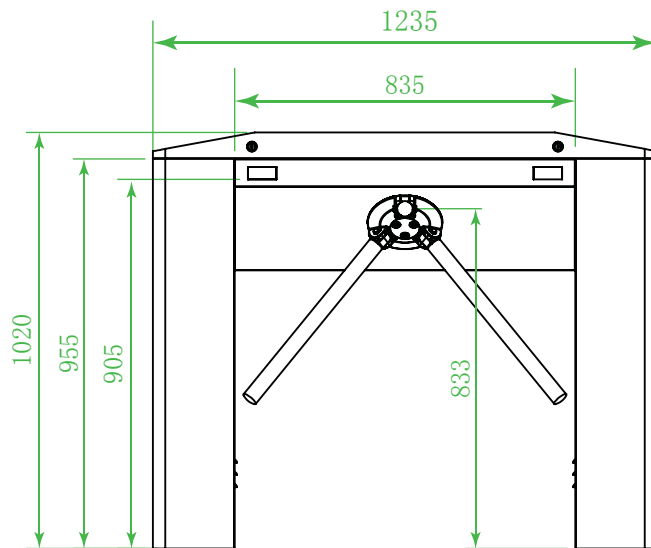

ORDERING INFO:

Model No	Description
TTS480	Automatic motorized tripod turnstile

ACCESSORIES:



Safety beam



Push Button

Authorized dealer

Feature

1 MINIMUM MAINTENANCE

Uses brushless DC motor eliminate the need of changing carbon brush thus reducing maintenance work. Key internal parts is treated with anti-rust and anti-septic to ensure long term reliability.

2 HEAVY DUTY

All internal gear and mechanism is extra harden to cater for application with high traffic flow. Arm support buffer rotation to protect motor from being damaged during vandalism attempt to turn the arm by force.

3 EASY INTEGRATION

Dry contact output feedback signal is available to indicate completion of rotation of single user. Turnstile can be manually triggered to drop arm or free rotation. Separate dry contact input is available to trigger turnstile to open from LEFT or RIGHT. All these input and output interface make it easy to integrate with external system such as ticketing or access control.

4 ANTI TAILGATING

Arm will automatic lock back after each passes to avoid second person following from back.

5 EMERGENCY RECOVERY

During power failure, arm will drop down automatically to allow free pass through. In the event of emergency such as fire alarm, arm can be manually triggered for free turning permanently to allow fast evacuation.

Premium
automation

" Entrance is the first level of protection in building security. MAG offer complete gate automation system to secure your entrance.... "

