

«CORDON-M»2

RADAR VIDEO RECORDING SYSTEM

PREPARING FOR PRODUCTION



The new «CORDON-M»2 radar system is designed for automatic traffic enforcement and data transfer to the Police back-office.

- Cost-effective solution for controlling narrow roads with 2 lanes of traffic
- Low power consumption
- Various installation and power supply options available
- Ability to use independent power source
- High resolution video camera
- License plate recognition system based on neural networks

BASIC FUNCTIONS AND FEATURES

- The system can measure speeds, positions and record images for all vehicles on two lanes of two-way traffic.
- Automatic detection of vehicles driving on the wrong side of the road, as well as detection of violating traffic on roadside or reserved bus lane.
- Systems for controlling red light violations and road or railroad crossings can be built based on «CORDON-M»2 sensors.
- Specific speed limits for each lane and for the various categories of vehicle (cargo truck, passenger car) can be set.
- Automatic License Plate Recognition for Europe and CIS license plates. System can be trained to recognize new patterns of license plates in short time.
- Ability to check the recognized license plates through various databases (vehicle owners, stolen and wanted vehicles, etc.) on site.
- Automatic saving of violation data on internal storage.
- Ability to transmit the recorded violation data to back office via wire or wireless communication channels.
- Ability to export the recorded violation data from sensor to laptop in patrol vehicle via backup communication channel (Wi-Fi).
- On-board GPS/GLONASS navigation unit provides the geographical coordinates and precise timing for the violation record.
- Automatic time synchronization with satellite navigation system and/or with time server.
- Nighttime operation using the embedded and external IR spotlights.
- Real-time high resolution surveillance of enforcement zone.
- Ability to stream the video in real time using RTSP protocol.
- Automatic recording and storing video clips of road situation

to the archive (up to 24 hours of video), ability to search through archive for specified time period.

- Can be integrated into traffic management system.
- Gathering of traffic intensity statistics.
- Protection of embedded software and output data from unauthorized change.
- Logging of all system events and user actions.
- Small weight and dimensions of the sensor, low power consumption.
- Various installation and power supply options.
- Ability to use independent power source greatly enhances the system installation options.

PHOTO RADAR SENSOR DESIGN

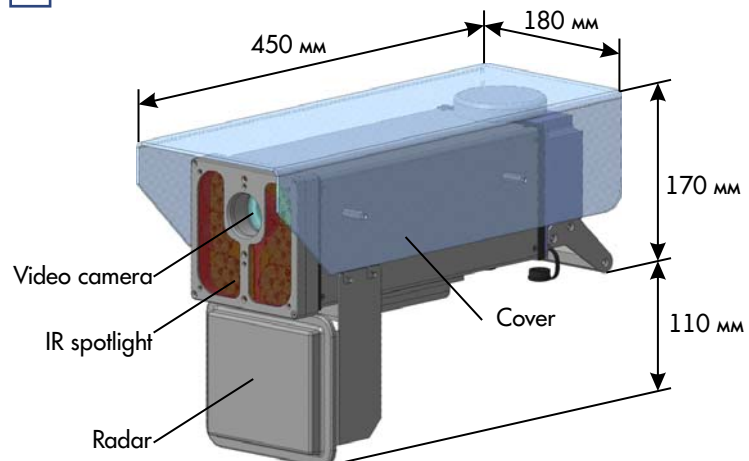

SIMICON
WWW.SIMICON.COM

OPERATION PRINCIPLE

The system automatically measures speeds of all vehicles in enforcement zone and records a pair of images for every captured vehicle: wide-angle image of all targets within the camera field of view (with the captured vehicle clearly identified), and a close-up image of the captured vehicle with clearly visible license plate.

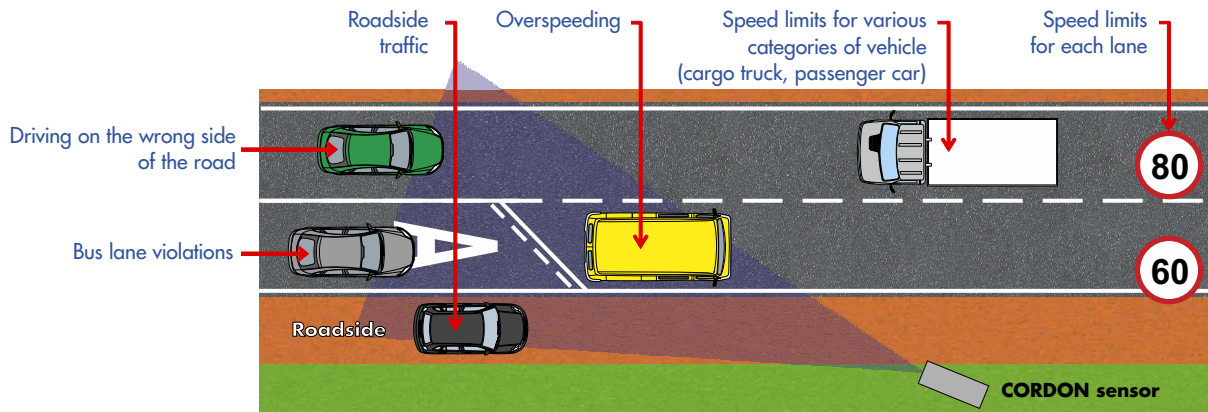

The violation data includes the recognized license plate number, measured speed, type of violation (speeding, roadside driving, bus lane driving or driving in wrong direction), movement direction, date and time of violation, speed limit for current road section, name of controlled road section, geographical coordinates, sensor serial number.

The system concurrently measures and captures all targets travelling in both directions within the controlled area.

The principal feature – license plate recognition is performed throughout the whole controlled area.

The archive of video clips and recorded violation data is simultaneously saved to internal storage and can be transferred to Police back office through secure wired or wireless communication lines for further processing.

INSTALLATION OPTIONS

The system has various installation and power supply options which may be used depending on tasks and technical capabilities on desired installation places.

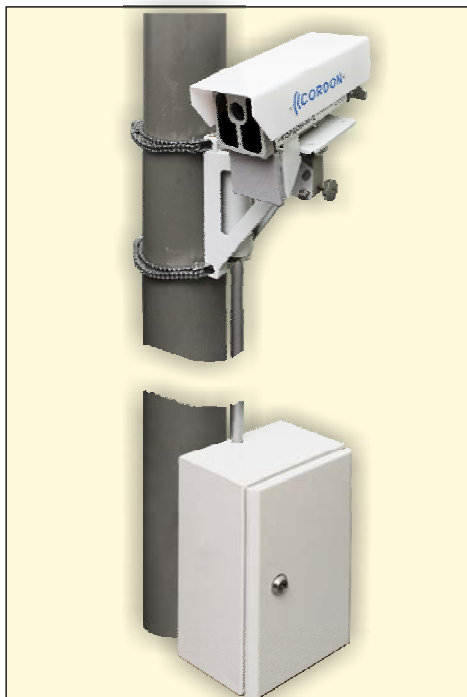

POWER SOURCE

The system is installed on the roadside at height of 3-5 meters using the mounting bracket on any lighting pole or similar support. The mains power supply is not required, as the system is powered by replaceable battery in tamper-proof housing.



MOBILE

The system is installed on a tripod at height of about 1.5 meters (breast height) at the roadside. The system is powered from battery box placed near the tripod and can be quickly transferred to another installation place.



STATIONARY

The system is installed at height of up to 10 meters using the mounting bracket on any lighting pole or similar support. The power comes from 110-220 V mains supply. The installation may take place either above the road or on the roadside.

«SIMICON» LTD.

Address: 8, Mendeleevskaya str, Saint-Petersburg, Russia, 194044

Phone: +7 (812) 295-0009, 295-0633 Fax: +7 (812) 324-6151

E-mail: contact@simicon.com