

IDEAL MORTAR PUMP

Features :

- ❖ Compact design consists of Mixer, Stone Filter, Hopper Mixer, and Peristaltic Pump.
- ❖ Mechanical operated with electrical speed control to meet all job demands.
- ❖ Enables pumping of heavy, fibered, thick, and abrasive materials at high volumes.
- ❖ The pump's mechanical maintenance is limited to hose wear. Pumped material does not come in contact with any moving parts.
- ❖ With a symmetric design, forward motion of material is constant, thus eliminating back pressure, and is perfectly reversible.
- ❖ Replacement of hose is quick and easy.
- ❖ Heavy Duty chassis and tough construction.



MODEL : IDS-980



CONCRETE DELIVERY PIPE

- 3 METER STRAIGHT
- 2 METER STRAIGHT
- 1 METER STRAIGHT
- 45° BEND
- 90° BEND

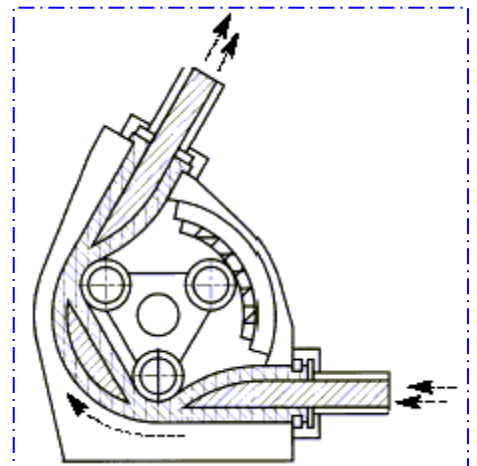

Technical Specification

Model	IDS-980
Voltage	415V
Power	5HP
Spray Capacity	10 – 85 Liter / Min
Delivery Distance	Radius 250 Meter Vertical 100 Meter
Size (L x W x H)	1800mm x 1360mm x 1430mm
Weight	650KG