



Selection Manual of Hybrid Stepper Servo Series

www.ims.com.my

Hybrid Stepper Servo Driver



Overview of hybrid stepping servo system	02
Application range of hybrid stepper servo drive system	03
Hybrid stepper Servo drive	04-20
Naming rules for hybrid stepper servo drives	04
Model of driver and electrical specifications	04
2HSS57/2HSS86H	05-08
2HSS57-N/2HSS86H-N	09-12
2HSS458/2HSS858H/2HSS1106H	13-16
3HSS2206H/3HSS2208H	17-20

Hybrid stepper servo motor



Name rule of hybrid stepper servo driver	21
Hybrid stepper servo motor list	21
Installation dimension drawing of motor	22-26
Torque characteristic diagram of motor	27-28
integrated stepper servo motor	29-30

>>>

Overview of Hybrid Stepper Servo Driver

Performance profile

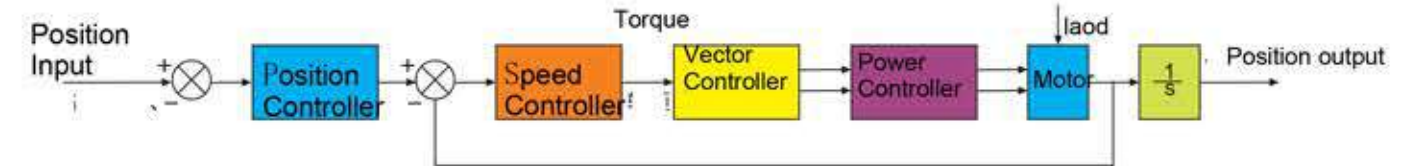

Main features

1. Full closed loop 2. High efficiency 3 Low heat 4 Low noise 5 Smooth precision 6 High speed response 7 Large Torque 8 High speed 9. High Voltage 220V drive, six-digit digital display, easy to set parameters and monitor the running state of motor.

Smooth, precise

Based on the feedback encoder space vector current control algorithm and vector smoothing filter technology, it can resist the "low frequency resonance" which puzzles the traditional stepping motor. Thus, the motor can be kept stable and quiet when it is applied at low speed. Perfect solution to the traditional stepping motor low-speed vibration noise

High speed feedback

1. Hybrid servo system retains some advantages of traditional open-loop stepping system, the position response output and input signal are almost synchronous, so it is very suitable for short-distance quick start-stop and zero-speed steady-stop.

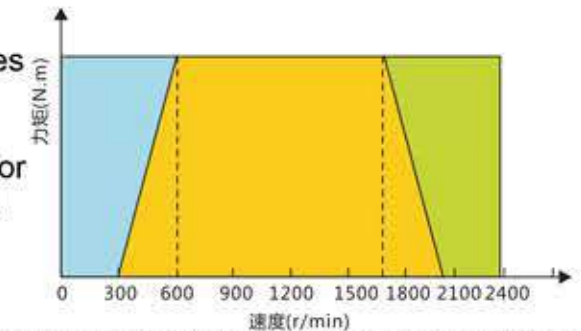

2. In the case of fast point-to-point positioning, advanced servo control technology provides high torque output, which makes the system have very high dynamic response and exceed the limit of traditional stepping system.

Big Torque/high Speed

1. The Hybrid servo drive system adopts the optimized current control mode, the torque of the motor can be fully utilized by 100% , and the system design does not need to consider the torque redundancy.

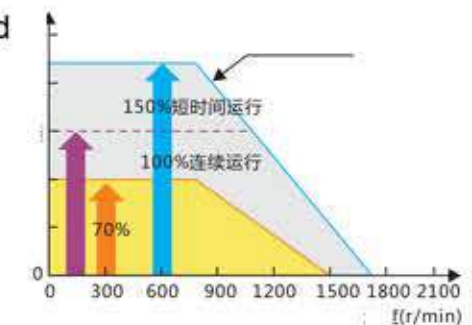

2. In some cases, high torque output can simplify the complexity of the decelerating mechanism.

3. The high-speed performance of the hybrid servo drive system is improved to over 70% of the constant torque, so that the motor can keep high torque during the high-speed process.

Hybrid step servo application system

Suitable for all kinds of small and medium-sized automatic equipment and instruments, such as: carving machine, stripping machine, cutting machine, laser machine, plotter, CNC machine, automatic equipment, electronic processing equipment, textile and garment equipment, etc. , it works especially well on devices that users expect to have low noise and high speed.



Hybrid Step Servo Driver

Driver naming rules
Driver model and electrical specifications
Closed-loop stepping system

Driver standard wiring diagram
Driver interface
Driver installation dimensions



Driver naming rules

2 HSS 86 H - X X X

- ① Phase; 2-2 phase; 3-3 phase
② Hybrid stepper servo

③ It can match with step servo motor or power supply, voltage level
57:57 series step servo motor ;86:86 series step servo motor
110:110 series step servo motor; 220: the power supply of power is 220VAC

④ H- with fans, lack of H means no fans

⑤ Product design serial number, the default is the standard model. 2HSS86H means two-phase stepping servo driver with fan can be equipped with 86 series closed-loop hybrid stepping servo motor.

Driver model and electrical specifications

Hybrid step servo driver									
Model									
	2HSS57	2HSS86H	2HSS57-N	2HSS86H-N	2HSS458	2HSS858H	2HSS1106H	3HSS2206H	3HSS2208H
Voltage	DC(24-60V)	DC(30-100V) AC(24-80V)	DC(24-60V)	DC(30-100V) AC(24-80V)	DC(24-48V)	DC(60-120V) AC(50-90V)	AC(50-130V)	AC(110-250V)	AC(110-250V)
Current	0-6A	0-6A	0-7A	0-7A	0-7A	0-6A	0-6A	0-6A	0-8A
Amplitude value	5-24V								
Pulse frequency	Maximum pulse frequency: 200Khz Standard (optional 500 KHz version)								

Composition of hybrid stepping servo system



2HSS57/2HSS86H

Standard wiring diagram of driver

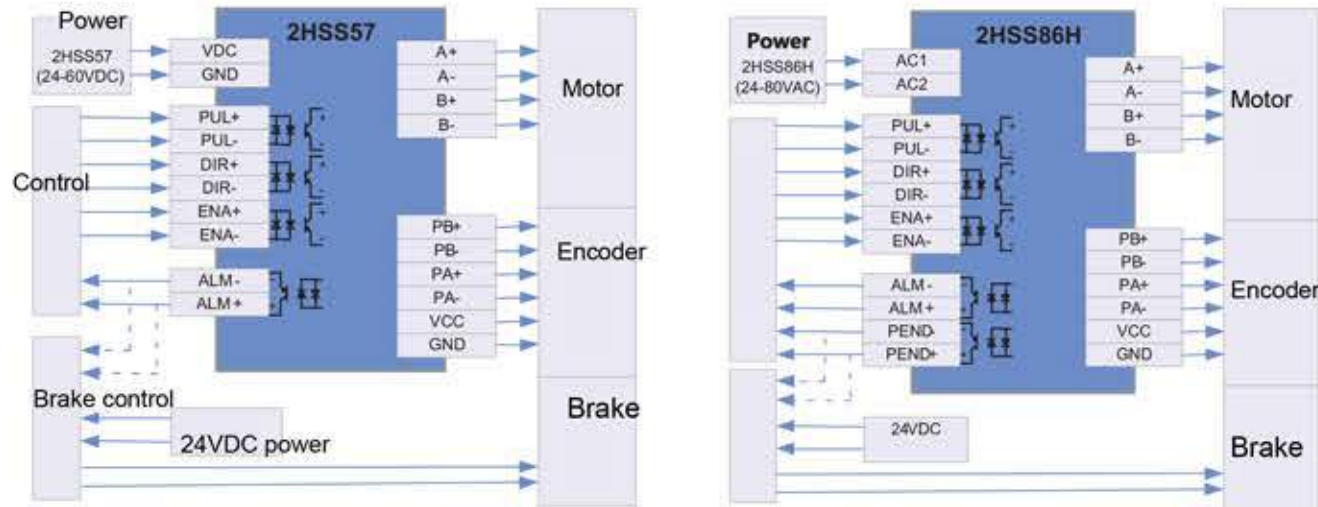

Note: The 2HSS57 drive Suffix is -SCJE, and the ALM output is used to control the brakes. Note: The 2HSS86 drive Suffix is -SCJE, and the PEND output is used to control the brake

Introduction of driver interface



False alarm and LED flashing number

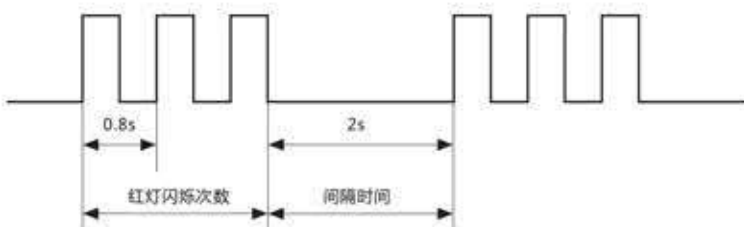

Number of red light flashes	Alarm
1	Drive over current
2	Drive internal voltage reference error
3	Drive parameter upload error
4	Supply voltage of driver exceeding maximum value
5	Drive offset position exceeds set value
6	Motor phase missing alarm

2HSS57/2HSS86H

Dial switch setting

Input edge setting(2HSS57/2HSS86H)

SW1	OFF	ON
	The rising edge is valid	Falling Edge is valid

Logical Direction setting(2HSS57/2HSS86H)

SW2	OFF	ON
	Counterclockwise	clockwise

Subdivision setting(2HSS57/2HSS86H)

The subdivision settings are as follows, when SW3, SW4, SW5, SW6 are all set to on, this value can be set by HISU parameter P20

Subdivision	Dial switch SW3	SW4	SW5	SW6
Default	on	on	on	on
800	off	on	on	on
1600	on	off	on	on
3200	off	off	on	on
6400	on	on	off	on
12800	off	on	off	on
25600	on	off	off	on
51200	off	off	off	on
1000	on	on	on	off
2000	off	on	on	off
4000	on	off	on	off
5000	off	off	on	off
8000	on	on	off	off
10000	off	on	off	off
20000	on	off	off	off
40000	off	off	off	off

Control signal sequence diagram

To avoid some errors and deviations, PUL, DIR, and ENA should meet certain requirements, as shown in the following figure

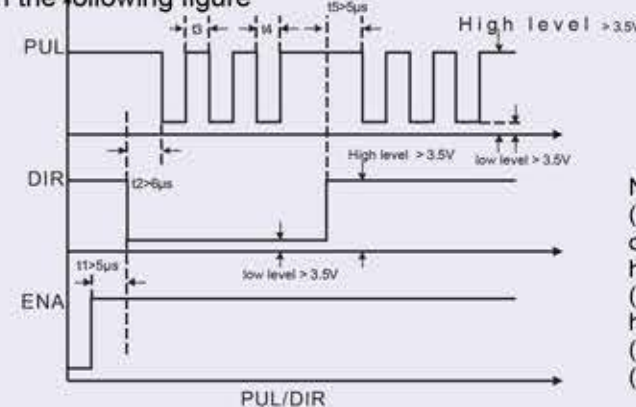

Note:
 (1) T1: ENA(enable signal) should be at least 5μs ahead of DIR, determined as high. In general, ENA + and ENA- hover are ok.
 (2) T2: DIR determines whether the PUL count edge is high or low at least six seconds in advance.
 (3) T3: Pulse width not less than 2.5μs.
 (4) T4: Low level width not less than 2.5μs

2HSS57/2HSS86H

◆ 232 serial port communication wiring diagram

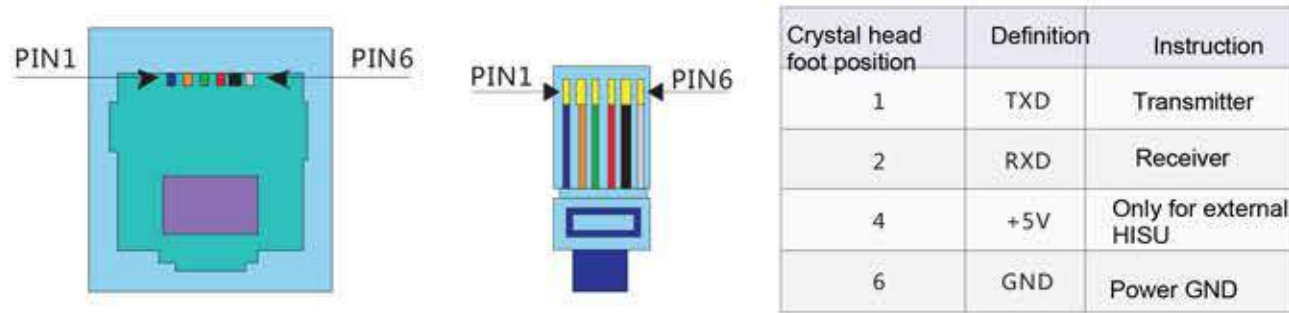

◆ Power input interface

Name	Definition of interface	Remark	
VDC/AC1	Power input +	The interface of 2HSS86H is labeled as AC, and the range of driver supply voltage is	
GND/AC2	Power input GND	Driver	
		Power supply range	
		2HSS57	24VDC~60VDC
		2HSS86H	24VAC~80VAC



Name	Definition of interface	Color
A+	Motor winding A phase drive output+	red
A-	Motor winding A phase drive output-	Blue
B+	Motor winding B phase drive output+	Green
B-	Motor winding B phase drive output-	Black



Pin NO.	Sign	Definition of interface	Color
1	PB+	Encoder B phase input +	Blue
2	PB-	Encoder B phase input -	White
3	PA+	Encoder A phase input +	Yellow
4	PA-	Encoder A phase input -	Green
5	VCC	Encoder power +	red
6	GND	Encoder power -	Black

2HSS57/2HSS86H

◆ Control signal input interface

Pin No.	Symbol	Interface definition	Instruction
1	PLS+	Pulse input+	Compatible with 5V and 24v signal
2	PLS-	Pulse input-	
3	DIR+	Direction input+	
4	DIR-	Direction input-	
5	ENA+	Enable input+	
6	ENA-	Enable input-	

◆ ALM signal output interface

Pin No.	Symbol	Interface definition	Instruction
1	ALM+	Alarm output+	
2	ALM-	Alarm output-	

◆ In position signal output interface(2HSS86H has PEND signal output,2HSS57 doesn't have)

Pin No.	Symbol	Name	Instruction
1	PEND+	In position output+	
2	PEND-	In position output-	

Mountion dimension of driver

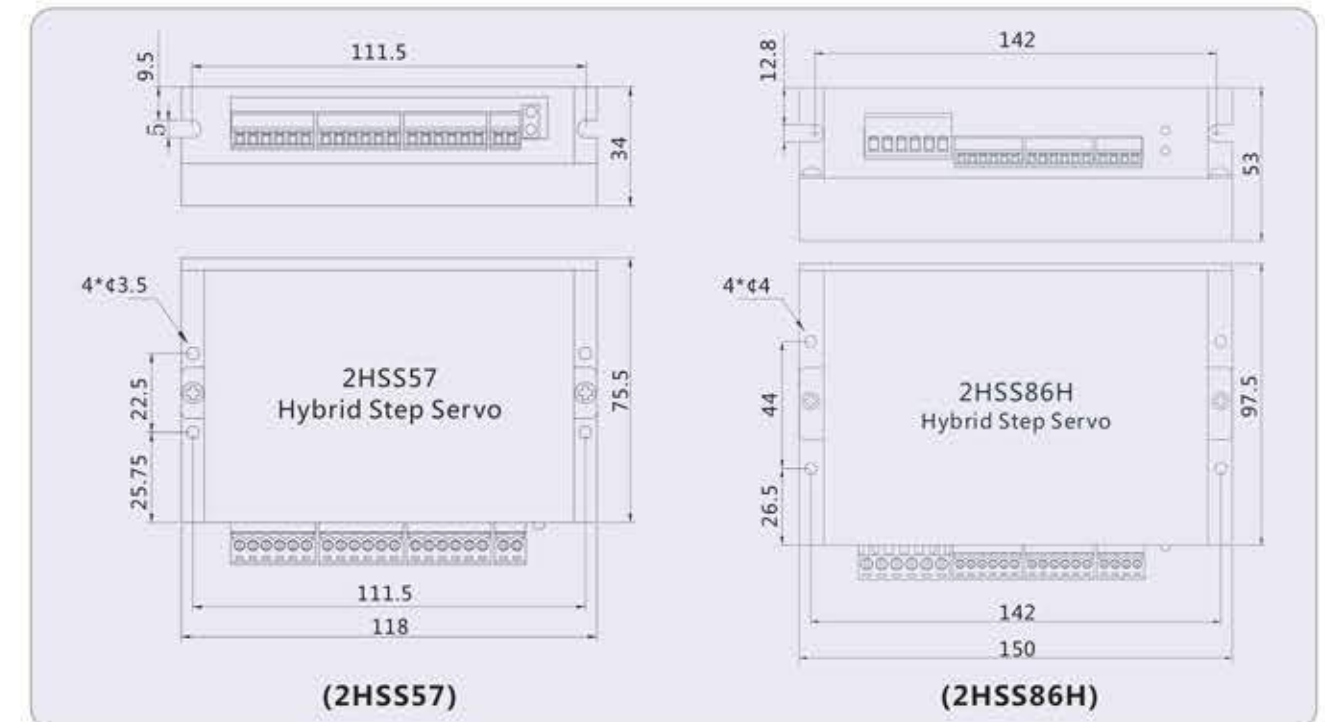

2HSS57-N/2HSS86H-N

standard wiring diagram of driver

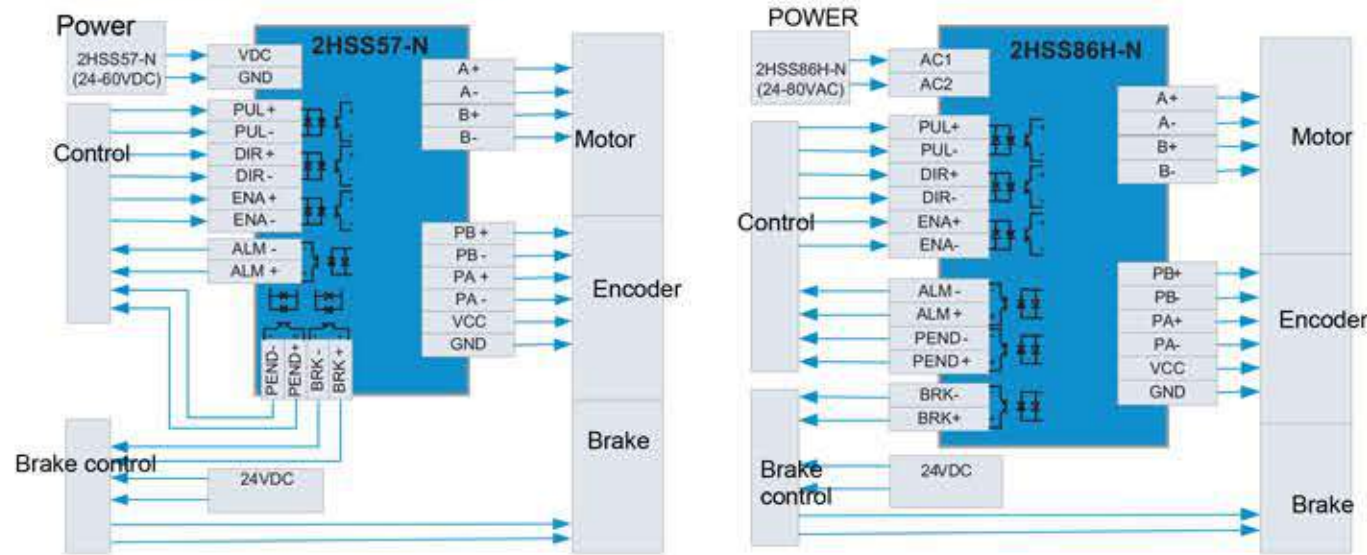

Introduction of driver interface

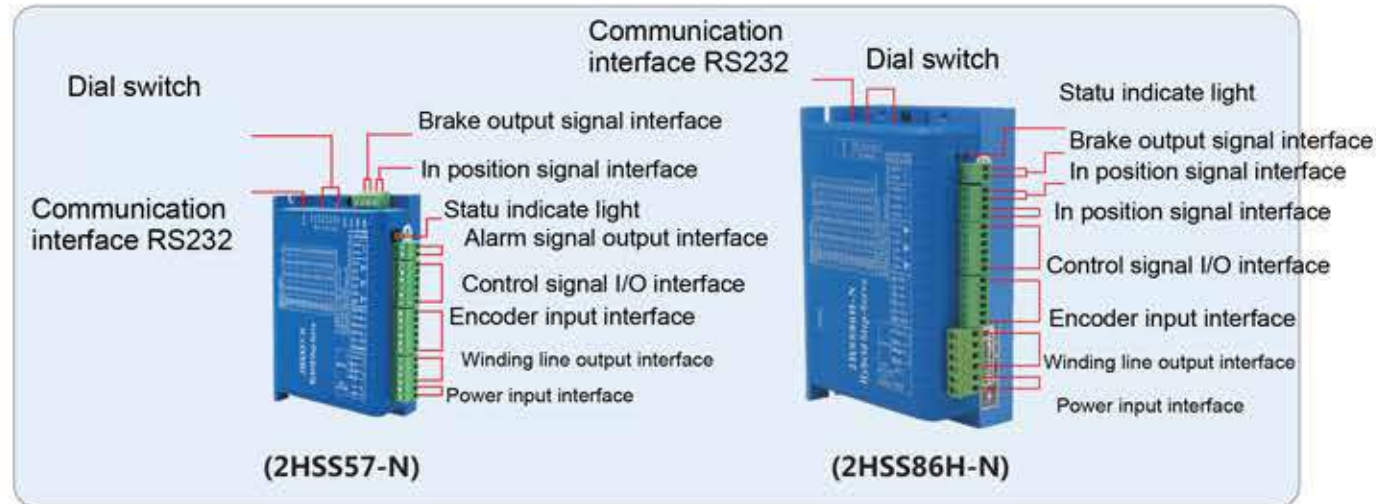

False alarm and LED flashing number

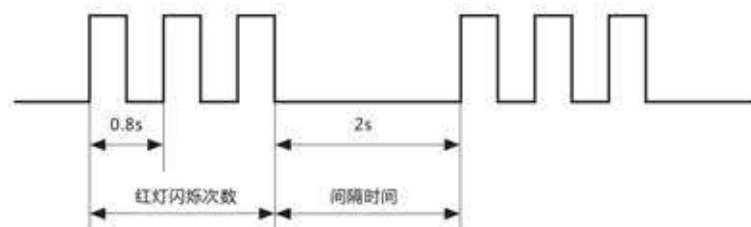

Flash No.of red light	Alarm instruction
1	Drive over current
2	Drive internal voltage reference error
3	Drive parameter upload error
4	Supply voltage of driver exceeding maximum value
5	Drive offset position exceeds set value
6	Motor phase missing alarm

2HSS57-N/2HSS86H-N

Dial switch setting

① Single/double pulse setting(2HSS57-N/2HSS86H-N)

SW1	OFF	ON
	Single pulse	Double pulse

② Logical Direction setting (2HSS57-N/2HSS86H-N)

SW2	OFF	ON
	Counterclockwise	Clockwise

Subdivision setting

The subdivision settings are as follows, when SW3, SW4, SW5, SW6 are all set to on, this value can be set by HISU parameter P20

Subdivision	Dial switch			
	SW3	SW4	SW5	SW6
Default	on	on	on	on
800	off	on	on	on
1600	on	off	on	on
3200	off	off	on	on
6400	on	on	off	on
12800	off	on	off	on
25600	on	off	off	on
51200	off	off	off	on
1000	on	on	on	off
2000	off	on	on	off
4000	on	off	on	off
5000	off	off	on	off
8000	on	on	off	off
10000	off	on	off	off
20000	on	off	off	off
40000	off	off	off	off

④ Instruction smoothing setting(2HSS57-N/2HSS86H-N)

SW7	OFF	ON
	close	Open

⑤ Setting of motion mode (2HSS57-N/2HSS86H-N)

SW8	OFF	ON
	Closed loop model	Open loop model

2HSS57-N/2HSS86H-N

◆ Control signal sequence diagram

To avoid some errors and deviations, PUL, DIR, and ENA should meet certain requirements, as shown in the following figure

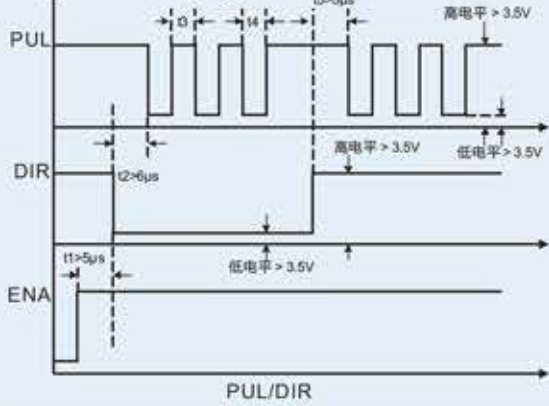

Note:

- (1) T1: ENA(enable signal) should be at least 5µs ahead of DIR, determined as high. In general, ENA + and ENA- hover are ok.
- (2) T2: DIR determines whether the PUL count edge is high or low at least six seconds in advance.
- (3) T3: Pulse width not less than 2.5µs.
- (4) T4: Low level width not less than 2.5µs

◆ 232 serial port communication wiring diagram

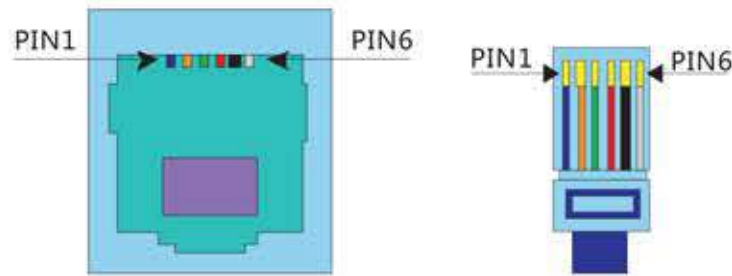

Crystal head foot position	Definition	Instruction
1	TXD	Transmitter
2	RXD	Receiver
4	+5V	Only for external HISU
6	GND	Power GND

◆ Power input interface

Name	Instruction of interface	Remark	
VDC/AC1	Power input +	The interface of 2HSS86H-N is labeled as AC, and the range of driver supply voltage is	
GND/AC2	Power input GND	Driver	Supply power range
		2HSS57-N	24VDC~60VDC
		2HSS86H-N	24VAC~80VAC

◆ Encoder feedback signal input interface

Pin NO.	Symbol	Instrucion of interface	Color
1	PB+	Encoder B phase input+	Blue
2	PB-	Encoder B phase input-	white
3	PA+	Encoder A phase input+	Yellow
4	PA-	Encoder A phase input-	Green
5	VCC	Encoder power+	Red
6	GND	Encoder power-	Black

2HSS57-N/2HSS86H-N

◆ Control signal input interface

Pin No.	Symbol	instruction of interface	Definition
1	PLS+	pulse input +	Compatible with 5V and 24V signal
2	PLS-	Pulse input-	
3	DIR+	Direction input +	
4	DIR-	Direction input-	
5	ENA+	Enable input +	
6	ENA-	Enable input-	

◆ Position Signal output port (2HSS57-N/2HSS86H-N)

Pin NO.	Symbol	instruction of interface	Definition
1	PEND+	Inposition output+	
2	PEND-	Inposition output-	

◆ ALM signal output interface(2HSS57-N/2HSS86H-N)

Pin No.	Symbol	instruction of interface	Definition
1	ALM+	Alarm output+	
2	ALM-	Alarm output -	

◆ Brake output interface (2HSS57-N/2HSS86H-N)

Pin No.	Symbol	instruction of interface	Definition
1	BRK+	In position ouput +	
2	BRK-	In position ouput -	

Mounting dimension of driver

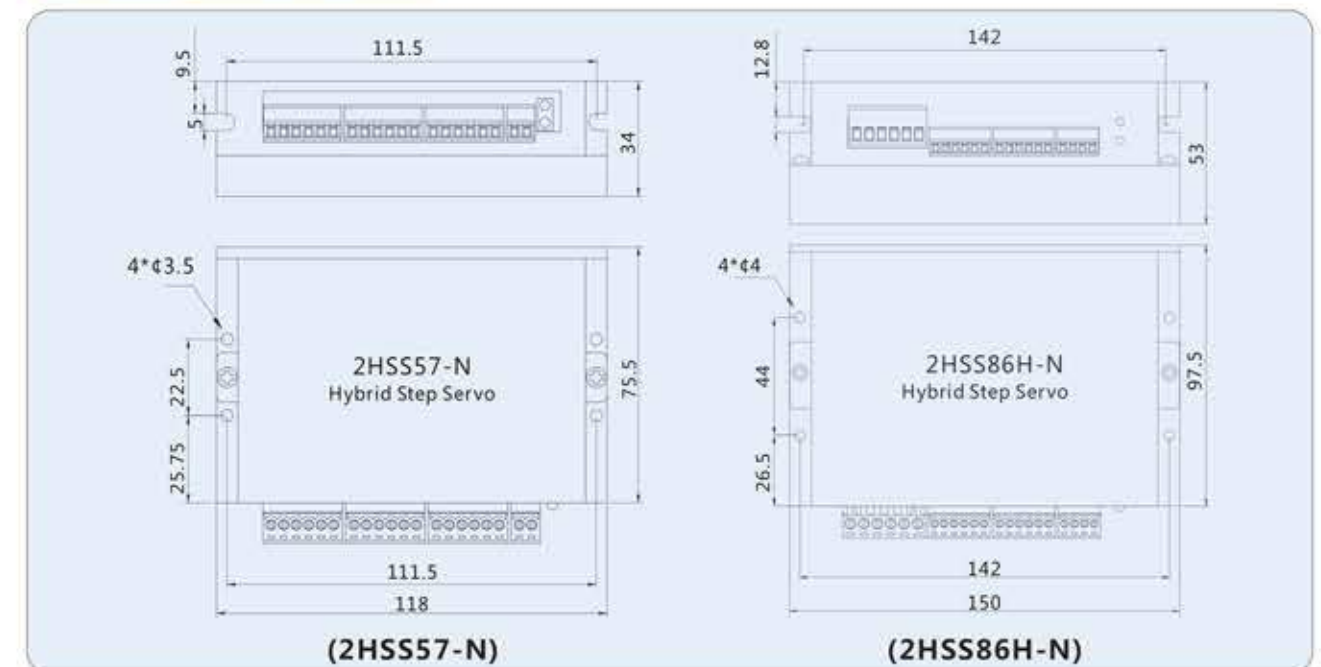

2HSS458/2HSS858H/2HSS1106H

standard wiring diagram of driver

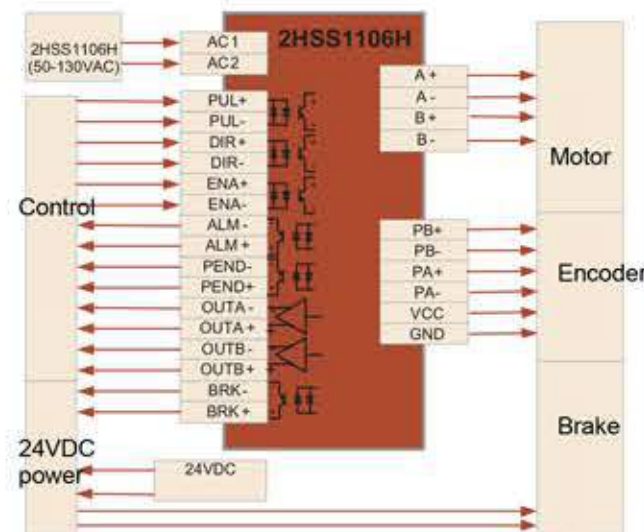
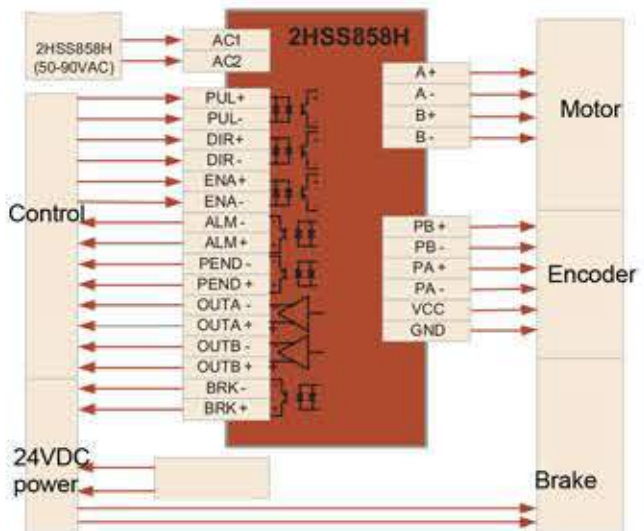
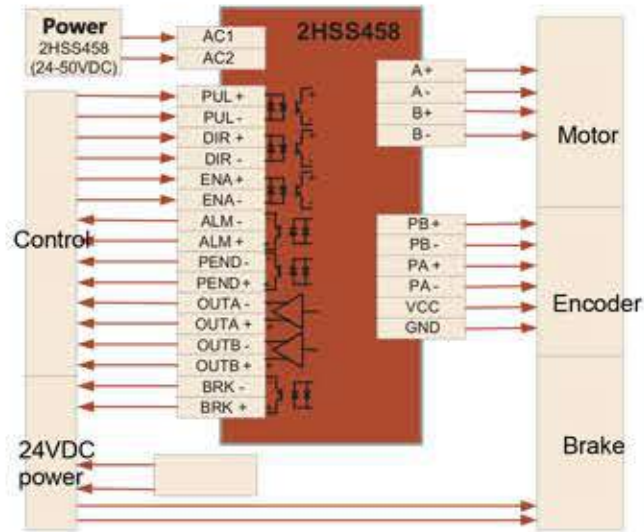

Driver display and interface description

Fault Display Code

Fault display	Fault reason
01.Err	Over current
11.Err	Motor voltage reference error
22.Err	Motor parameter upload error
33.Err	Power over voltage alarm
44.Err	Position deviation over alarm
55.Err	Motor lack of phase alarm
En_OFF	Driver is out

Statu indicate



Symbol	Instruciton
M	Undo exit, function switch key
ENT	Ok Save key
←	Shift function
↑	Parameter adjustment, add function
↓	Parameter adjustment, reduced function

Select the display mode by pressing the "M" key, and monitor the running state of the motor by selecting the up and down keys. Each monitoring code is shown in the following chart

LED display	Meaning
d00SPR	Reference speed
d01SPF	Feedback speed
d02PLE	Position deviation
d03PLR	Position given
d04PLF	Position feedback
xx_Err	Driver fault
En_OFF	Driver off line

Note:
Through the "M" switch to this function; that is, parameter display function; with the "ENT" key to see the parameter value (on the display is your final view of the parameter value), press the " " key or " " key magic function; (the ' ' key is invalid) exit this function and go to the next function press the "M" key

2HSS458/2HSS858H/2HSS1106H

Control signal sequence diagram

To avoid some errors and deviations, PUL, DIR, and ENA should meet certain requirements, as shown in the following figure

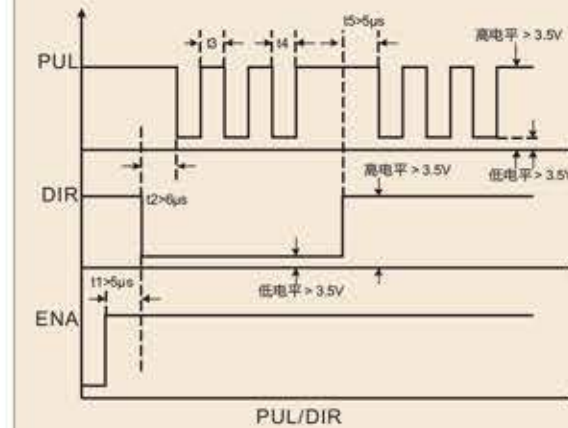

Note:
(1) T1: ENA(enable signal) should be at least 5µs ahead of DIR, determined as high. In general, ENA+ and ENA- hover are ok.
(2) T2: DIR determines whether the PUL count edge is high or low at least six seconds in advance.
(3) T3: Pulse width not less than 2.5µs.
(4) T4: Low level width not less than 2.5µs

Introduction to driver interface

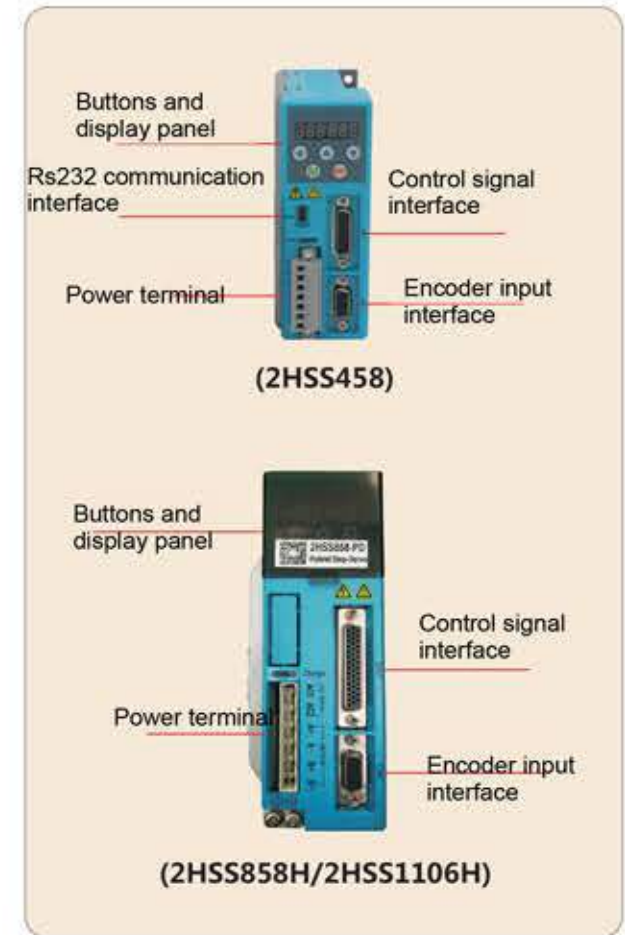

Power input interface

Name	Definition of interface	rRemark
VDC/AC1	Power input +	The interface of 2HSS86H/2HSS1106Hs labeled as AC, and the range of driver supply voltage is Driver Power supply range
GND/AC2	Power input GND	
		2HSS458 24VDC~50VDC
		2HSS858H 50VAC~90VAC
		2HSS1106H 50VAC~130VAC

Motor output interface

Name	Definition of interface	Color
A+	Motor winding A phase drive output+	Red
A-	Motor winding A phase drive output-	Blue
B+	Motor winding B phase drive output+	Green
B-	Motor winding B phase drive output-	Black

2HSS458/2HSS858H/2HSS1106H

◆ Motor output interface

Name	Definition of interface	Color
A+	Motor winding A phase drive output+	Red
A-	Motor winding A phase drive output-	Blue
B+	Motor winding B phase drive output+	Green
B-	Motor winding B phase drive output-	Black

◆ Encoder feedback signal input interface

Db head pin	Signal	Instruction of interface
1	EA+	Encoder A phase input+
2	EB+	Encoder B phase input+
3	GND	Encoder power GND
4	EA-	Encoder A phase input-
5	EB-	Encoder A phase input-
6	VCC	encoder power +

◆ Control signal input interface

[2HSS458]

Db head pin	Symbol	Name	Instruction
1	ENA+	Enable input +	Compatible with 5V and 24V signal
2	ENA-	Enable input -	
3	PUL+	Pulse input +	Compatible with 5V and 24V signal
4	PUL-	Pulse input -	
5	DIR+	Direction input+	Compatible with 5V and 24V signal
6	DIR-	Direction input-	
7	Keep	Keep	Keep
8	Keep	Keep	Keep
9	Keep	Keep	Keep
10	PEND+	Inposition signal output+	
11	PEND-	Inposition signal output-	
12	ALM+	Alarm output +	
13	ALM-	Alarm output -	
20	OUTA+	Encoder A phase output +	
21	OUTA-	Encoder A phase output -	
22	OUTB+	Encoder B phase output +	
23	OUTB-	Encoder B phase output -	
24	OUTZ+	Encoder Z phase output +	
25	OUTZ-	Encoder Z phase output -	

[2HSS858/2HSS1106H]

Terminal number	Symbol	Name	Instruction
1	IN1+	Input 1 interface +	Function keep
2	IN1-	Input 1 interface-	Function keep

2HSS458/2HSS858H/2HSS1106H

3	PUL+	Pulse input +	Compatible with 5V and 24V signal
4	PUL-	Pulse input -	
5	DIR+	Direction input+	Compatible with 5V and 24V signal
6	DIR-	Direction input-	
7	ALM+	Alarm input +	
8	ALM-	Alarm input-	
9	PEND+	In position signal output+	
10	PEND-	In position signal output-	
11	ENA+	Enable input +	Compatible with 5V and 24V signal
12	ENA-	Enable input -	
13	OUTZ+	Encoder Z phase+	
29	OUTZ-	Encoder Z phase-	
14	OUTB+	Encoder B phase+	
15	OUTB-	Encoder Z phase-	
32	BRAKE+	Brake B phase +	
31	BRAKE-	Brake B phase -	
30	OUTA-	Encoder A phase-	
44	OUTA+	Encoder A phase+	

Mounting dimension of driver

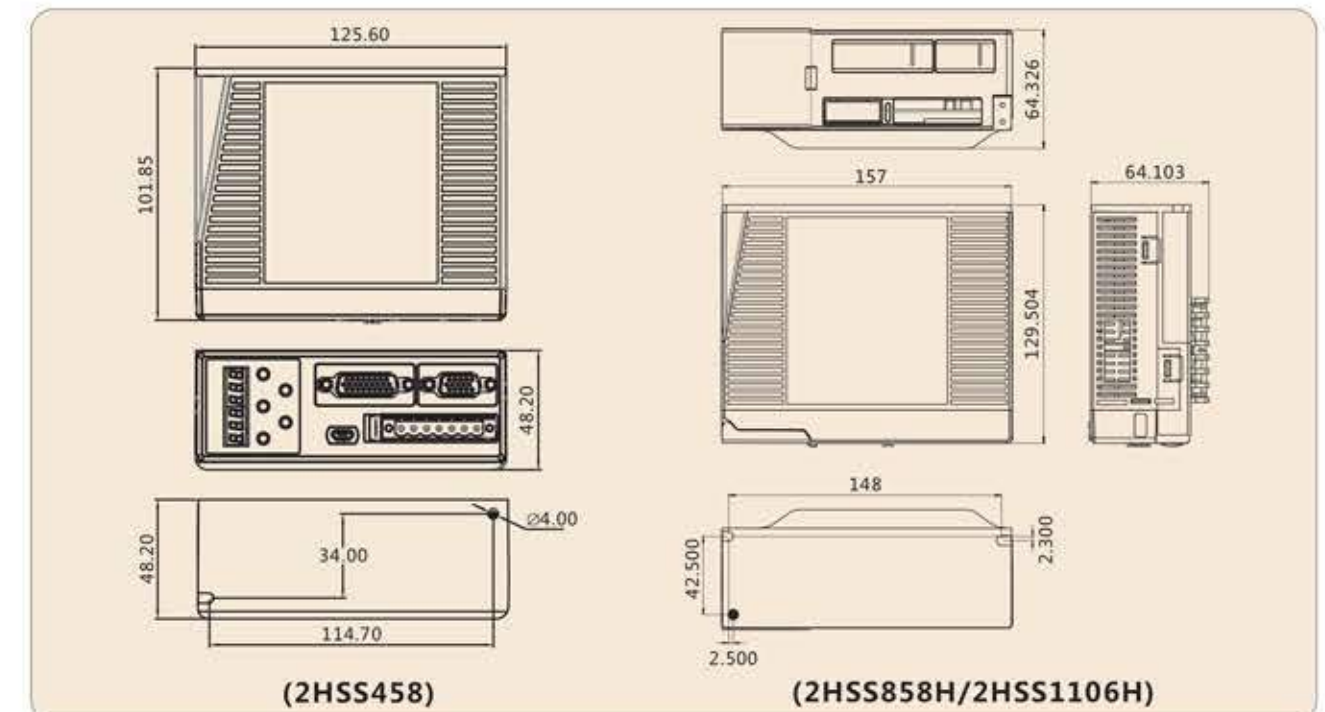

3HSS2206H/3HSS2208H

Standard wiring diagram of driver

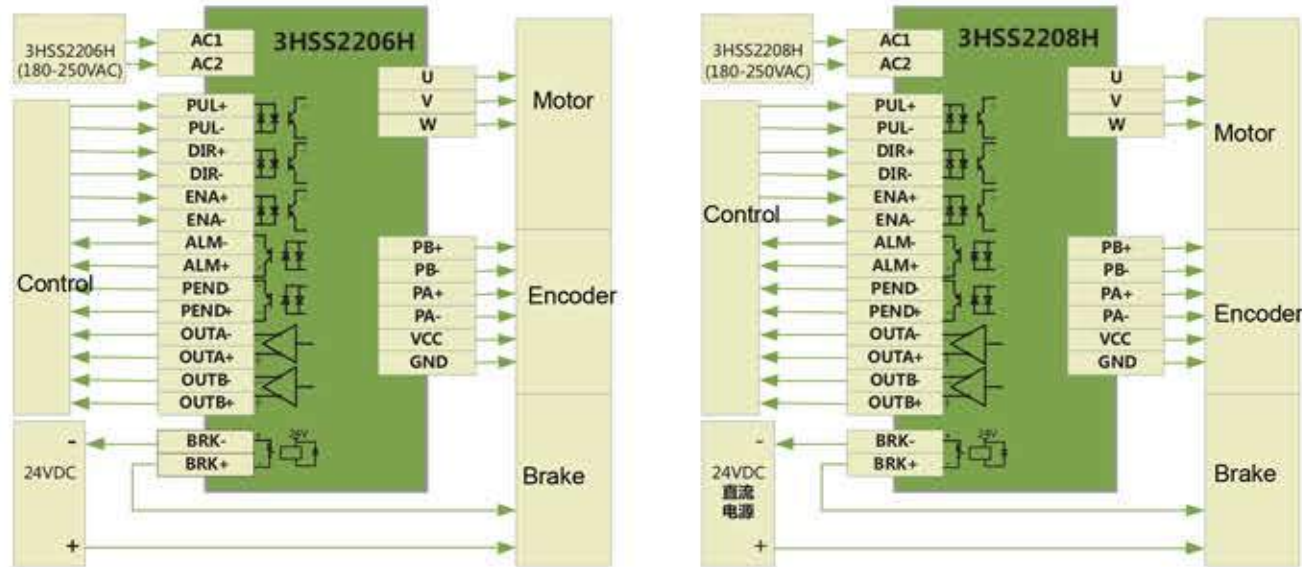

Driver display and interface description

Fault indication code

Fault indication	Fault reason
00.Err	Over current
11.Err	Motor voltage reference error
22.Err	Motor parameter upload error
33.Err	Power over voltage alarm
44.Err	Position deviation over alarm
55.Err	Motor lack of phase alarm
En_OFF	Driver log off

Status Indication

Key Symbol	instruction
M	Undo exit, function switch key
ENT	Comfirm and save
◀	Swift function
▲	Adjust parameters,add function
▼	Adjust parameters,reduce function

3HSS2206H/3HSS2208H

Select the display mode by pressing the "M" key, and monitor the running state of the motor by selecting the up and down keys. Each monitoring code is shown in the following chart

LED display	Meaning
d00SPR	Reference speed
d01SPF	Feedback speed
d02PLE	Position deviation
d03PLR	Position given
d04PLF	Position feedback
xx_Err	Driver fault
En_OFF	Driver off line

Note:

Through the "M" switch to this function; that is, parameter display function; with the "ENT" key to see the parameter value (on the display is your final view of the parameter value), press the " " key or " " key magic function; (the " " key is invalid) exit this function and go to the next function press the "M" key

Control signal sequence diagram

To avoid some errors and deviations, PUL, DIR, and ENA should meet certain requirements, as shown in the following figure

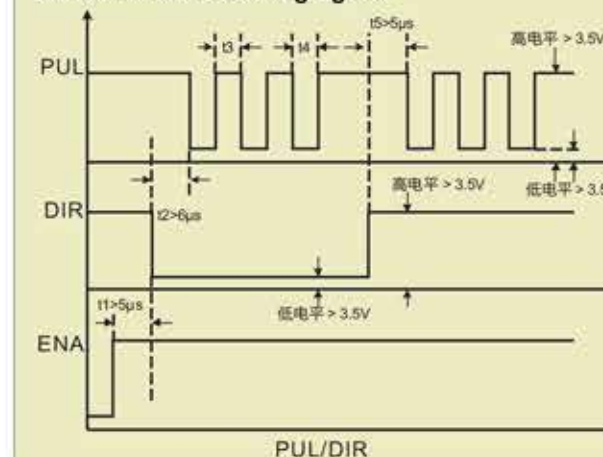

Note:

- (1) T1: ENA(enable signal) should be at least 5µs ahead of DIR, determined as high. In general, ENA+ and ENA- hover are ok.
- (2) T2: DIR determines whether the PUL count edge is high or low at least six seconds in advance.
- (3) T3: Pulse width not less than 2.5µs.
- (4) T4: Low level width not less than 2.5µs

Interface of driver

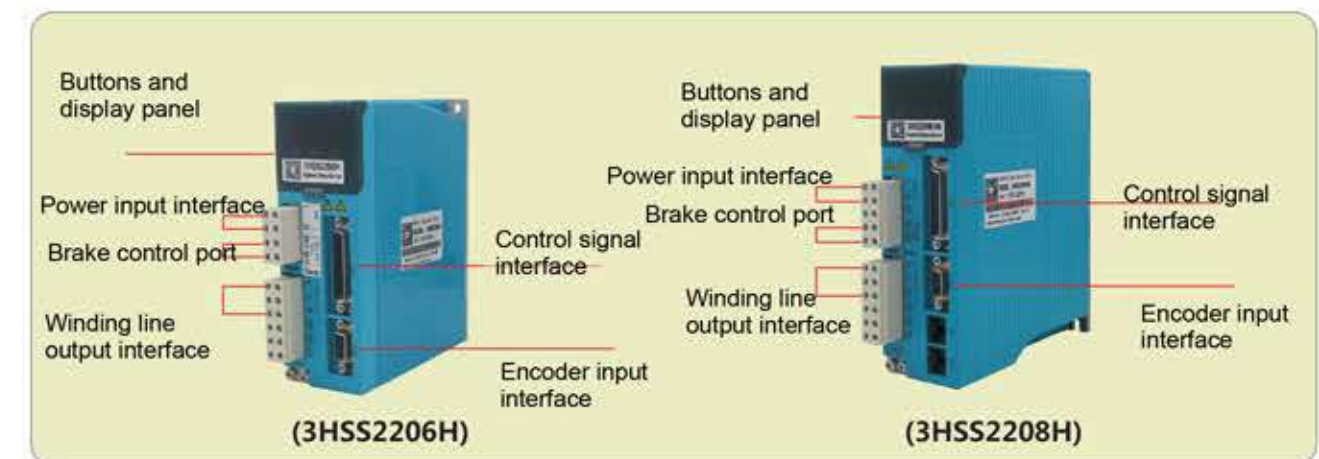

3HSS2206H/3HSS2208H

◆ Power input interface

Name	Instruction of interface	Power range
L	Power input L	180~250VAC
N	Power input N	

◆ Motor control interface

Name	Instruction of interface
Break+	Brake+
Break-	Brake-

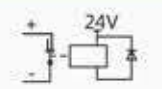

◆ Encoder feedback signal input interface

Name	Instruction of interface
U	Motor winding U phase drive output
V	Motor winding V phase drive output
W	Motor winding W phase drive output

◆ Encoder feedback signal input interface

Db head pin	Signal	Instruction of interface
1	EA+	Encoder A phase input +
2	EB+	Encoder B phase input +
3	GND	Encoder power GND
4	EA-	Encoder A phase input -
5	EB-	Encoder B phase input +
6	VCC	Encoder power +

3HSS2206H/3HSS2208H

◆ Control signal input interface

Pin No.	Symnl	Name	Instruction
1	IN1+	Input interface 1+	Function keep
2	IN1-	Input interface 1-	Function keep
3	PUL+	Pulse input +	Compatible with 5V and 24V signal
4	PUL-	Pulse input -	
5	DIR+	Direction input+	Compatible with 5V and 24V signal
6	DIR-	Direction input-	
7	ALM+	Alarm output +	
8	ALM-	Alarm output -	
9	PEND+	Inposition signal output+	
10	PEND-	nposition signal output-	

Pin No.	Symnl	Name	Instruction
11	ENA+	Enable input +	Compatible with 5V and 24V signal
12	ENA-	Enable input -	
13	OUTZ+	Encoder Z phase +	
29	OUTZ-	Encoder Z phase -	
14	OUTB+	Encoder B phase +	
15	OUTB-	Encoder B phase -	
30	OUTA-	Encoder A phase -	
44	OUTA+	Encoder A phase +	

Mounting dimension of driver

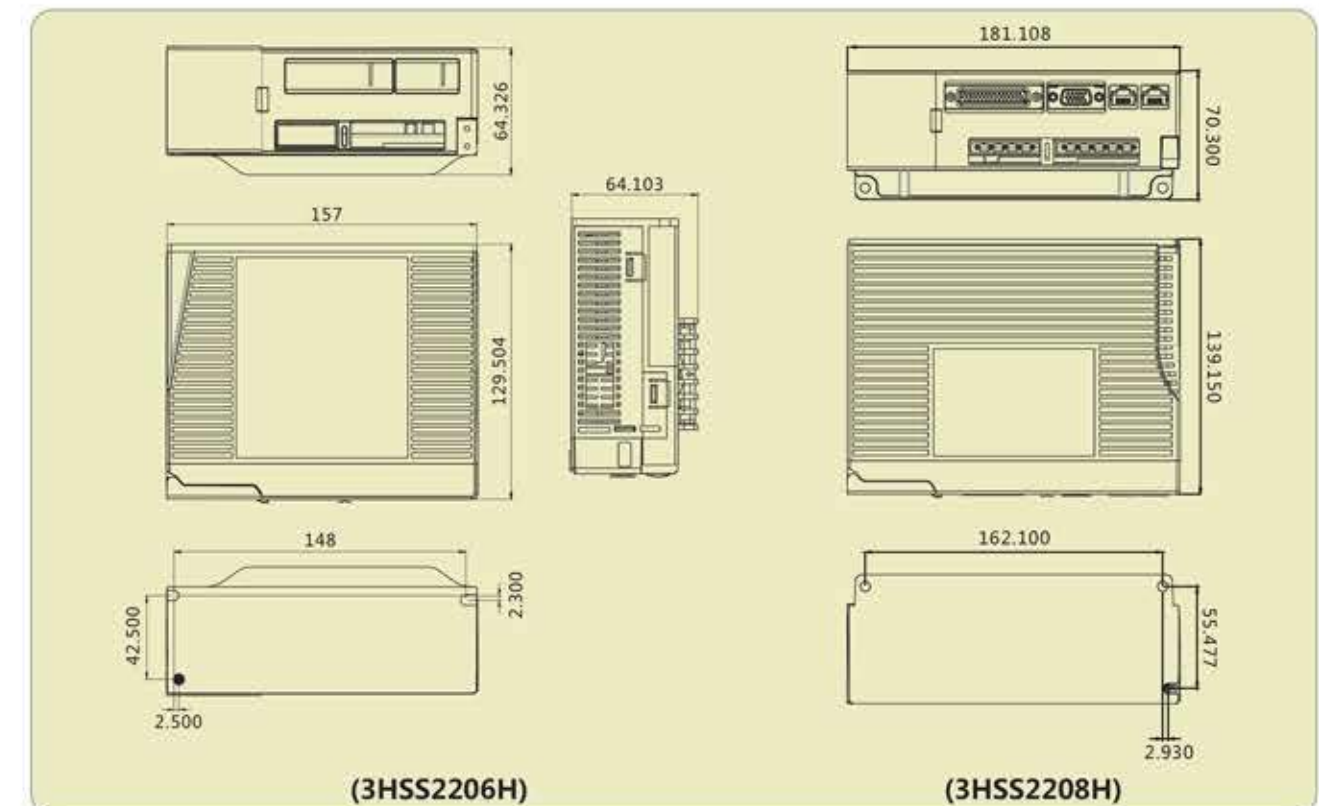

Hybrid stepper servo motor

Motor name rule

Motor installation dimension

Motor list

Speed-torque chart



Installation dimension of motor

Mounting dimensions for Standard Type closed-loop motors (Note: The following standard closed-loop Motor, shaft, Flange can be customized according to customer requirements)

Model	length (mm)	holding torque (N.m)	rated current (A)	rotational inertia (kg-cm ²)	Matched driver	Flange (mm)	Weight (kg)
42J1848EC-1000 (*)	48	0.48	1.5	0.08	2HSS57	22	0.45
42J1860EC-1000	60	0.7	2.5	0.11	2HSS57	22	0.55

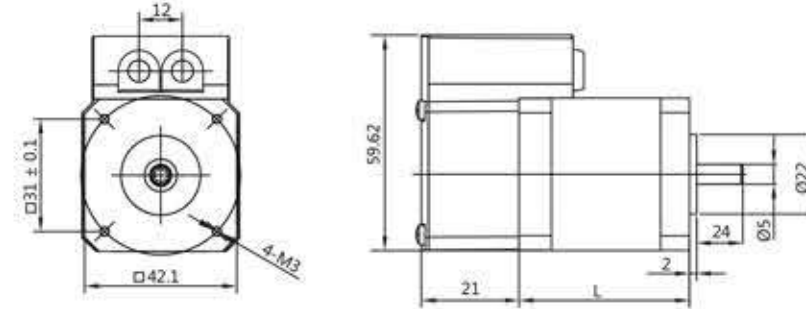

Model	Length (mm)	Holding torque (N.m)	Rated current (A)	Rotational inertia (kg-cm ²)	Matched driver	Flange (mm)	Weight (kg)
57J1854EC-1000 (*)	56	1.2	4	0.28	2HSS57	38.1	0.8
57J1880EC-1000 (*)	76	2	5	0.48	2HSS57	38.1	1.2

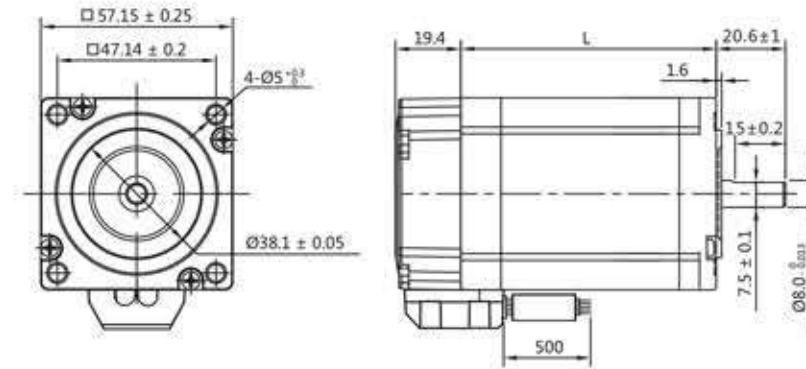

Model	Length (mm)	Holding torque (N.m)	Rated current (A)	Rotational inertia (kg-cm ²)	Matched driver	Flange (mm)	Weight (kg)
60J1856EC-1000	57	1.5	3.5	0.34	2HSS57	36	0.9
60J1887EC-1000 (*)	85.6	3	5	0.69	2HSS57	36	1.45
60J18100EC-1000	100	3.5	5	1.2	2HSS57	36	1.9

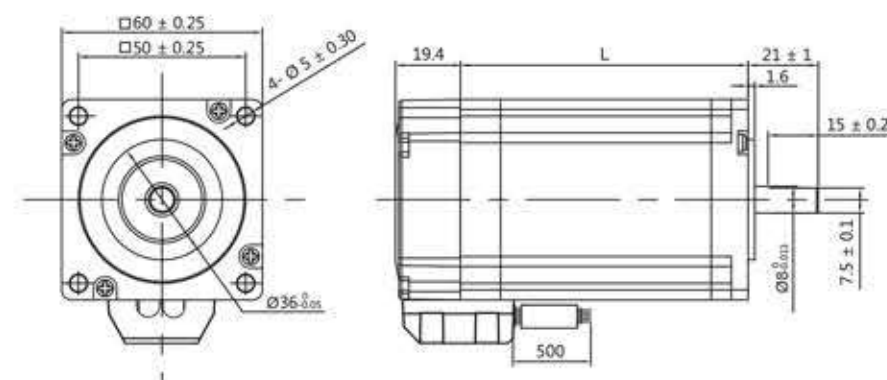

Motor name rule

86 J 18 118 EC - 1000

① ② ③ ④ ⑤ ⑥

1. Motor seat number
2. JMK stepping servo motor series
3. Step Angle: 18:1.8° two phase, 12:1.2° three phase
4. Motor length (MM)
5. Closed-loop function with encoder.
6. Encoder line number 1000 means 1000P/r, encoder line number 2500 means 2500P/r.

The example means: mounting flange is 86, 1.8°, 118 mm long and the encoder line is 1000.

Motor list

Motor seat No.	Model No.			Torque (Nm)	length of motor body (mm)		
	Standard series	Motor with brake	Waterproof				
Two phase	42	42J1848EC-1000 (*)	42J1848EC-1000-SC	42J1848EC-1000-FS	0.4	68	
		42J1860EC-1000	42J1860EC-1000-SC	42J1860EC-1000-FS	0.6	80	
	57	57J1854EC-1000 (*)	57J1854EC-1000-SC	57J1854EC-1000-FS	1.2	76	
		57J1880EC-1000 (*)	57J1880EC-1000-SC	57J1880EC-1000-FS	2.2	96	
	60	57J18100EC-1000	57J18100EC-1000-SC	57J18100EC-1000-FS	2.8	120	
		60J1856EC-1000	60J1856EC-1000-SC	60J1856EC-1000-FS	1.5	76	
		60J1887EC-1000 (*)	60J1887EC-1000-SC	60J1887EC-1000-FS	3.0	107	
	86	60J18100EC-1000	60J18100EC-1000-SC	60J18100EC-1000-FS	4.0	120	
		86J1880EC-1000 (*)	86J1880EC-1000-SC	86J1880EC-1000-FS	4.5	80	
		86J1895EC-1000 (*)	86J1895EC-1000-SC	86J1895EC-1000-FS	6.0	118	
		86J18118EC-1000 (*)	86J18118EC-1000-SC	86J18118EC-1000-FS	8.5	137	
	Three phase	86	86J18156EC-1000 (*)	86J18156EC-1000-SC	86J18156EC-1000-FS	12.0	173
86J12126EC-1000-60 (*)			86J12126EC-1000-60-SC	86J12126EC-1000-60-FS	8.0	149	
110		86J12156EC-1000-60 (*)	86J12156EC-1000-60-SC	86J12156EC-1000-60-FS	12.0	173	
		110J12135EC-1000 (*)	110J12135EC-1000-SC	110J12135EC-1000-FS	12.0	153	
		110J12160EC-1000 (*)	110J12160EC-1000-SC	110J12160EC-1000-FS	16.0	178	
130		110J12190EC-1000 (*)	110J12190EC-1000-SC	110J12190EC-1000-FS	20.0	210	
		130J12205EC-2500 (*)	130J12205EC-2500-SC	130J12205EC-2500-FS	28.0	257	
			130J12225EC-2500 (*)	130J12225EC-2500-SC	130J12225EC-2500-FS	35.0	277

Model	Length (mm)	Holding torque (N.m)	Rated current (A)	Rotational inertia (kg-cm ²)	Matched driver	Flange (mm)	Weight (kg)
86J1880EC-1000 (*)	80	4.5	6	1.4	2HSS86H	60/73	2.4
86J1895EC-1000 (*)	100	6.5	6	2.2	2HSS86H	73	3.4
86J18118EC-1000 (*)	114	8.5	6	2.7	2HSS86H/2HSS858	60/73	3.9
86J18156EC-1000 (*)	156	12	6	4.0	2HSS86H/2HSS1106	60/73	5.3

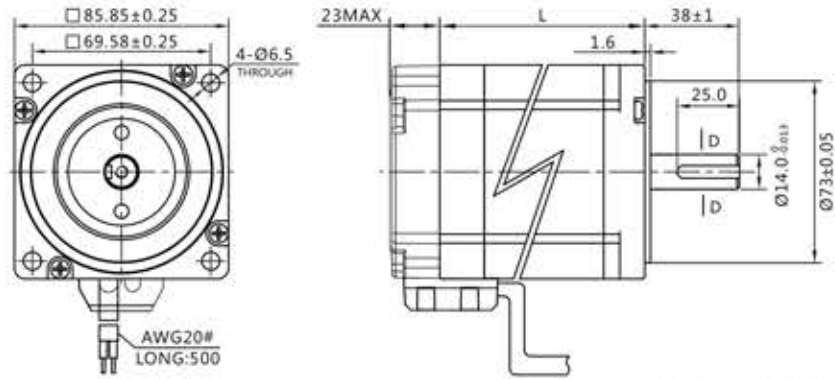

Model	Key (mm)
86J1880EC-1000	1.0x25
86J1895EC-1000	1.0x25
86J18118EC-1000	5.0x25
86J18156EC-1000	5.0x25

Model	Length (mm)	Holding torque (N.m)	Rated current (A)	Rotational inertia (kg-cm ²)	Matched driver	Flange (mm)	Weight (kg)
86J12126EC-1000-60 (*)	130	7.8	3	3.3	3HSS2206/3HSS2208H	60	4.5
86J12156EC-1000-60 (*)	156	12	3	4.0	3HSS2206/3HSS2208H	60	5.5

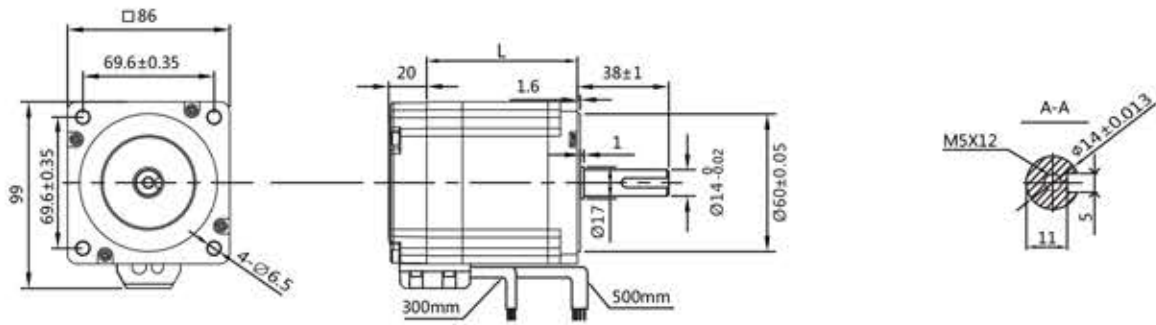

Model	Length (mm)	Holding torque (N.m)	Rated current (A)	Rotational inertia (kg-cm ²)	Matched driver	Flange (mm)	Weight (kg)
110J12135EC-1000 (*)	132.5	12	5	11.9	3HSS2208H	85	7.2
110J12160EC-1000 (*)	157.5	16	6	14.8	3HSS2208H	85	8.95
110J12190EC-1000 (*)	191.5	20	6.8	19.8	3HSS2208H	85	11.3

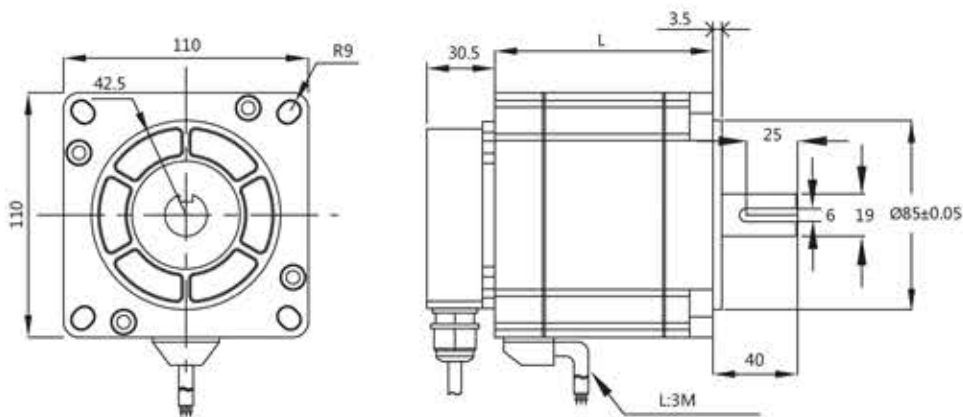

Model	Length (mm)	Holding torque (N.m)	Rated current (A)	Rotational inertia (kg-cm ²)	Matched driver	Flange (mm)	Weight (kg)
130J12205EC-2500 (*)	205	28	6.8	34.9	3HSS2208H	100	17.5
130J12225EC-2500 (*)	225	35	6.8	39.2	3HSS2208H	100	19.5

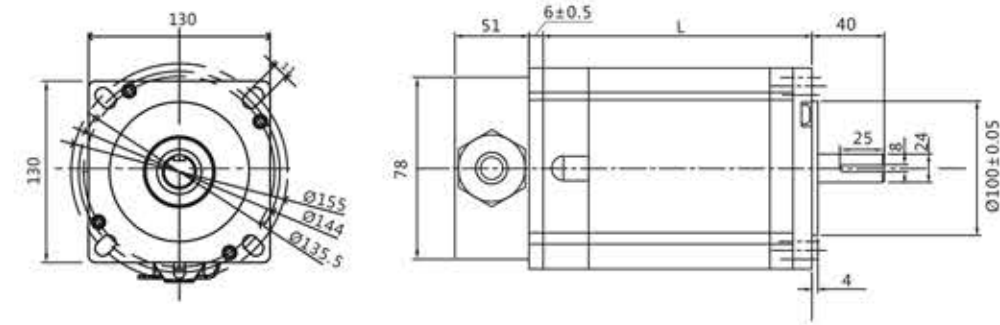

Installation dimensions of brake type closed loop motor

Model	Length (mm)	Holding torque (N.m)	Rated current (A)	Rotational inertia (kg-cm ²)	Matched driver	Flange (mm)	Weight (kg)
42J1848EC-1000-SC	48	0.48	1.5	0.08	2HSS57-42-SC	22	0.45
42J1860EC-1000-SC	60	0.7	2.5	0.11	2HSS57-42-SC	22	0.55

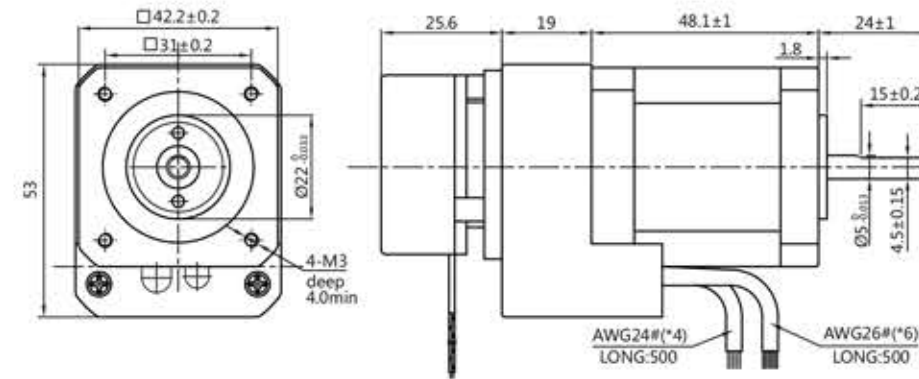

Model	Length (mm)	Holding torque (N.m)	Rated current (A)	Rotational inertia (kg-cm ²)	Matched driver	Flange (mm)	Weight (kg)
57J1854EC-1000-SCG	56	1.2	4	0.28	2HSS57-SC	38.1	1.2
57J1880EC-1000-SCG	76	2	5	0.48	2HSS57-SC	38.1	1.6

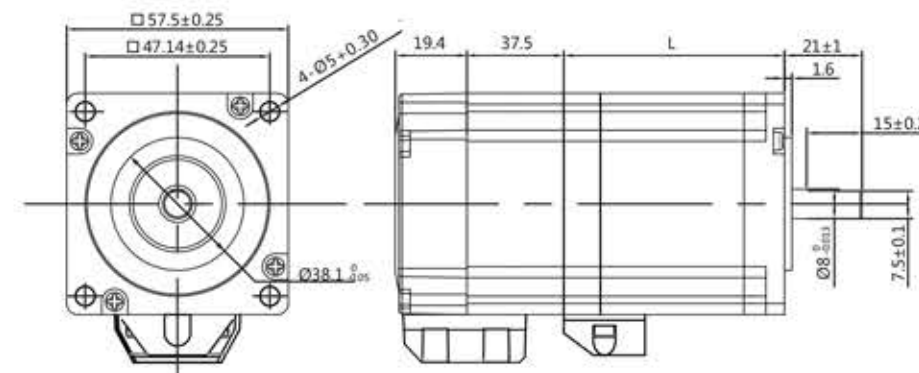

Model	Length (mm)	Holding torque (N.m)	Rated current (A)	Rotational inertia (kg·cm ²)	Matched driver	Flange (mm)	Weight (kg)
60J1856EC-1000-SCG	57	1.5	3.5	0.34	2HSS57-SC	36	1.2
60J1887EC-1000-SCG	85.6	3	5	0.69	2HSS57-SC	36	1.8
60J18100EC-1000-SCG	100	3.5	5	1.2	2HSS57-SC	36	2.0

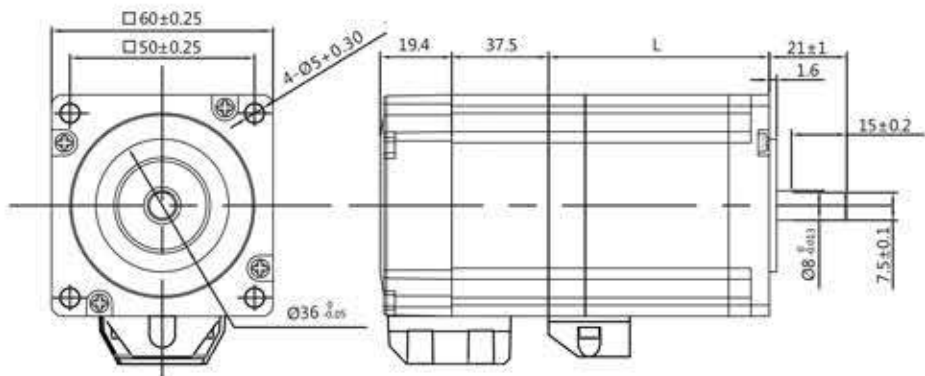

Model	Length (mm)	Holding torque (N.m)	Rated current (A)	Rotational inertia (kg·cm ²)	Matched driver	Flange (mm)	Weight (kg)
86J1880EC-1000-SCG	80	4.5	6	1.05	2HSS86H-SC	73	3.3
86J18118EC-1000-SCG	114	8.5	6	1.8	2HSS86H-SC	60/73	4.8
86J18156EC-1000-SCG	156	12.2	6	4.0	2HSS86H-SC	60/73	6.4

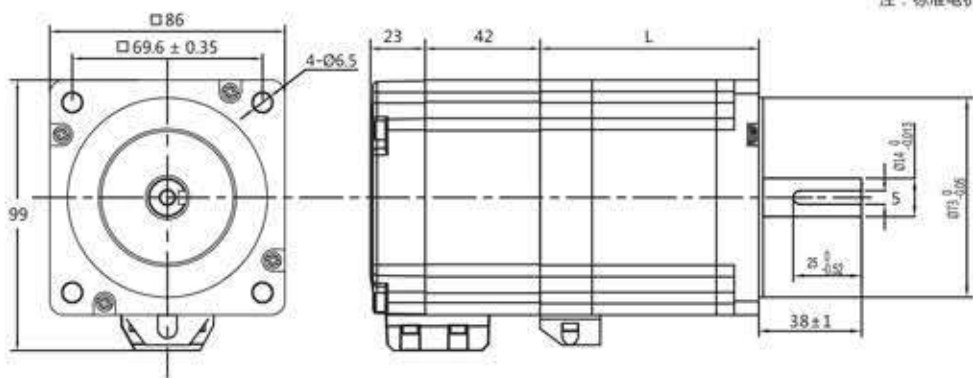

注：标准电机法兰为∅73，需∅60法兰电机要特别说明

Model	Length (mm)	Holding torque (N.m)	Rated current (A)	Rotational inertia (kg·cm ²)	Matched driver	Flange (mm)	Weight (kg)
86J12126EC-1000-60-SCG	130	7.8	3	3.3	3HSS2206H-SC	60	5.4
86J12156EC-1000-60-SCG	156	12	3	4.0	3HSS2206H-SC	60	6.3

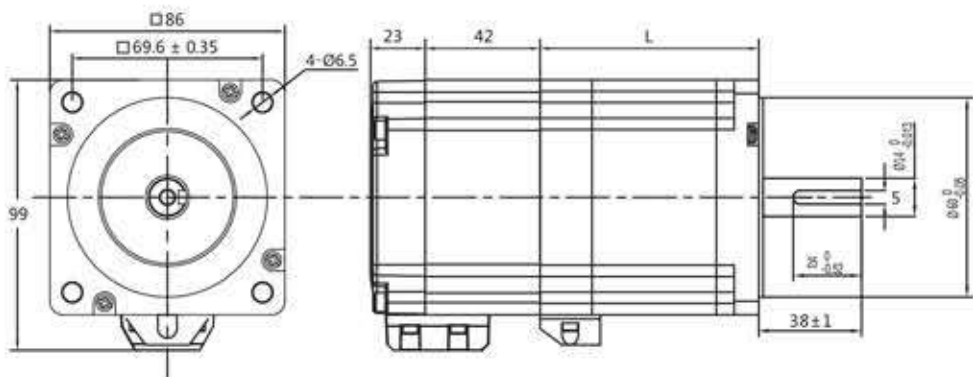

Model	Length (mm)	Holding torque (N.m)	Rated current (A)	Rotational inertia (kg·cm ²)	Matched driver	Flange (mm)	Weight (kg)
110J12135EC-1000-SC	132.5	12	4.5	11.9	3HSS2208H-SC	85	8.6
110J12160EC-1000-SC	157.5	16	6	14.8	3HSS2208H-SC	85	10.3
110J12190EC-1000-SC	191.5	20	6.8	19.8	3HSS2208H-SC	85	12.7

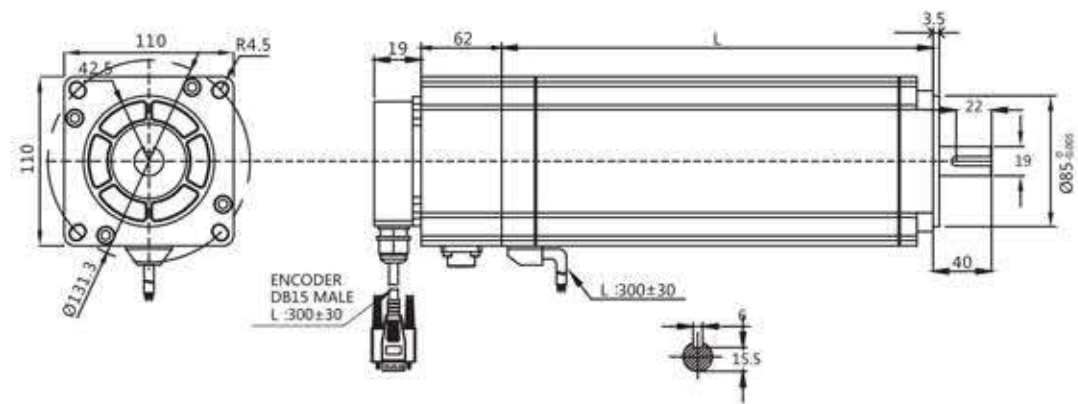

Model	Length (mm)	Holding torque (N.m)	Rated current (A)	Rotational inertia (kg·cm ²)	Matched driver	Flange (mm)	Weight (kg)
130J12205EC-2500-SC	205	28	6.8	34.9	3HSS2208H	100	19
130J12225EC-2500-SC	225	35	6.8	39.2	3HSS2208H	100	21

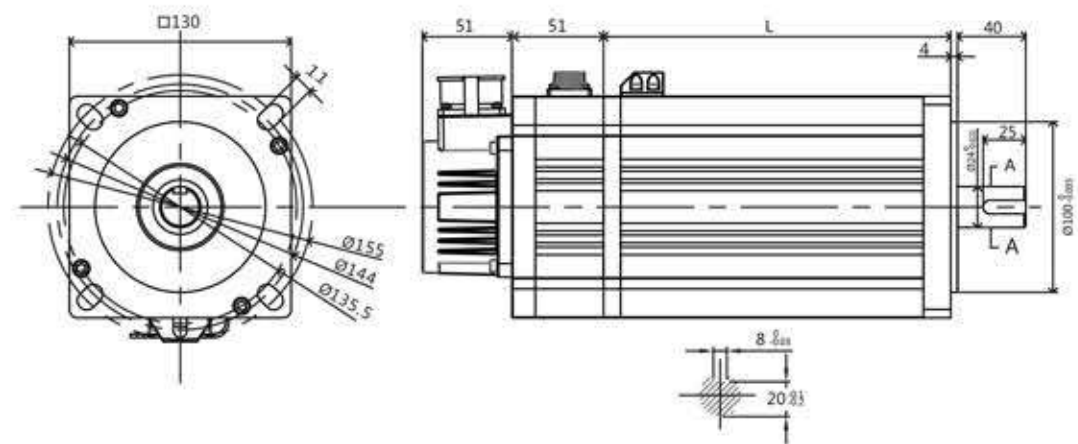

EDrive Hybrid stepper motor speed and torque chart

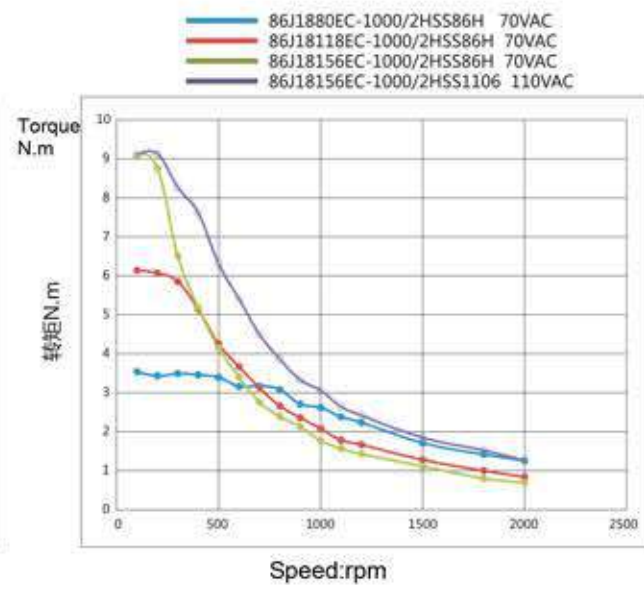
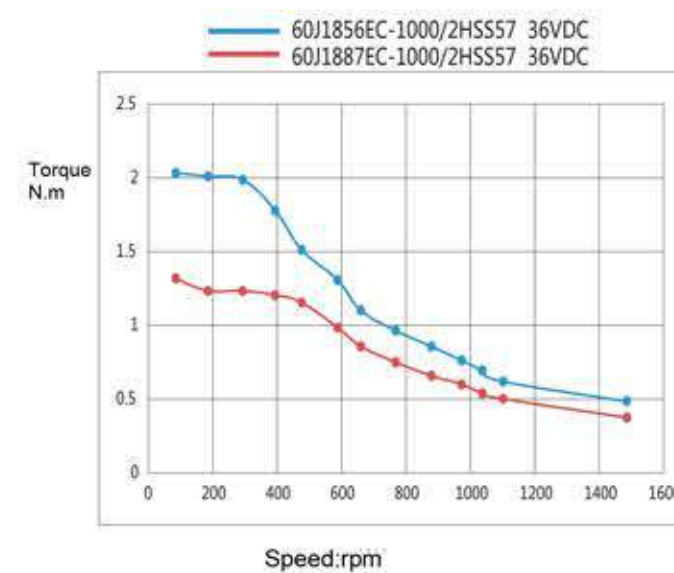
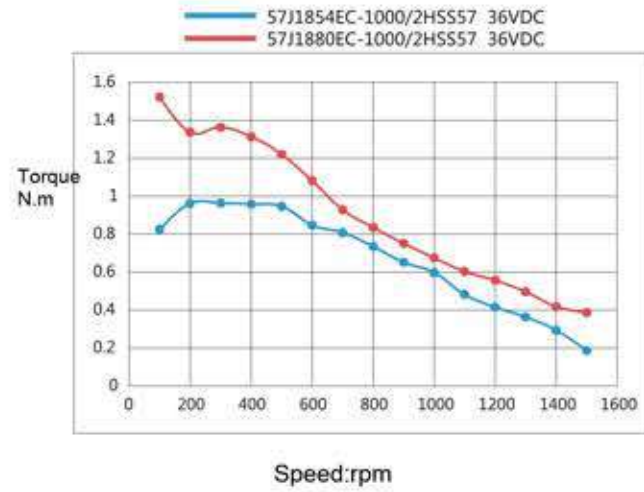
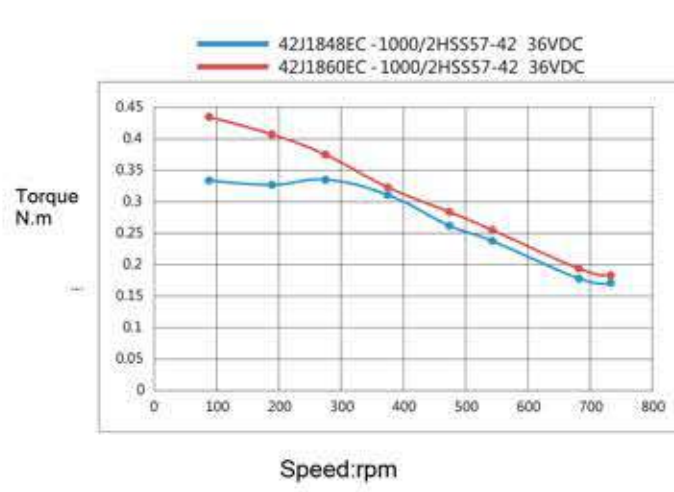

EDrive Hybrid stepper motor speed and torque chart

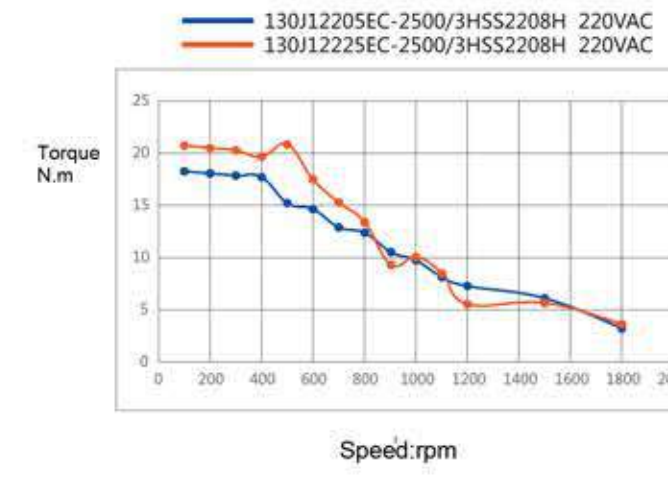
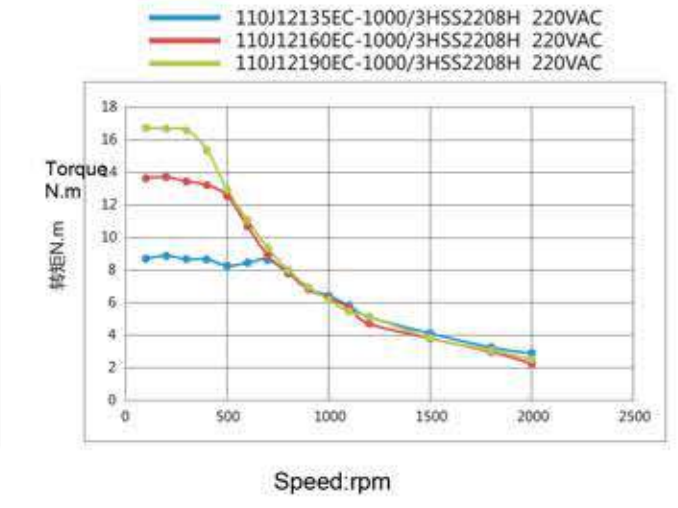
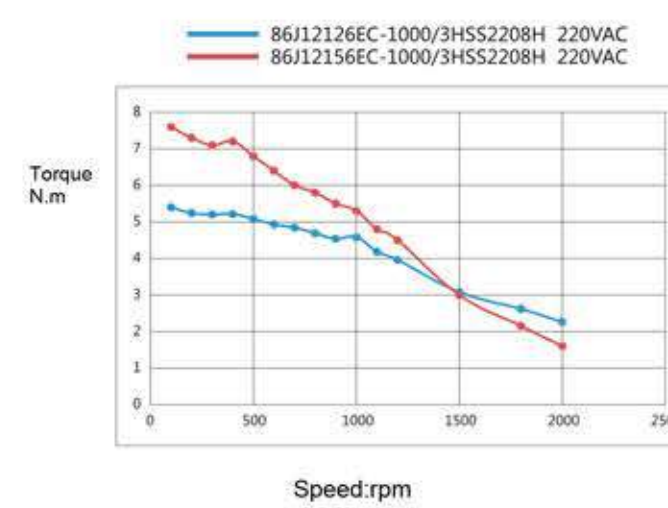

Integrated step servo motor

Name rule

iHSS **57** - **36** - **20** - **XIXIX** - **XIXIX**

1 2 3 4 5 6

1. Represents integrated stepping servo drive motor
2. Motor frame No.: 42 / 57 / 86
3. The rated DC working voltage (unit V) of motor is 24 V, which means the rated DC working voltage of the motor is 36V
4. Output torque, unit (0.1nm)10 is 1nm, 20 is 2nm
5. Input control mode blank: pulse + direction; 485: RS485 communication; CAN:CANOPEN Communication 6. Product design serial number, default to standard model. The ihss57-36-20 in the example is an integrated stepper motor with 57 stands, with a maximum power supply of 36VDC and an output torque of 2nm. It is a standard type



Series interface

Communication interface

Model	Definition of interface
iHSS42	VCC
iHSS57	TX
iHSS60	GND
iHSS86	RX
	NC

Input and output interface

Model	Definition of interface
iHSS42	
iHSS57	PUL+
	PUL-
	DIR+
	DIR-
	ENA+
	ENA-
iHSS60	PEND+
	PEND-
	ALM+
	ALM-
iHSS86	



Dial setting

iHSS series pulse + direction integrated stepping servo motor adopts 6-bit dial switch to set subdivision precision, positive and reverse direction, and effective edge of signal. Detailed description is as follows:

Pluse/rev	SW1	SW2	SW3	SW4	Pluse/rev	SW1	SW2	SW3	SW4
Default	On	On	On	On	1000	On	On	On	Off
800	Off	On	On	On	2000	Off	On	On	Off
1600	On	Off	On	On	4000	On	Off	On	Off
3200	Off	Off	On	On	5000	Off	Off	On	Off
6400	On	On	Off	On	8000	On	On	Off	Off
12800	Off	On	Off	On	10000	Off	On	Off	Off
25600	On	Off	Off	On	20000	On	Off	Off	Off
51200	Off	Off	Off	On	40000	Off	Off	Off	Off

•SW5 sets the motor direction, when it is off, the motor rotates counterclockwise (CCW), when it is on, the motor turns clockwise (CW); SW6 sets the effective pulse edge.

Installation dimensions

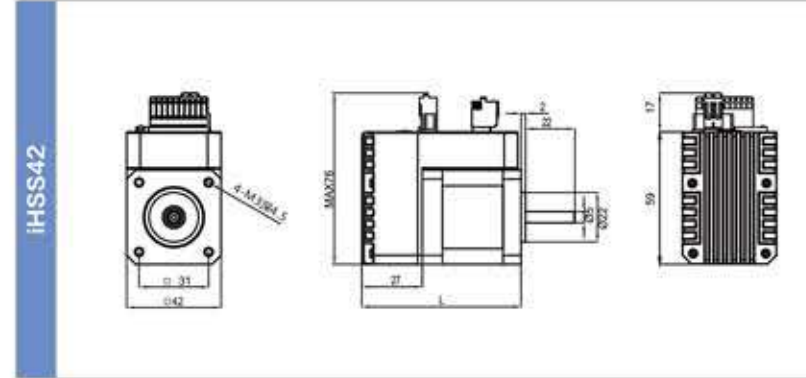

Model	Length(mm)
iHSS42-24-05-XXX	75
iHSS42-24-07-XXX	87

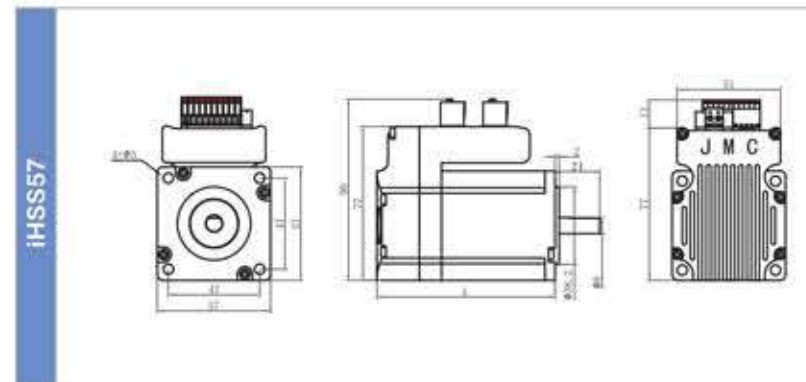

Model	length(mm)
iHSS57-36-10-XXX	88
iHSS57-36-20-XXX	108

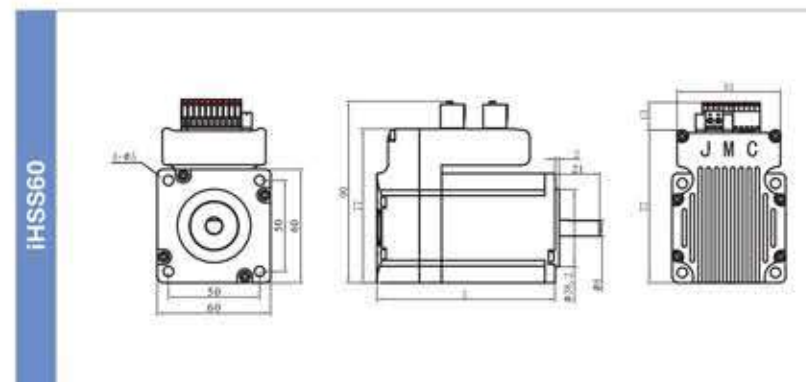

Model	Length(mm)
iHSS60-36-15-XXX	78
iHSS60-36-30-XXX	118

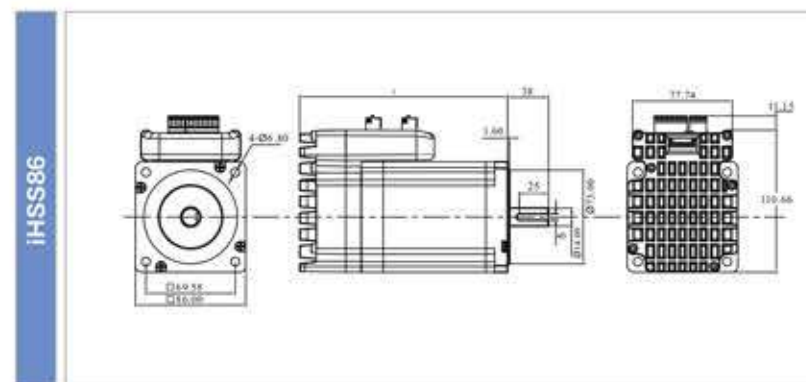

Model	Length(mm)
iHSS86-60-45-XXX	120
iHSS86-80-85-XXX	158