

FB530/630

Indicator

User manual

© EXCELL PRECISION CO., LTD. 2014. All rights reserved worldwide.

The information contained herein is the property of EXCELL PRECISION CO., LTD. and is supplied without liability for errors or omissions. No part may be reproduced or used except as authorized by contract or other written permission. The copyright and the foregoing restriction on reproduction and use extend to all media in which the information may be embodied.

Table of Contents

INSTRUCTIONS FOR USE	2
PREPARING TO USE THE SCALE	2
CHAPTER 1 INTRODUCTION	4
1-1 PRODUCTION INTRODUCTION	4
1-2 DISPLAY DESCRIPTION	5
1-3 KEYPAD FUNCTIONS DESCRIPTION	6
1-4 POWER DESCRIPTION	7
1-5 ERROR MESSAGES	8
CHAPTER 2 GENERAL OPERATION DESCRIPTION	9
2-1 BACKLIGHT FUNCTION	9
2-2 WEIGHING MODE	9
2-2-1 Units Selection	9
2-2-2 Check Weighing Mode	9
2-2-3 Totalizing	11
2-2-4 Zero Function	12
2-2-5 Tare Function	12
2-2-6 Printing Function (option)	14
2-3 COUNTING FUNCTION	16
2-3-1 Sampling	16
2-3-2 Check Weighing	16
2-3-3 Totalizing	16
CHAPTER 3 GENERAL FUNCTION SETTING	17
3-1 F4 ⇒ CHECK WEIGHING CONFIGURATIONS	18
3-2 F5 ⇒ RS-232 INTERFACE AND MINI PRINTER OUTPUT SETTING (OPTION)	19
3-3 F6 ⇒ EXIT SETTING MODE	27
3-4 F7 ⇒ INTERNAL VALUE DISPLAY MODE	27
3-5 F10 ⇒ G VALUE CALIBRATION	28
3-6 F11 ⇒ ID CODE SETTING	29
3-7 F12 ⇒ PRINT KEY () FUNCTION SETTING	30
3-8 F14 ⇒ PRINTING ORDERS WHEN F5 IS SET AS	31
APPENDIX 1 OPTIONAL FUNCTION DESCRIPTION	34
APPENDIX 2 LOAD CELL PIN DESCRIPTION	35
APPENDIX 3 PRINTER INSTALLATION	36
APPENDIX 4 LOAD HOOK INSTALLATION	37
APPENDIX 5 7-SEGMENT DISPLAY CHARACTERS	38

Thank for your purchasing of our EXCELL Weighing Scale. To guide you to use our product correctly, please read this User Manual carefully to extend the life of machine and to avoid error.

Instructions for Use

1. Please keep scale in a cool and dry place. Do not store under high temperatures.
2. Please keep the scale clean and free from insect infestation.
3. Avoid impacting with other items or overloaded with excessively heavy weights (The load must not exceed the maximum capacity of the scale).
4. If the scale is not going to be used for some time, please clean it and store it in a plastic bag in dry condition. A desiccant sachet may be included to prevent moisture from building up.
5. Do not mix different types of dry battery or mix used dry batteries with new dry batteries.
6. Please operate or charge the scale in an open area. Do not squeeze the power cord to avoid wire on fire.
7. Operating temperature: $-10^{\circ}\text{C} \sim +40^{\circ}\text{C}$
8. Any suggestion is warmly welcome.

Preparing to Use the Scale

1. Locate the scale on a firm level surface free from vibrations for accurate weight readings. Adjust the four leveling feet to centre the leveling bubble on the scale.
2. Avoid hot sunshine directly on the scale or near the exhaust port of ventilating system.
3. Please use a separate power source plug, to avoid the disturbance of other electric appliance.
4. There should be no weight on the scale when power is turned on.
5. Commodity should be placed at the centre of platter when being weighed, and its size should not exceed the dimension of the platter.
6. Please warm the scale 15 ~ 20 minutes before using.
7. Please note that when  symbol appears on the screen, the scale needs to be charged.
8. Introduction of Storage Battery

Due to the storage battery adopt the advanced free-maintaining technique, customers need not to replenish electrolyte.

The scale should be recharged every 3 months to prevent failure of the internal rechargeable battery.

1. The battery should be charged for 8~10 hours.
2. The temperature of battery should below 45°C.

Maintaining

1. Please do not discharge with over-current when using the battery. Please charge the battery after discharging current.
2. Please take down the battery when the scale is not used for a long time or break the connection of cathode.
3. Do not short the battery terminals to check whether there is current. Please check whether the connection point is firm to guarantee good connection.
4. The battery should be replaced by specialized person. **No reverse-battery or the product will be damaged.**
 - a) Anode of battery should be connected with Anode of product battery (usually red cable)
 - b) Cathode of battery should be connected with Cathode of product battery (usually brown cable or black cable)
 - c) See the picture following

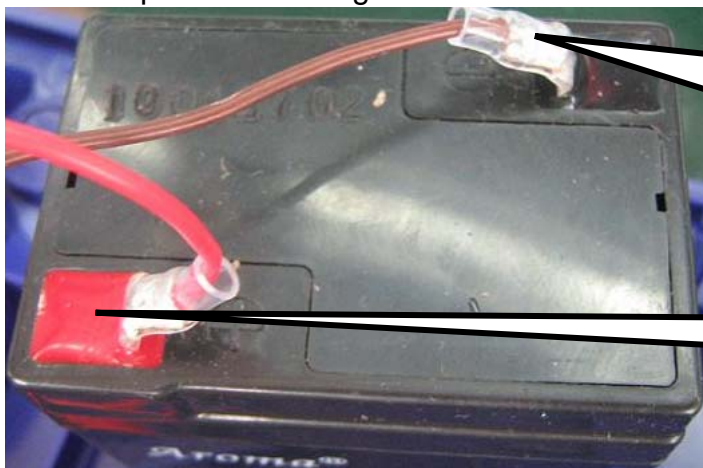

Brown cable(or black cable)
connected with Anode of
battery

Red cable connected with
Cathode of battery

Safety warnings

1. The electrolyte of battery is caustic which causes metal, cotton, etc to corrode.
2. The hydrogen will be resolved when using or charging the battery and it will cause explosion when approaches fire.



No burning



Caution Corrosion



Warning explosion



Children faraway



Chapter 1 Introduction

1-1 Production Introduction

1. High performance A/D converter

- 0.3 μ V/D high sensitivity
- zero point adjustable range -2mV~ +5mV
- Sampling speed 15 times/second
- use range -4mV ~ +30mV
- non-linear scale 0.01% full scale
- load cell stimulate power source 5V DC \pm 2% 100mA

2. According to different resolution to do linearity calibration

- Ordinary resolution models (below 10000)
Do specification calibration first then do weight calibration
- High resolution models (10000~30000)
Do linearity calibration first → specification calibration → weight calibration at last

3. EPSON(M-150II)16L mini printer output (option)

4. One group of RS232 (option)

5.4 HOLD functions (contain animal scale HOLD function)

6. LCD display

7. Adapter and rechargeable battery

8. Blackout automatically in order to keep the system stable

(When battery voltage is lower than system voltage, the system will cut the power off automatically to ensure its stable and accuracy.)

9. LED BACKLIGHT

10. Appearance size: 276 X 172 X 153mm (L x W x H)(no back display)

276 X 202 X 153mm (L x W x H)(with backdisplay)



1-2 Display Description

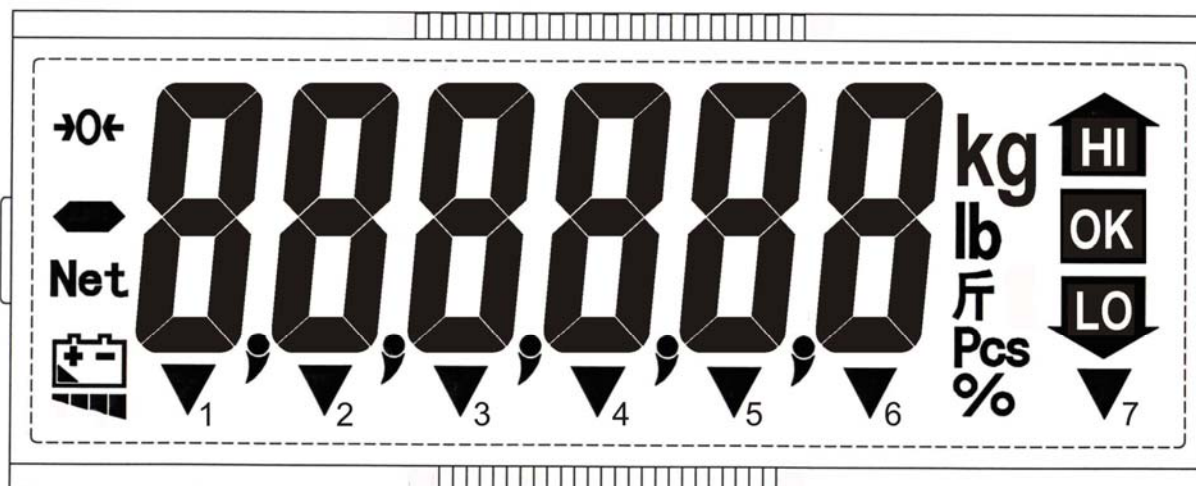















HI	:	High limit value
OK	:	OK value (The value between HI and LO limit value)
LO	:	Low limit value
→o←	:	“Zero” indication
Net	:	“Net weight” indication
	:	“Low battery power” indication
▼1	:	“Stable” indication
▼2	:	“Pre-tare mode” indication
▼3	:	“Accumulation mode” indication
▼4	:	PRINTER READY(mini printer connected)
▼5	:	“Samples insufficient” indication
▼6	:	“Unit weight insufficient” indication
▼7	:	“Viss” unit (Burma unit)
kg	:	“kg” unit
lb	:	“lb” unit
斤	:	No function
Pcs	:	Counting mode
%	:	Percent indication

Changes of “Range” indication mode

The indicator with 2-segment specification:

▼6 is Range 1 ▼5 is Range 2

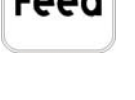
1-3 Keypad Functions Description

-  : Press this key to select the required unit from the preset units.
-  : Press this key to preset the weight and quantity.
-  : Press this key to accumulate the weight value or others.
-  : Press this key to tare (deduct the container weight)
-  : Press this key to preset tare value.
-  : Press this key to recall the totalization value, preset value and pre-tare value.
-  : Press this key to clear the totalization value, preset value and pre-tare value.
-  : Press this key to zero the scale.
-  : Press this key to confirm.
-  : Press this key to enable/disable backlight.
-  : Press this key to go into counting mode.
-  : Press this key to sample.
-  : Press this key to print.
-  : Press this key to input number 0~9.
-  : Press this key to feed the paper.



1-4 Power Description

Power Selection

1. 6 V / 4 Ah Rechargeable battery
2. 110 V / 220 V $\pm 15\%$ AC

Recharge Voltage





1. AC 110 V +10% , -15%
2. AC 220 V +10% , -15%

Power Consumption

	State	Consumption	Time
ex. With a 350 Ω Load Cell	No printer indicator+ L/C + front display backlight +back display backlight +printer	Less than 55 mA	70 hours
	With printer indicator+ L/C + front display backlight + back display backlight + printer	Less than 350 mA	10 hours
No printer	indicator+ L/C + no backlight	26 mA	180 hours
	indicator+ L/C + front display backlight	32 mA	140 hours
	indicator+ L/C + front display backlight + back display backlight	40 mA	110 hours
Single RS-232		20 mA	

Low Power Alarm

Please note when the () symbol keeps flashing on the left down corner of the display, the batteries should be recharged.

-  The scale will turn off automatically after a few hours when the low battery warning symbol shows up. The scale must be fully recharged, before operating again.
-  Please recharge at once when the symbol  shows in order to keep the weight accuracy.
-  If there is mini printer, do not take down the storage battery (only leave AC battery) , or the scale will unstable.

Memory Cell

-  When AC battery is cut off and Lead acid battery voltage is lower than 3V, the data in RTC IC can maintain for 24 hours.

1-5 Error Messages

- OL** ⇒ Weight exceed 9d of maximum capacity. (d=division)
- E 1** ⇒ Zero value after power on is over +10% FS.
- E 2** ⇒ Zero value after power on is less than -10% FS.
- E 4** ⇒ Unstable zero return, unstable over 10 sec. Press  to leave E4.
- E 6** ⇒ Zero is too high when calibrating. (over internal value 350,000)
- E 7** ⇒ Zero is too low when calibrating. (under internal value 80,000)
- E 10** ⇒ The scale is not in level status.(only available with level detector equipment.)
- ⇒ If the negative weight is over 20 divisions and there is no T or PT, the display shows "-----"



Chapter 2 General Operation Description

2-1 Backlight Function



Press key to select the display backlight mode:

BL. Auto ⇒ “Auto Backlight” mode. When the weight is over 10d or any key is pressed, the display backlight will be switched on. When the weight returns to zero (the weight on platform is less than 10d), the display backlight will switch off after 10 seconds.

BL. on ⇒ Display backlight is on all the time.

BL. off ⇒ Display backlight is off.

2-2 Weighing Mode

2-2-1 Units Selection



1. After indicator is turned on, use **UNITS** key to select a unit from kg, lb, tael or viss, as the screen indicated.
2. The selected unit will be memorized when you turn the indicator off. And the memorized unit will appear after you turn on the indicator next time.

2-2-2 Check Weighing Mode

1. Preset “High limit”, “Low limit” and “Beeper value” operation

Use and key to preset values.

For example:

Preset “Low limit” (Low limit >10d) *e.g. Low limit = 20 kg*

Press	key	the display shows	0 - - . - - L
Press	key 1 time	the display shows	0 0 - . - - L
Press	key 2 times	the display shows	0 2 - . - - L
Press	key 4 times	the display shows	0 2 0.00 0

Preset “High limit” (High limit ≥ Low limit) *e.g. High limit = 25 kg*

Press	key 1 time	the display shows	0 - - . - - H
Press	key 1 time	the display shows	0 0 - . - - H
Press	key 2 times	the display shows	0 2 - . - - H
Press	key 1 time	the display shows	0 2 0 - - H
Press	key 5 times	the display shows	0 2 5 - - H
Press	key 3 times	the display shows	0 2 5.00 0

Preset "Beeper value" (Refer to **Note**) e.g. *Beeper value = 22*

Press		key 1 time	the display shows	$\geq 0 \leq - b$
Press		key 2 times	the display shows	$\geq 2 \leq - b$
Press		key 1 time	the display shows	$2 \geq 0 \leq b$
Press		key 2 times	the display shows	$2 \geq 2 \leq b$
Press		key 1 times	the display shows	0.000

 **Preset Single point (preset low limit only):**

After "preset low limit" procedures is completed and the display shows $\geq 0 \leq - - . - -$
HI, then press  key again, the display shows 0.000. This means that the
 "preset single point" procedure is completed.

NOTE

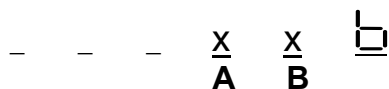

- A** Setting for the status that LCD is on and the beeper beep:
 - 0 = when stable, the beeper beeps and LCD is on.
 - 1 = when stable, the beeper beeps; whether stable or not, LCD is on.
 - 2 = whether stable or not, the beeper beeps and LCD is on.
 - 3 = open warning device: when the weight is higher than HI value and the weight is stable, LCD is on and Relay Card open.
- B** Setting for the beep status:
 - 0 = No beep
 - 1 = OK (when the weight is over Low Limit & under or equal to High Limit.), the beeper beeps.
 - 2 = When the weight is under or equal to Low Limit & over High Limit, the beeper beeps.

 **Under Status in Preset Low Limit (preset single point only)**
 The BEEP, LCD mode should be fixed as follows:

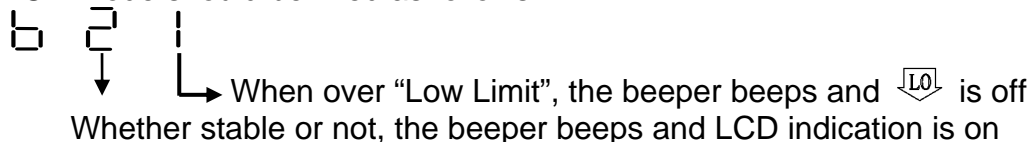

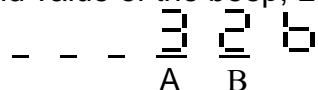

 **Warning device setting**

Set HI value and value of the beep, LCD mode should be fixed as follows:





When the weight equals to HI value, Relay Card open and the weight is accumulated.
 Press  key to dismiss the warning sound and the range of accumulated weight is [000.000]~[999999].

☰ Clear warning accumulation



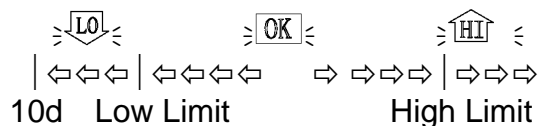

- ◆ Press  key first and then press  key to clear all accumulated data.
- ◆ Accumulated data is cleared automatically under in following conditions
 - a. when shift among weight mode, counting mode and warning accumulation mode.
 - b. when shift the units
 - c. turn off the scale

☰ LCD indication:









- ◆ To exit preset mode, please press  key.

2. Recall Check-weighing Values

- Press  key then press  key ⇒ Recall “Low limit value”
- Then press  key again ⇒ Recall “High limit value”
- Then press  key again ⇒ Recall “Beeper value”
- Then press  key again ⇒ Back to the beginning

3. Clearing Check-weighing Values

- Press  key then press  key, and then press  key ⇒ Recall “Low limit value”
- Then press  key again ⇒ Clear “High limit value” and “Beeper value”
- Press  key then press  key 6 times continuously ⇒ Clear all values.

2-2-3 Totalizing

1. Weight Totalizing

Place goods on the platter, after stable and press  key to save the weight value. Then the display shows the total number of additions and the totalized weight value. And the (M+) indication “▼” will flash on the display. The indicator will recover to show the weight value of the goods on the platter after 3 seconds and the (M+) indication “▼” is on.



☰ The indicator allows the next totalizing operation, even when the weight value does not return back to zero. The  key is functional, when the weight value changes by more than 10d. The indicator will save the totalized weight value after the weight is stable.

☰ The indicator can totalize positive or negative weight but can't do both at the same time. The totalized weight store must be reset to zero before it is possible to select positive or negative totalizing mode.

 The totalizing function can be used up to a maximum of 9999 times before it must be reset. The totalizing display is limited to 6 digits maximum.

 When totalizing, RS-232 and Mini Printer will also output. (Refer to F5 setting)

2. Clear Totalized Weight Values

- ◆ Press  then  key to clear all totalized weight values.
- ◆ When changing between weighing and counting mode, or selecting weighing unit, the indicator will automatically clear all the totalized weight values.
- ◆ The indicators will automatically clear all the totalized weight values after turning on.

3. Recall Totalized Weight Values

Press  key to display the total number of additions and the totalized weight value. And the (M+) indication “▼” will flash on the display. The indicator will return to the weighing mode after 3 seconds.

 The indicator will not display the negative sign “-” for negative totalized weight values when recalling a totalized weight value, but when printing, the negative sign “-” will be printed out (transmitted serially) for each negative weight and negative totalized weight.

2-2-4 Zero Function

Press  key to re-zero the display with no load on the platter. When zero is set, the (→0←) symbol will be displayed.



2-2-5 Tare Function



1. When the weight of the container is unknown ()

- ① Place the container on the platter, after stable and press  key, the weight value returns to zero and net indication (**Net**) is on.
- ② Place goods into the container, then the indicator shows the net weight of goods.
- ③ Clear tare value

When removing the container and goods, the display shows the negative weight value of the container. Then press  key to clear tare value. The indicator returns to zero and net indication (**Net**) is on.

- ④ Recall tare value



Press  then  key ⇒ the display shows tare value

 Multiple tare operation ⇒ Users can continuously increase or decrease the tare value by pressing the  key.

 The total tare value (tare value + pre-set tare value) can equal the full capacity of the indicator.



2. When the weight of the container is known ()

❶ Press  key and the display shows $\geq 0 \leq - . - - P$.

Use  and  keys to input weight value of the container. After finishing the procedures, the net indication (**Net**) and pretare indication “▼” is on.



❷ Place goods into the container, then the indicator shows the net weight of goods.

❸ Clear pretare value

Press  then  key, and then press  key to clear pretare value.

When the indicator returns to zero, net indication (**Net**) and pretare indication “▼” off.



❹ Recall pretare value

Press  then  key \Rightarrow the display shows pretare value

 In Tare mode, the Preset tare function is disabled.

 The indicators with two weighing ranges can NOT pre-set the tare value larger than the first weighing range. For example: a 30 kg indicator is set by two weighing ranges. The first range is 0 to 15 kg, and the second range is 15 to 30 kg. The pre-set tare value can not be larger than 15 kg.

2-2-6 Printing Function (option)

F5	Function	Press  key	Press  key	Press  key twice after zeroing
r n p 0	RS-232 closed	RS-232 and Printer do not transmit	RS-232 and Printer do not transmit	RS-232 and Printer do not transmit. Totalized values do not clear off
	Printer closed			
r n p 1	When weight is stable, RS232 transmits automatically (when re-zeroed, RS-232 transmits next time after stable.)	RS-232 and Printer do not transmit	RS-232 and Printer do not transmit	RS-232 and Printer do not transmit. Totalized values do not clear off
	Printer closed			
r n p 2	RS-232 continuously transmits	RS-232 transmits Printer does not transmit	RS-232 transmits Printer does not transmit	RS-232 transmits Printer does not transmit Totalized values do not clear off
	Printer closed			
r n p 3	RS-232 totalizes and transmits	RS-232 transmits when weight changes by over $\pm 10d$	RS-232 transmits when weight changes by over $\pm 10d$	RS-232 prints TOTAL and clears totalized values
	Printer totalizes and transmits	Printer transmits when weight changes by over $\pm 10d$	Printer transmits when weight changes by over $\pm 10d$	Printer prints TOTAL and clears totalized values
r n p 4	RS-232 totalizes and transmits	RS-232 transmits when weight changes by over $\pm 10d$	RS-232 transmits when weight changes by over $\pm 10d$	RS-232 prints TOTAL and clears totalized values
	Printer totalizes and transmits	Printer transmits when weight changes by over $\pm 10d$	Printer transmits when weight changes by over $\pm 10d$	Printer prints TOTAL and clears totalized values
r n p 5	When weight is stable, RS-232 totalizes and transmits automatically (when re-zeroed, RS-232 transmits next time after stable and. weight changes by over +10d)	RS-232 does not transmit	RS-232 does not transmit	RS-232 prints TOTAL and clears totalized values
	When weight is stable, Printer totalizes and transmits automatically (when re-zeroed, Printer transmits next time after stable and. weight changes by over +10d)	Printer does not transmit	Printer does not transmit	Printer prints TOTAL and clears totalized values



r n p 6	RS-232 totalizes and transmits	RS-232 transmits when weight changes by over $\pm 10d$	RS-232 transmits when weight changes by over $\pm 10d$	Printer prints TOTAL and clears totalized values
	Printer totalizes and transmits	Printer transmits when weight changes by over $\pm 10d$	Printer transmits when weight changes by over $\pm 10d$	Printer prints TOTAL and clears totalized values
r n p 7	RS-232 totalizes and transmits	RS-232 transmits when weight changes by over $\pm 10d$	RS-232 transmits when weight changes by over $\pm 10d$	Printer prints TOTAL and clears totalized values
	Printer totalizes and transmits	Printer transmits when weight changes by over $\pm 10d$	Printer transmits when weight changes by over $\pm 10d$	Printer prints TOTAL and clears totalized values
r n p 8	After RS-232 is stable , press  key to transmit	RS-232 does not transmit	RS-232 transmits when weight changes by over $\pm 10d$	RS-232 and Printer do not transmit. Totalized values do not clear off
	Printer closed	Printer does not transmit	Printer does not transmit	

2-3 Counting Function

2-3-1 Sampling

① Press  key to select sample quantity from 10, 20, 50, 100 and the display shows 10, 20, 50, 100 accordingly.

② Select sample quantity and then place samples on the platter, and then press  key, the display shows “SAMPLE”.

After stable, the scale enters into counting mode and the display shows sample quantity.

◆ Sample Too Small () ⇒ Sample is less than 20 divisions.

◆ Unit Weight Too Small () ⇒ Unit weight is less than 0.2 division.
(0.1 d for Brazil regulation)



When sampling, the above two symbols indications are on. Under such conditions, the scale can still work, but may result in lower count precision.



When using 2-segment weighing mode, the above two symbol indications change to Range 2 and Range 1 and the two symbol indications are off.



2-3-2 Check Weighing

Refer to the operation of check weighing in weighing function.

2-3-3 Totalizing

Refer to the operation of totalizing in weighing function.

Chapter 3 General Function Setting

- ◆ Switch on the scale. While the scale is counting down to zero, press and hold  key until the display shows the software program version number **020 18**. Release the  key, the scale enters into the configuration setting mode and **F 0** is showed on the display.

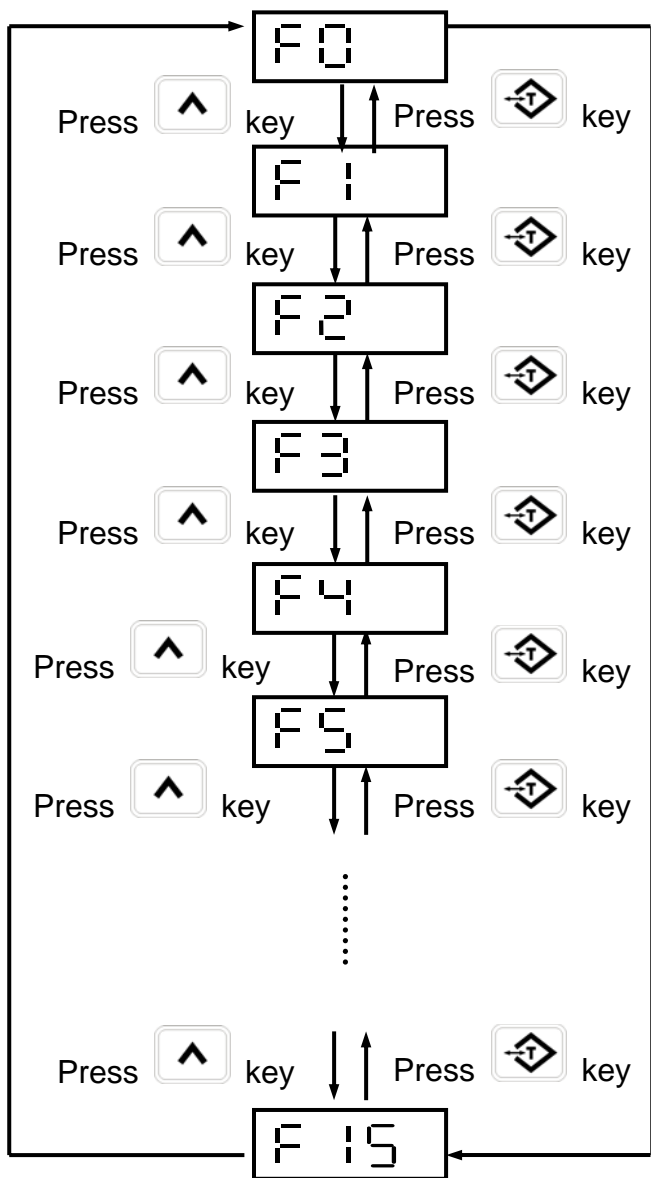

- F 0 ⇒ Reserved
- F 1 ⇒ Reserved
- F 2 ⇒ Reserved
- F 3 ⇒ Reserved
- F 4 ⇒ Check-weighing configurations
- F 5 ⇒ RS-232 Interface output Setting
- F 6 ⇒ Exit setting mode
- F 7 ⇒ Internal value display mode
- F 8 ⇒ Reserved
- F 9 ⇒ Reserved
- F 10 ⇒ G Value adjustment
- F 11 ⇒ ID code setting
- F 12 ⇒ Print key () function setting
- F 13 ⇒ Reserved
- F 14 ⇒ Printing orders when F5 is set as **r n P 6** or **r n P 7**
- F 15 ⇒ Reserved



3-1 F4 ⇒ Check Weighing Configurations

◆ If hold mode is set, accessing to F4 is denied.

Use or key to select F4 function ⇒ the display shows F4

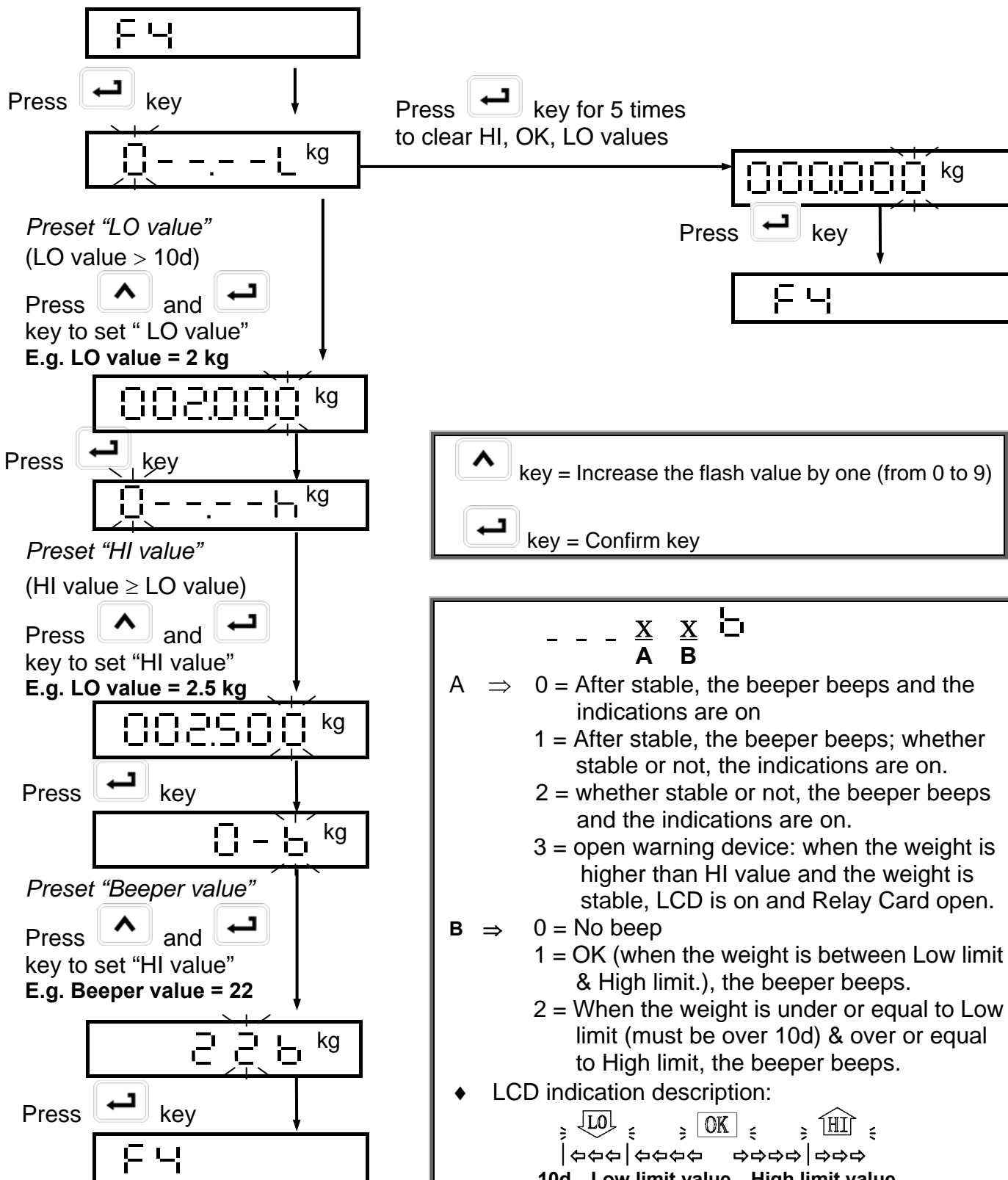

key = Increase the flash value by one (from 0 to 9)

key = Confirm key

- - - X X b
 A B

A ⇒ 0 = After stable, the beeper beeps and the indications are on
 1 = After stable, the beeper beeps; whether stable or not, the indications are on.
 2 = whether stable or not, the beeper beeps and the indications are on.
 3 = open warning device: when the weight is higher than HI value and the weight is stable, LCD is on and Relay Card open.

B ⇒ 0 = No beep
 1 = OK (when the weight is between Low limit & High limit.), the beeper beeps.
 2 = When the weight is under or equal to Low limit (must be over 10d) & over or equal to High limit, the beeper beeps.

◆ LCD indication description:

|←←←|←←←| ↔↔↔↔|↔↔↔|
 10d Low limit value High limit value

3-2 F5 ⇒ RS-232 Interface and Mini Printer Output Setting (option)

- ◆ The mini printer interface default setting is 9600, N, 8, 1, and it also contains the RTC setting.
- ◆ Our company provides the printing title editing software. If you would like this service, please contact your local dealer.

Use  or  key to select F5 function ⇒ the display shows F5

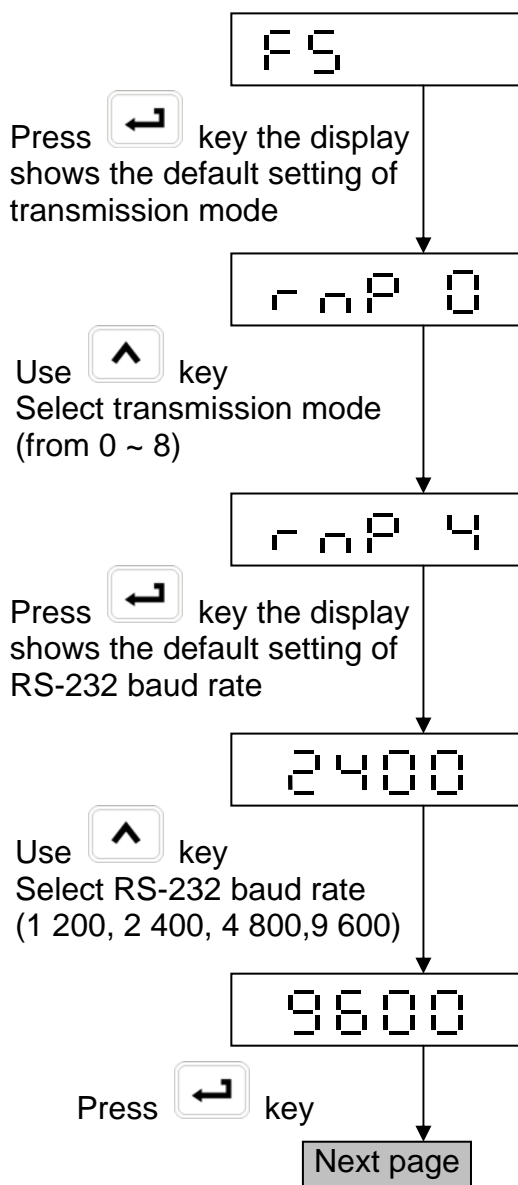

 key = Increase the flash value by one (from 0~8) or selecting baud rate from 1 200, 2 400, 4 800 and 9 600(default setting)

 key =Confirm key

r n P 0 ⇒ No transmission

r n P 1 ⇒ Stable transmission *

r n P 2 ⇒ Continuous transmission *

r n P 3 ⇒ Press  key to transmit in simple *^m

r n P 4 ⇒ Press  key to transmit in complete mode. *^m



r n P 5 ⇒ Stable transmission in totalizing mode.
The format is as same as r n P 3 *^m

r n P 6 ⇒ Refer to F14*^m

r n P 7 ⇒ Refer to F14*^m

r n P 8 ⇒ Press  key to transmit. *^m
(The format is as same as r n P 1 and r n P 2)

r n P 9 ⇒ Continuous transmission, specific format*

r n P 10 ⇒  or  transmit specific format*

* : RS-232 is open
m : mini printer is open

Brazil approval models: if the unit weight is less than 0.1d, RS232 will shut down

Connect to Mini Printer before continue

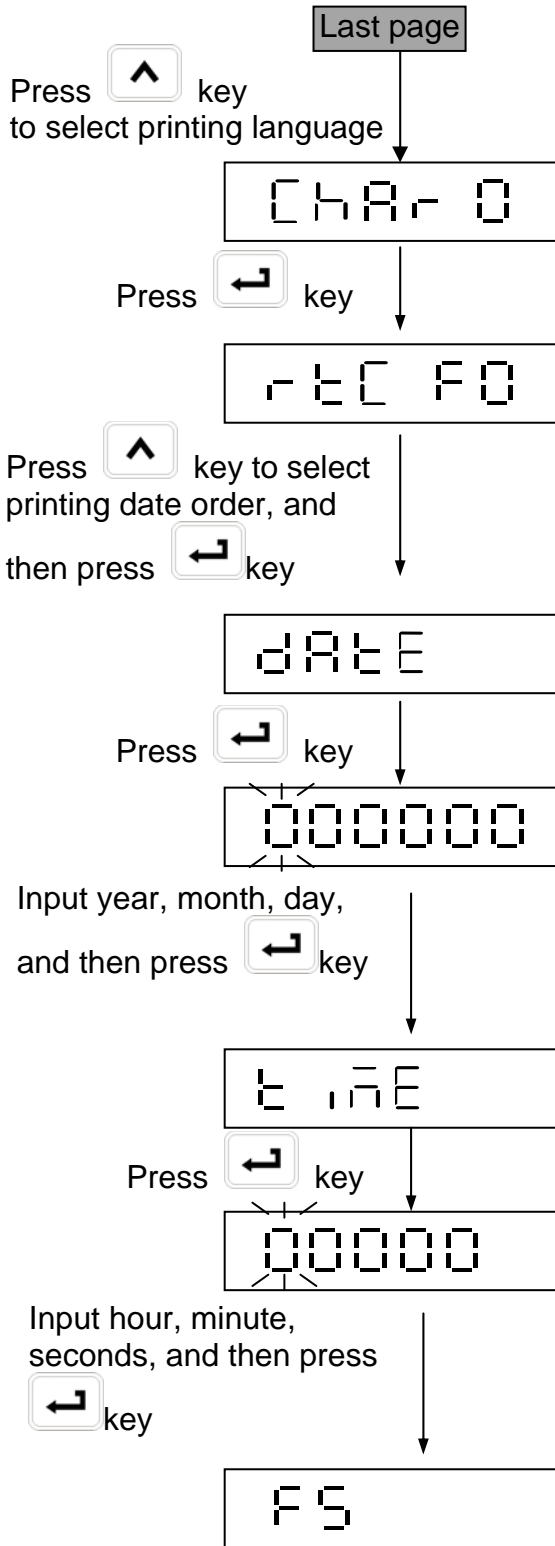

Mini Printer Printing Languages :

CHAR 0	Iranian
CHAR 1	English
CHAR 2	Traditional Chinese
CHAR 3	Simplified Chinese

Date Printing Order Setting

r t C F 0	YY MM DD
r t C F 1	MM DD YY
r t C F 2	DD MM YY

Default setting: YY MM DD

RS-232 Interface Format

I . Mode: UART Signal of EIA-RS0232 C

II . Format :

1. Baud rate : 1 200, 2 400, 4 800, 9 600 bits/second
2. Data bits : 8 bits
3. Parity bit : None
4. Stop bits : 1 bit
5. Code : ASCII (Exchange code of American standard)

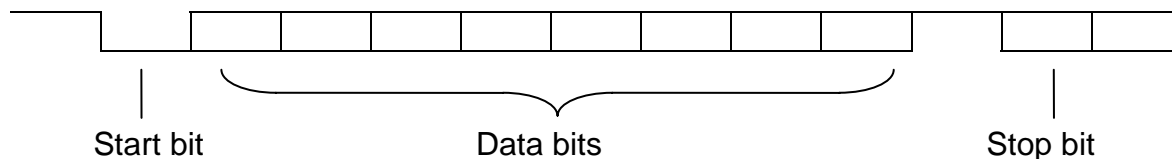

RS-232 Data Format

Stable transmission ($\overline{\text{r n P 1}}$), Continuous transmission ($\overline{\text{r n P 2}}$),

Press  key to transmit ($\overline{\text{r n P 8}}$)

(1). gram as weight unit

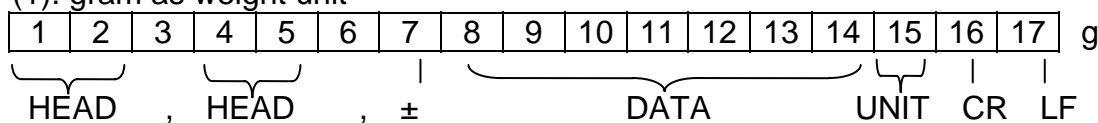

(2). kg or lb as weight unit

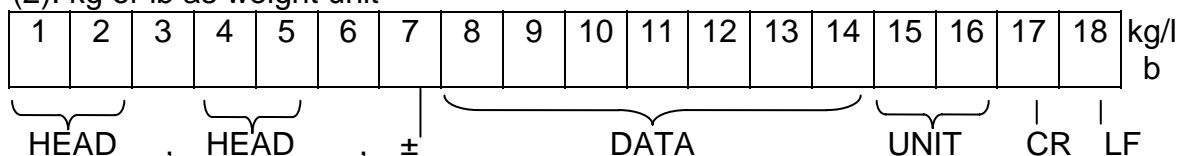

(3). lb.oz as weight unit

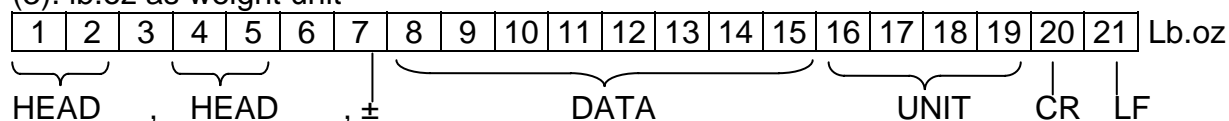

(4). HK tael as weight unit

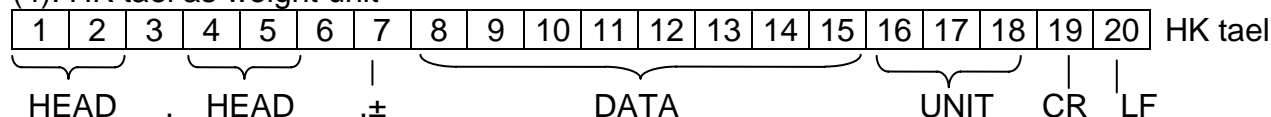

(5). viss as weight unit

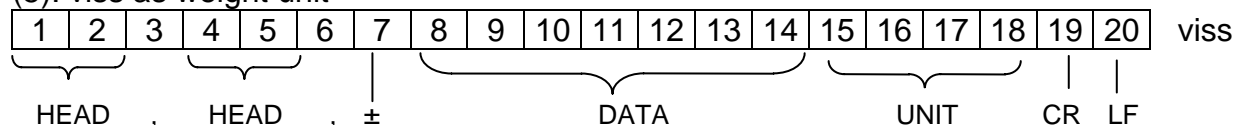



HEAD1 (2 BYTES)		HEAD2 (2 BYTES)	
OL	- Overload , Under load	TR	- TARE Mode
ST	- Display is Stable	NT	- NET Mode
US	- Display is Unstable	GS	- GROSS Mode

DATA (7 or 8 BYTE)

2B (HEX) = “ + ” (PLUS)

2D (HEX) = “ - ” (MINUS)

2E (HEX) = “ . ” (DECIMAL POINT)

UNIT (2 、 3 or 4 BYTE)

kg = 6B (HEX) ; 67 (HEX)

lb = 6C (HEX) ; 62 (HEX)

tl.T = 74 (HEX) ; 6C (HEX) ; 2E (HEX) ; 54 (HEX)

hkg = 68 (HEX) ; 67 (HEX)

viss = 76 (HEX) ; 69 (HEX) ; 73 (HEX) ; 73 (HEX)

Transmission examples:

Data format for RS-232 continuous transmission are as below:

1. The gross weight (+0.876 kg) shows as below, after stable: (no tare or pre-tare mode)

S	T	,	G	S	,	+			0	.	8	7	6	k	g	0D	0A
HEAD1			HEAD2			DATA								UNIT	C	LF	

2. The net weight (-1.568 lb) shows as below without weight stability: (tare or pre-tare mode)

U	S	,	N	T	,	-			1	.	5	6	8	l	b	0D	0A
HEAD1			HEAD2			DATA								UNIT	C	LF	

3. The net weight (+15.0624 HK tael) shows as below, after stable: (tare or pre-tare mode)

S	T	,	N	T	,	+	1	5	.	0	6	.	2	4	h	k	g	0D	0A
HEAD1			HEAD2			DATA								UNIT	C	LF			

4. The net weight (+1.245 viss) shows as below, after stable: (tare or pre-tare mode)

S	T	,	T	R	,	+			1	.	2	4	5	v	i	s	s	0D	0A
HEAD1			HEAD2			DATA								UNIT	C	LF			

Press  key to transmit (simple mode)   

S/N WT/UNIT (kg / lb)

0001 1.0000

→ Press  or  key

0002 1.0000

→ Press  or  key

0003 1.0000

→ Press  or  key

0004 1.0000

→ Press  or  key

0005 1.0000

→ Press  or  key

0005 5.0000

→ Press  twice to print TOTAL

Press  key to transmit (complete mode)   

TICKET NO.0001
G 1.000kg
T 0.000kg
N 1.000kg
(3 blank lines)

→ Press  or  key

TICKET NO.0002
G 1.000kg
T 0.000kg
N 1.000kg
(3 blank lines)

→ Press  or  key

TICKET NO.0003
G 1.000kg
T 0.000kg
N 1.000kg
(3 blank lines)

→ Press  or  key





TOTAL NUMBER
OF TICKETS 0003
TOTAL
NET 3.000kg
(3 blank lines)



→ Press  twice to print TOTAL

 G = GROSS T = TARE PT = PRE-TARE N = NET

Stable Transmission (totalizing mode)

S/N WT/UNIT (kg / lb)



0001	1.0000		The scale is stable
0002	1.0000		The scale is stable
0003	1.0000		The scale is stable
0004	1.0000		The scale is stable
0005	1.0000		The scale is stable

0005	5.0000		Press  twice to print TOTAL

RS232 and Mini Printer output format in HOLD MODE

Please set  in .

1. If there is only RS232, press  key to print out the HOLD value on display in HOLD MODE.
2. Mini printer data transmission format in HOLD condition

When  is set as  or  (English or Iranian font),

The format for 1.000kg is as follows:

			1	.	0	0	0	k	g	0D	0A
--	--	--	---	---	---	---	---	---	---	----	----

Remarks

1. Printer fonts differ from different countries.
2. RS232 is always in English font (ASCII)



Continuous Transmission (specific form) (Brazil customer)

The print form is as below:

If display shows 70.15kg, the RS-232 export is 51.07000

If display shows -70.15kg, the RS-232 export is 51.0700-

If display shows OL, then it print nothing.



or



key Transmission (specific form)

F	R	"	W	T	3	N	"	<LF>												
?	<LF>																			
G	G	,	G	G	G	<LF>														
T	T	,	T	T	T	<LF>														
PT	PT	,	PT	PT	PT	<LF>														
N	N	,	N	N	N	<LF>														
pcs	pcs	pcs	pcs	pcs	pcs	<LF>														
n	n	n	n	n	n	t	t	t	t	t	t	pcs	pcs	pcs	pcs	pcs	pcs	<LF>		
p	1	,	1	<LF>																

For example:

PT 0.3KG

T 0.7KG

G 1.2KG

N 0.2KG

PCS 20

Then the printing form is:

FR"WT3N "

?

1,200

0,700

0,300

0,200

20

000020001000000020

P1,1

Use + key to clear the format.

Then, form clearing the printing:

F	R	"	5				"	<LF>												
?	<LF>																			
TN	TN	TN	TN	TN	TN	<LF>														
TW	TW	TW	TW	TW	TW	<LF>														
TA	TA	TA	TA	TA	TA	<LF>														
tn	tn	tn	tn	tn	tn	<LF>														
tn	tn	tn	tn	tn	tn	tw	tw	tw	tw	tw	tw	tw	tw	tw	tw	tw	tw	tw	tw	<LF>
p	1	,	1	<LF>																

FR"520T "

?

1

0,200

20

000001000200000020

P1,1



Self-test Function of Printer (option)

Hold  key and switch on the printer, it will automatically print self-test data.

```

-----
VERSION : 10004010      ↗ Program version
DATE : 2000/01/04      ↗ Printer date
TIME : 20 : 06 : 50    ↗ Printer time
MODE : TAIWAN          ↗ Printer language
MEMORY TEST OK        ↗ Printer status

```

The test of Printer

1. Press and hold  key to enter into.

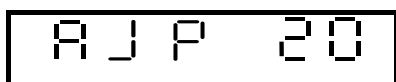

Default : 20

2. Press  or  key to adjust the number.

3. Press  key to print.

4. Input the proper value to adjust the word space. An example is shown below.

```

-----
VERSION: 1000 4010
DATE : 20 08 / 0 5 / 28
TIME : 09 : 5 9 : 03
MODE : IRAN
MEMORY TEST OK
:
: 0000 0000 0000 0000
:

```

**word space too high
please adjust it to a lower value**

```

-----
VERSION: 10004010
DATE : 2008 / 05 / 28
TIME : 09 : 59 : 18
MODE : IRAN
MEMORY TEST OK
-----
00000000000000000000

```

good word space

```

-----
VERSION: 10001010
DATE: 2008 / 05 / 28
TIME: 09 : 59 : 33
MODE: IRAN
MEMORY TEST OK
-----
00000000000000000000

```

**word space too low
please adjust it to a higher value**

5. Press  key to restart the printer.

3-3 F 6 ⇒ Exit Setting Mode

Press  or  key to select F6 function ⇒ the display shows F 6

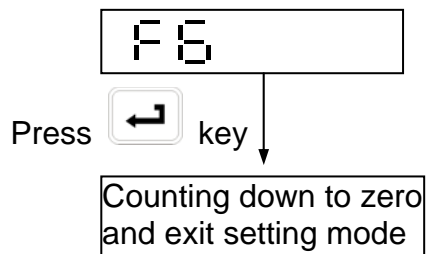

3-4 F 7 ⇒ Internal Value Display Mode

Press  or  key to select F7 function ⇒ the display shows F 7

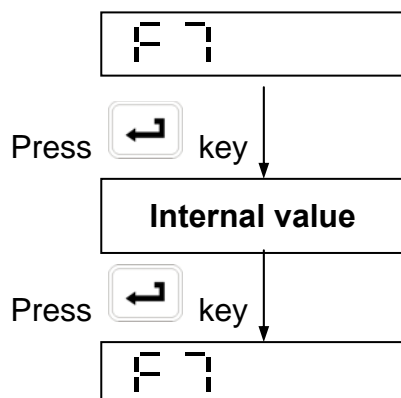



3-5 F10 ⇒ G value Calibration

Press key or key to select F10 function. ⇒ The display shows F10.

You can input at most 9 sets of G value's data. The historic data can be found out and not to be revised.

F 10

- 06 -

After about 1 second

9.79555

Press key ↓ ↑ Press key
The screen displays revised times at present and then displays local G value after about 1 second.

- 05 -

After about 1 second

9.79885

Press key ↓ ↑ Press key
The screen displays last revised times and then displays local G value after about 1 second.

- 04 -

After about 1 second

9.79000

Press key ↓ ↑ Press key
The screen displays the first two revised times and then displays local G value after about 1 second.

- 01 -

After about 1 second

9.789 14

Press key ↓ ↑ Press key
"01" ⇒ Fix to save ADJ condition, input local G value in F9.

- 00 -

After about 1 second

9.79423

Press key to enter into G value revised mode
"00" ⇒ Fix to save G value in manufacture site.

9.79423

Input local G value

9.789 14



Press and key to input the number. Press key to Shift the flashing digit one space to right.

Press key to save the data and then complete the revise.



F 10

3-6 F I I ⇒ ID Code Setting

(Use must be in coordination with F 5 r n P 1 , 2 , 8)

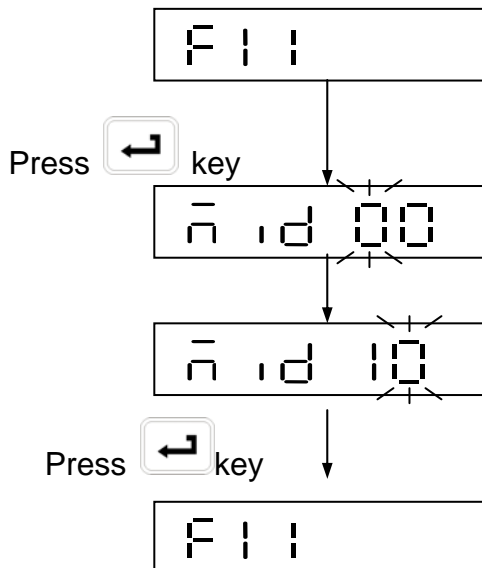
Press  key or  key to select F11 function ⇒ the display shows F I I



Machine ID code setting:
 Press  and  to set 01 ~ 99
 Default setting: 00
 (1) "00": RS-232 does not transmit Machine ID
 (2) "01~99": RS-232 transmits Machine ID

RS232 DATA FORMAT

Stable transmission (r n P 1), Continuous transmission (r n P 2),

Press  key to transmit (r n P 8)

1. e.g. Machine ID code is 10.

The gross weight (+0.876 kg) shows as below, after stable: (no tare or under pre-tare mode)

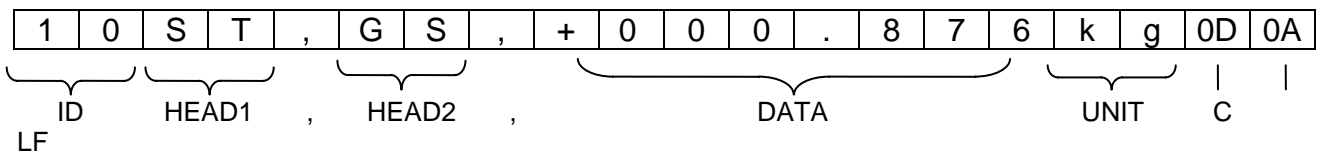

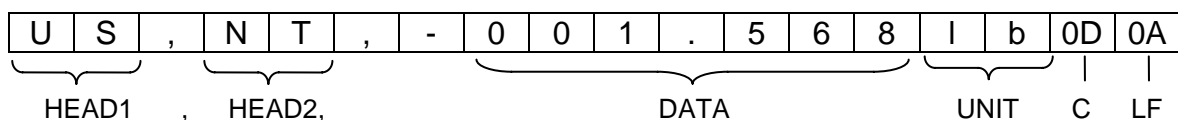

2. e.g. Machine ID code is 00. (Not using Machine ID function.)

The net weight (-1.568 lb) shows as below without weight stability: (under tare or pre-tare mode)



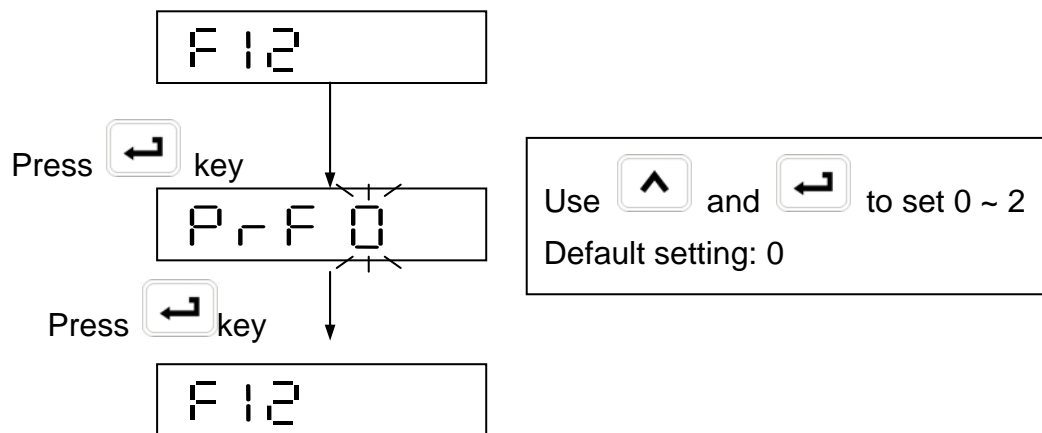

3-7 F12 ⇒ Print Key (⊙) Function Setting

Press  key or  key to select F12 function ⇒ the display shows F 12



P r F 0 ⇒ Press  key to print current weight if weight variation is within $\pm 1d$ ~ $\pm 10d$, or to print accumulated weight if weight variation is over $\pm 10d$. (d=division)

P r F 1 ⇒ Press  key to print the current weight at once. (no totalization)

P r F 2 ⇒ Press  key to print the current weight if it is within the lower and upper limits. (no totalization)

3-8 F 14 ⇒ Printing orders when F 5 is set as r n P 6 or r n P 7

No.0	No print.
No.1	TICKET NO.
No.2	G
No.3	T
No.4	PT
No.5	N
No.6	P/N
No.7	S/N
No.8	DATE (mini_printer is required)
No.9	TIME (mini_printer is required)







F 14 contains a 9-digit code

Example:

If F 14 is set as 8900000000

① The format of r n P 6 is as following

DATE: 2011/04/11
 TIME: 11:28:21
 S/N WT/UNIT (kg / lb)

0001	1.0000	⇒ Press  key or Press  key
0002	1.0000	⇒ Press  key or Press  key
0003	1.0000	⇒ Press  key or Press  key
0004	1.0000	⇒ Press  key or Press  key
0005	1.0000	⇒ Press  key or Press  key

0005	5.0000	⇒ Press  key twice to print the total

② The format of r n P 7 is as following

DATE: 2011/04/11
 TIME: 11:29:20

⇒ Press  key or Press  key



If F14 is set as 896 123 450

1 The format of [F14] [F15] [F16] [F17] is as following

DATE: 2011/04/11
 TIME: 11:29:20
 P/N 012345678910
 TICKET NO. 0001
 G 75.01kg
 T 0.00kg
 PT 0.00kg
 N 75.01kg
 S/N WT/UNIT (kg / lb)

0001	1.0000	→ Press		key or Press		key
0002	1.0000	→ Press		key or Press		key
0003	1.0000	→ Press		key or Press		key
0004	1.0000	→ Press		key or Press		key
0005	1.0000	→ Press		key or Press		key

0005	5.0000	→ Press		key twice to print the total.
------	--------	---------	--	-------------------------------

2 The format of [F14] [F15] [F16] [F17] is as following

DATE: 2011/04/11
 TIME: 11:29:20
 TICKET NO. 0001
 G 75.01kg
 T 0.00kg
 PT 0.00kg
 N 75.01kg

→ Press or key

DATE: 2011/04/11
 TIME: 11:29:20
 TOTAL NUMBER
 OF TICKETS 0001
 TOTAL
 NET 0.499kg

→ Press or key twice to print the total



PN (Part No.)

SN (Serial No.)

Setup method:

In weighing mode, hold  key for 2 seconds to setup.

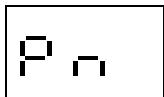

1 second ⇒

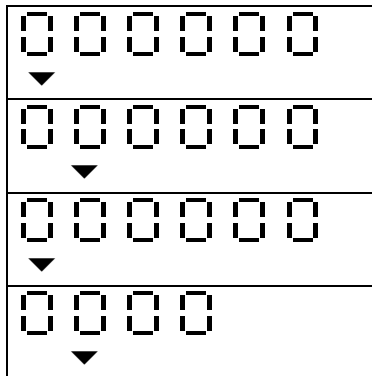





Use ,  key to enter 12-digit Part number

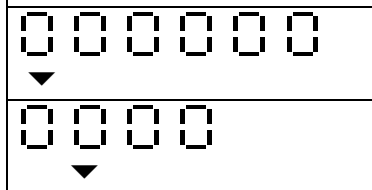

1 second ⇒



Use ,  key to enter 10-digit Serial number

-  After power-off, S/N will reset as 1.
-  P/N will be saved in memory, available during next power-on.



Appendix 1 Optional Function Description

RS-232 output description

1. Please refer to F5 function settings for transmission mode, baud rate setting and data format.

2. RS232(DB25PIN) Pin Description

- J1, J3 SHORT; J2, J4 OPEN (default setting)

Pin 2 ⇒ TXD

Pin 3 ⇒ RXD

Pin 5 ⇒ GND

Other pins are disabled.

- J2, J4 SHORT; J1, J3 OPEN

Pin 2 ⇒ RXD

Pin 3 ⇒ TXD

Pin 5 ⇒ GND

Other pins are disabled.



Appendix 2 Load Cell Pin Description (Input signal)

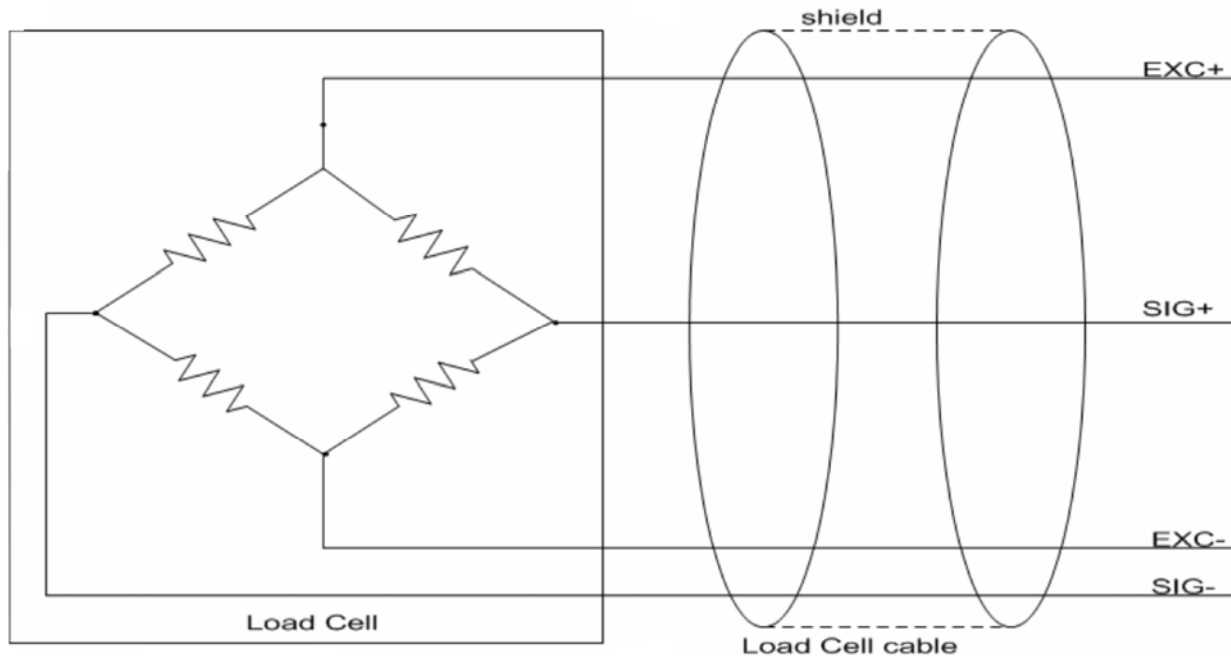

- Pin1 ⇒ E + (EXCITAION +)
- Pin2 ⇒ E - (EXCITAION -)
- Pin3 ⇒ S + (SIGNAL +)
- Pin4 ⇒ S - (SIGNAL -)
- Pin5 ⇒ Shield

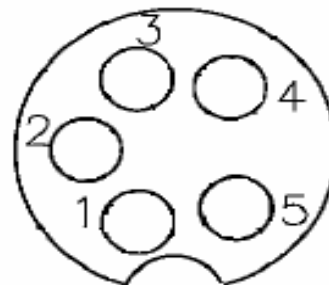

4 line(5 line)Load Call

FB model

JP21,JP22 short circuit (short)

PCB	⇒	L/C
(E+)	⇒	EXC+
(E -)	⇒	EXC -
(S+)	⇒	SIG+
(S -)	⇒	SIG -
(FG)	⇒	shield

Note: JP21 and JP22 are on the PCB board of FB model.

Appendix 3 Printer Installation

A. Roll paper installation and problems solution

1. Installation roll paper:

- Use designated roll paper with a width 44.5 ± 0.5 mm and internal diameter 50 mm.
- Fix the roll paper into the paper entrance of the Printer.
- Cut the edge of the paper leveling and then install the paper (refer to **V** of picture A). And then use **Feed** key to complete installation (make sure the paper is parallel with the printing location. Avoid operating as **X** of picture A)
- The paper should not be folded or broken.

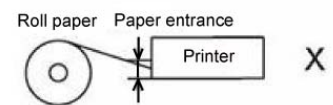
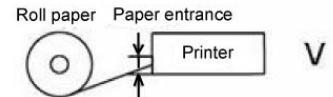

Picture A

2. Uninstall roll paper:

- Cut up the paper at the entrance of Printer, and then pull out the paper from the exit of Printer.

3. Paper jam solutions procedures:

- Uninstall the paper first.
- Use a nipper or others to clear remain wastepaper.

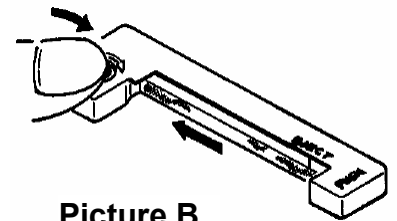

Picture B

B. Ribbon installation

- Use designated ribbon. (ERC-05)
- Uninstall the roll paper before install the ribbon. (Picture B)
- Turn and tighten the ribbon before installation.
- Sway the ribbon to proper location according to Picture C. If the ribbon loosens during installation, retighten it according to Picture D.
- To uninstall the ribbon, press gently the location in Picture E, and then take it out with proper adjustment.
- The ribbon of the model received may deviate its location during its transportation, and this may lead to the breakdown of the Printer. To solve this problem, reinstall the ribbon according to the above procedures.

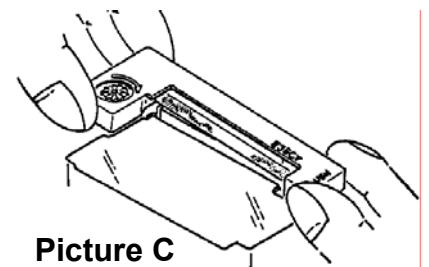

Picture C

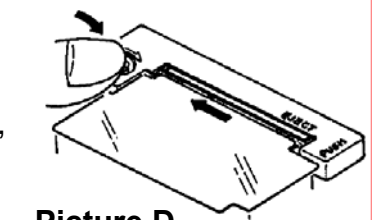

Picture D

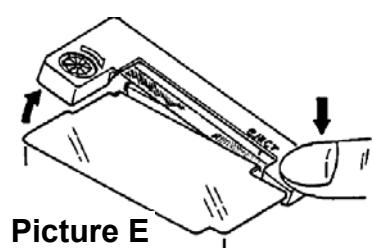

Picture E



Appendix 4 Load Hook Installation

Please install the load hook (only for FB-630) according to correct order as follows.

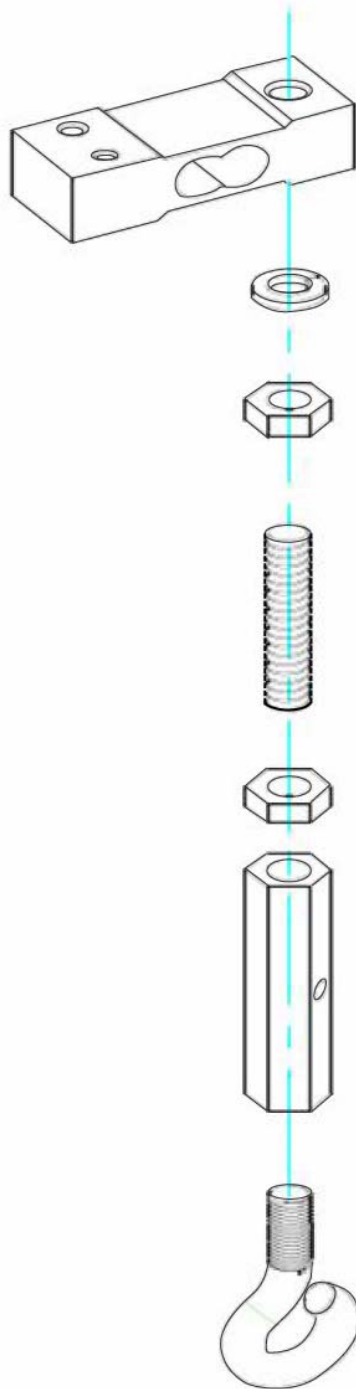



Appendix 5 7-Segment Display Characters

Number	Display	Letter	Display	Letter	Display
0		A		N	
1		B		O	
2		C		P	
3		D		Q	
4		E		R	
5		F		S	
6		G		T	
7		H		U	
8		I		V	
9		J		W	
		K		X	
		L		Y	
°C		M		Z	