

JET *motion*

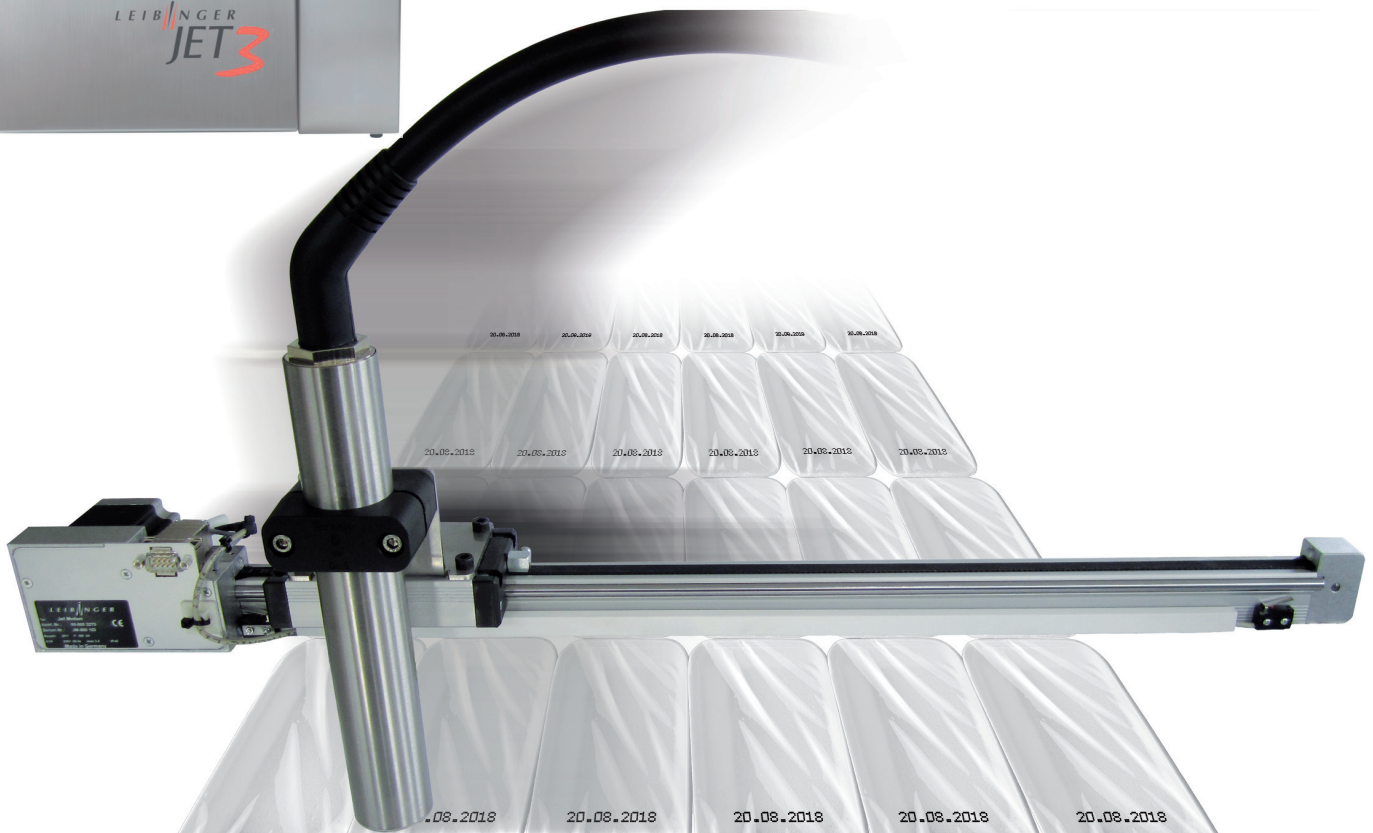

The traverse system from Leibinger

Printer and crossbar from one source – the perfect system solution

LEIBINGER



JETmotion

JETmotion – the automated traverse system for the printer series JET2SE and JET3. For all applications where the printhead should be moved over the product.

On the automated traverse, a printhead will be installed and moved vertically. Single or multiple products can thus easily be imprinted in a row. This system qualifies for different printing demands such as tubes, PCB, electro- and electronic components, steel- or plastic products of all sorts. In combination with a Leibinger JET2SE or JET3 printer, JETmotion guarantees an optimal printing solution.

- Safe and very fast movement of the printhead for marking of all sorts of products
- Multitrack imprint of moving parts, e.g. for extrusion of plastic profiles
- Product marking in forward or backward motion with automated switching of the printing direction
- Integrated synchronisation of the movement speed with the printout

JETmotion also qualifies in intermittent motion machines, such as thermoformed packaging machines: The idle period is used for imprinting the products. After every step of the packaging machine the JETmotion axis moves the printhead across the filled and sealed trays and imprints every single tray of the entire row with the desired information.

After the next machine step the process repeats itself in reverse sequence and the next row of trays is imprinted by the inkjet printer on its way back.

Plug and Play:

- Quick and flexible mounting by movable attachment rail with threaded drillings at the traverse bottom side
- Software can quickly and easily be adjusted to the specific application. Parameters such as speed and distance can individually be adjusted
- Simple installation via plug-and-play: Plug in, switch on, done!

Scope of delivery:

- Standard axis with engine and sliding carriage, length of axis: 600 millimeters (=23.62 inches) (marking length: 443 millimeters (=17.44 inches))
- Standard printhead bracket
- JETmotion controller for axis control (4 inputs, 4 outputs, emergency stop)
- Software for parametrization of JETmotion
- Complete wire harness (connection between inkjet printer and JETmotion)

JETmotion is available in the versions JETmotion3 for JET3 printers and JETmotion2 for JET2SE printers. Each version can be delivered in 230 or 120 voltage.

On request there is a stainless steel version of the traverse available as well as different lengths of traverses up to 6000 millimeters (=236.22 inches) (max. marking length: 5840 millimeters (=229.92 inches)). It is even possible to upgrade JETmotion to a multiple axis system (xy).

Accessories:

- "Two-handed operation" key button for work stations with manual start
- Pedal switch

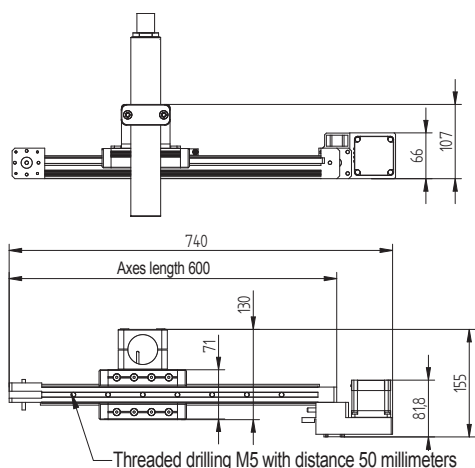

Technical Specifications

Effective movement length of the axis at 600 millimeters (=23.62 inches) standard length = 443 millimeters (=17.44 inches) marking length.

Speed max	0,8 m (31.5 inches)/sec
Weight in movement	2,5 kg (5.5 pounds)
Drive	2 stage step motor
I/O – Inputs	4
I/O – Outputs	4
Encoder	RS422
Cable connection set for JET2 / JET3	



Paul Leibinger GmbH & Co. KG
 Daimlerstr. 14
 D-78532 Tuttlingen
 Phone +49 (0) 74 61 / 92 86 - 0
 Fax +49 (0) 74 61 / 92 86 - 199

www.leibinger-group.com
 info@leibinger-group.com



Local distributor contact: