

# WKE Series

## Explosion-proof Rechargeable LED Hand Lamp



### Product Overview

The Explosion-proof Rechargeable LED Hand Lamp, representing advanced engineering technology, features superior performance, durability, and versatility in harsh environments. It is UL, ATEX, and IECEx certified, for safe use in explosive gas atmospheres (zone 0, 1, and 2) and dust atmospheres (zones 21, and 22).

The WKE series include a range of models, catering to various applications. Each model has two modes: spotlight and floodlight; both of the two modes can be switched to strong light state or work light state. Dual-color signal light function is available by pressing the switch in the instructed way. See our instruction manual for more detail.

Compact and lightweight, the high-strength housing is proven to resist shock; the rubber-reinforced lens ring and handle provide better grip and shock protection. The lens is resistant to wear and corrosion; the housing is electrostatic safe and IP67 certified. The hand light can be easily switched with one hand, even when wearing gloves, for easy function selection.

### Certifications:

- ◆ Marking ATEX & IECEx
  - ◆ Industrial: II 1G Ex ia IIC T4 Ga IP67
  - ◆ Industrial: II 2D Ex ib IIIC T135°C Db
  - ◆ Mining: I M1 Ex ia I Ma IP67
- ◆ Area of Classification (Gas):
  - ◆ Zones 0,1 and 2 Gas Groups IIA, IIB, IIC
- ◆ Area of Classification (Dust):
  - ◆ Zones 21 and 22
- ◆ Type of Protection: "ia" intrinsic safety
- ◆ IP67
- ◆ Marking UL844 (North American)
  - ◆ Class I, Division 1, Groups A, B, C, D
  - ◆ Class I, Division 2, Groups A, B, C, D
  - ◆ Class II, Division 1, Groups E, F, G
  - ◆ Class II, Division 2, Groups F, G
  - ◆ Class III
- ◆ Working Temperature: -22°F to 104°F (-30°C to 40°C)
- ◆ Temperature Classification (Gas): T4
- ◆ Max. Surface Temperature (Dust): (135°C)275°F

### Technical Information:

- ① Bright high power LED light source with 350 lumens measured.
- ② Lifespan of light source is more than 25,000 hours.
- ③ Input Voltage: 7.4V.
- ④ Lithium-Ion battery is rechargeable. Battery life is up to 500 recharge cycles.
- ⑤ Light duration up to 7 hours (working light) or 3 hours (strong light) from a single charge.
- ⑥ Compatible charger: AC90V-264V.
- ⑦ Charger input voltage: DC12V, 1500mA max.
- ⑧ Power source capacity: 6400mAh, 7.4V, 47.36Wh.
- ⑨ Recharge time: 2 hours (quick charge); 24 hours (fully charged).
- ⑩ Suitable for cyclic and short and long term standby applications.

### Key Features:

- ◆ Emergency illumination mode will be activated if power to the charger fails.
- ◆ Three beam options switchable: spotlight, floodlight and signal light.
- ◆ Impact-resistant thermoplastic enclosure and anti-static / toughened glass.
- ◆ Deep discharge protection protects the battery from permanent damage.

### Standard Materials:

- ◆ Lens: Toughened glass
- ◆ Battery: Lithium-Ion

### Catalog Number Logic:

**EX - 002W - WKE - RY/RG/YG**

①

②

③

④

- |   |   |                       |  |
|---|---|-----------------------|--|
| <p>① PRODUCT CATEGORY</p> <ul style="list-style-type: none"> <li>◆ Explosion-proof light</li> </ul> | <p>② WATTAGE</p> <ul style="list-style-type: none"> <li>◆ 2W</li> </ul> | <p>③ PRODUCT CODE</p> | <p>④ COLOR OF SIGNAL LIGHT</p> <ul style="list-style-type: none"> <li>◆ RY: Red and Yellow</li> <li>◆ RG: Red and Green</li> <li>◆ YG: Yellow and Green</li> </ul> |
|---|---|-----------------------|--|

## Packing Information:

Model	Quantity/Carton	Packing Size	Net Weight	Gross Weight
EX-002W-WKE-RY/RG/YG	1 Pc	11.81x7.48x5.12inch/ 300x190x130mm	1.33 kg/ 2.93 lbs	1.62 kg/ 3.57 lbs

## Dimension:

Unit: inch/mm

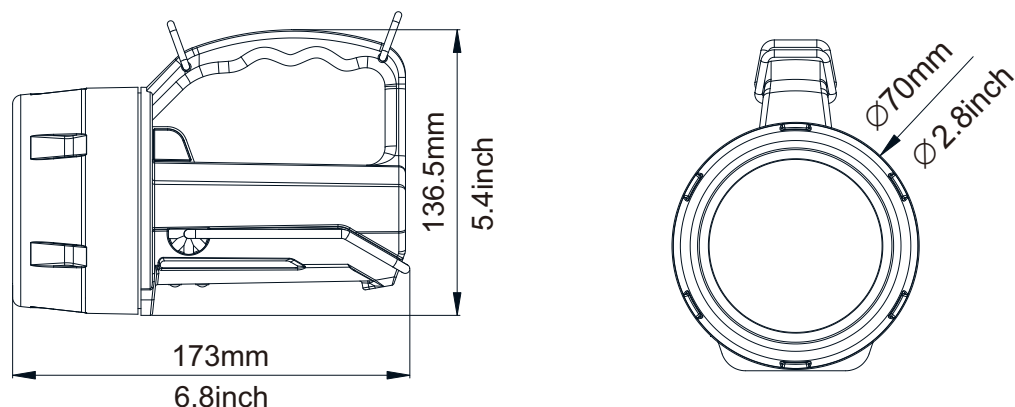

## Charging Instructions:

- ◆ Connect the charging cable to the charger and power socket, the red indicator of the charger is on.
- ◆ Connect the lamp to the charger, and the lamp's power indicator light is flashing -- Charging.
- ◆ Three power indicator lights are on -- Ready.
- ◆ Safety Tips:
  - Do not charge in a hazardous area.
  - Do not operate the product with the charger connected.
  - Do not use the product if its front cover, glass or housing is cracked.
  - Use approved battery pack only.
  - Use approved charger only: ex-002w-wke-charger.
  - Charger input voltage: 12~24V.
  - Charge temperature: -4°F to 104°F(-20°C ~40°C).