

NXY 2 axes

● Arm type ● Cable carrier



Ordering method

NXY - C [] [] [] [] **RCX222** [] **R** [] []

Model	Cable	Combination	X-axis stroke	Y-axis stroke	Cable length	Controller	Usable for CE	Regenerative unit	Input/Output selection 1	Input/Output selection 2
	A1 A3		50 to 200cm	15 to 65cm	3L: 3.5m (Standard) 5L: 5m 10L: 10m	RCX222	No entry: Standard E: CE marking	R: RG2	N: NPN P: PNP CC: CC-Link DN: DeviceNet PB: Profibus EN: Ethernet YC: YC-Link	No entry: None N1: OP.DIO24/16 (NPN) P1: OP.DIO24/17 (PNP) EN: Ethernet

Note 1. NPN and Ethernet cannot be selected if using CE marking.
Note 2. Available only for the master.
Note 3. Only when CC or DN or PB was selected for I/O select 1 above. EN can be selected in I/O select 2.

Specification

	X-axis	Y-axis
Axis construction	N15	F14
AC servo motor output (W)	400	100
Repeatability (mm)	+/-0.01	+/-0.01
Drive system	Ball screw (Class C7) φ15	Ball screw (Class C7) φ15
Ball screw lead (Deceleration ratio) (mm)	20	20
Maximum speed (mm/sec)	1200	1200
Moving range (mm)	500 to 2000	150 to 650
Robot cable length (m)	Standard: 3.5 Option: 5,10	

Note 1. Use caution that the flame machining (installation holes, tap holes) differs from single-axis robots.
Note 2. Positioning repeatability in one direction.

Maximum payload (kg)

Y stroke (mm)	XY 2 axes
150	25
250	21
350	18
450	16
550	13
650	11

Controller

Controller	Operation method
RCX222-R	Programming / I/O point trace / Remote command / Operation using RS-232C communication

NXY 2 axes A1

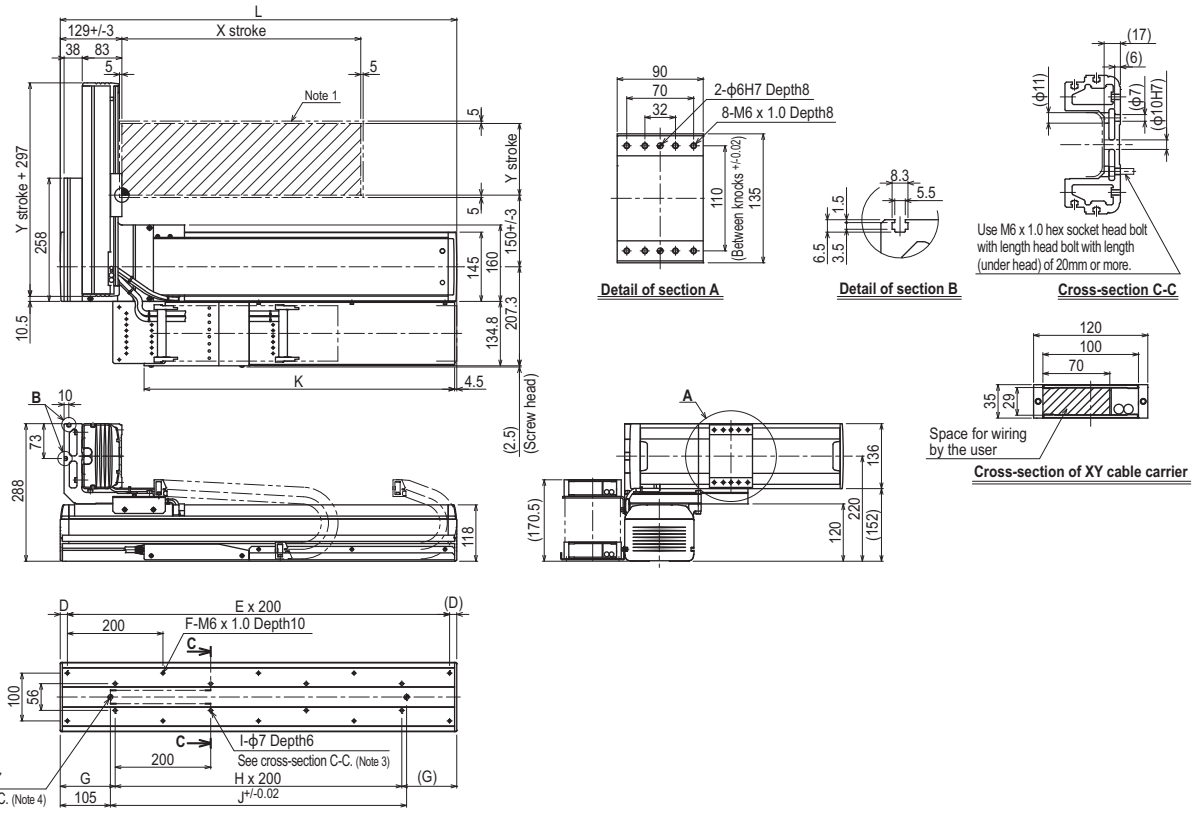

X stroke	500	600	700	800	900	1000	1100	1200	1300	1400	1500	1600	1700	1800	1900	2000
L	830	930	1030	1130	1230	1330	1430	1530	1630	1730	1830	1930	2030	2130	2230	2330
D	15	65	15	65	15	65	15	65	15	65	15	65	15	65	15	65
E	4	4	5	5	6	6	7	7	8	8	9	9	10	10	11	11
F	10	10	12	12	14	14	16	16	18	18	20	20	22	22	24	24
G	115	165	115	165	115	165	115	165	115	165	115	165	115	165	115	165
H	3	3	4	4	5	5	6	6	7	7	8	8	9	9	10	10
I	8	8	10	10	12	12	14	14	16	16	18	18	20	20	22	22
J	620	720	820	920	1020	1120	1220	1320	1420	1520	1620	1720	1820	1920	2020	2120
K	650	700	750	800	850	900	950	1000	1050	1100	1150	1200	1250	1300	1350	1400
Y stroke	150	250	350	450	550	650										

Note 1. The moving range when returning to origin and the stop position when stopping by the mechanical stopper.
Note 2. The origin of the X axis is set originally as the drawing and it is possible to change it to the R side origin by changing parameters.
Note 3. When using φ7 holes for installation, you must not use a washer, spring washer, etc. in the main unit.
Note 4. When using a φ10H7 hole, make sure that the pin does not go into deeper than as shown in the drawing.
Note 5. Use M4 tap of the box next to X axis for the user grounding terminal.
Note 6. The M4 taps at both ends of the cable carriage can be used for fixing cables.

NXY 2 axes **A3**

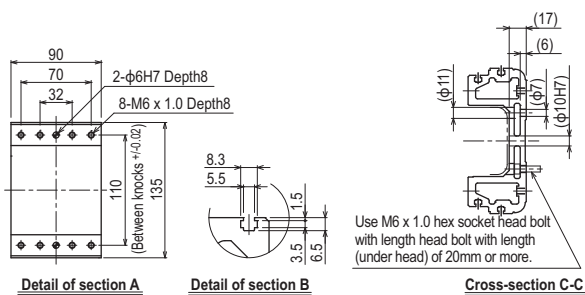

Detail of section A

Detail of section B

Cross-section C-C

Use M6 x 1.0 hex socket head bolt with length head bolt with length (under head) of 20mm or more.

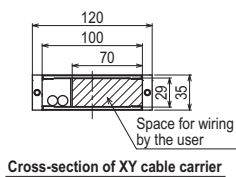

Cross-section of XY cable carrier

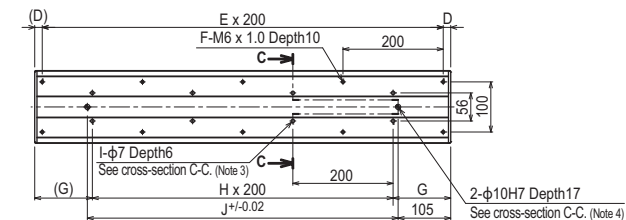
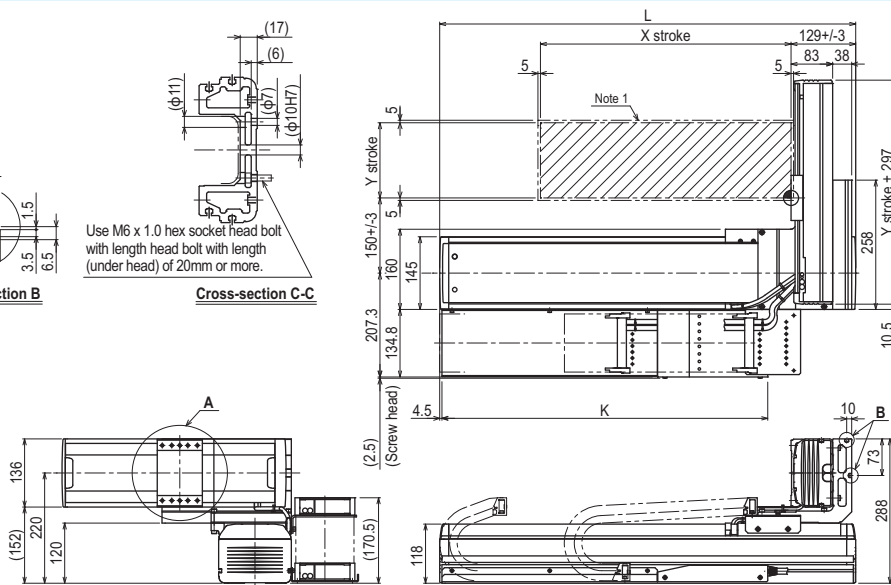

X stroke	500	600	700	800	900	1000	1100	1200	1300	1400	1500	1600	1700	1800	1900	2000
L	830	930	1030	1130	1230	1330	1430	1530	1630	1730	1830	1930	2030	2130	2230	2330
D	15	65	15	65	15	65	15	65	15	65	15	65	15	65	15	65
E	4	4	5	5	6	6	7	7	8	8	9	9	10	10	11	11
F	10	10	12	12	14	14	16	16	18	18	20	20	22	22	24	24
G	115	165	115	165	115	165	115	165	115	165	115	165	115	165	115	165
H	3	3	4	4	5	5	6	6	7	7	8	8	9	9	10	10
I	8	8	10	10	12	12	14	14	16	16	18	18	20	20	22	22
J	620	720	820	920	1020	1120	1220	1320	1420	1520	1620	1720	1820	1920	2020	2120
K	650	700	750	800	850	900	950	1000	1050	1100	1150	1200	1250	1300	1350	1400
Y stroke	150	250	350	450	550	650										

- Note 1. The moving range when returning to origin and the stop position when stopping by the mechanical stopper.
- Note 2. The origin of the X axis is set originally as the drawing and it is possible to change it to the R side origin by changing parameters.
- Note 3. When using φ7 holes for installation, you must not use a washer, spring washer, etc. in the main unit.
- Note 4. When using a φ10H7 hole, make sure that the pin does not go into deeper than as shown in the drawing.
- Note 5. Use M4 tap of the box next to X axis for the user grounding terminal.
- Note 6. The M4 taps at both ends of the cable carriage can be used for fixing cables.