

HDPE DOUBLE WALL CORRUGATED SEWER AND DRAINAGE PIPE



B BINA PLASTIC
INDUSTRIES SDN BHD
(Co.No. 54840-T)

© TECHNICAL DATA

Product Standard : DIN 16961					
Nominal diameter, DN	(mm)	100	150	225	300
	(inch)	4	6	9	12
Outside diameter, OD	(mm)	118	173	262	346
Inside diameter, ID	(mm)	100	150	225	300

Standard Length : 6 meters

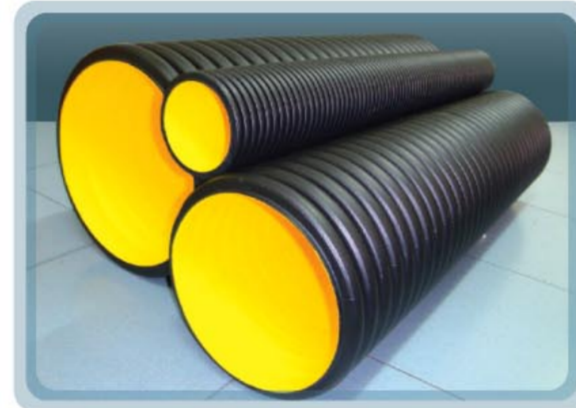
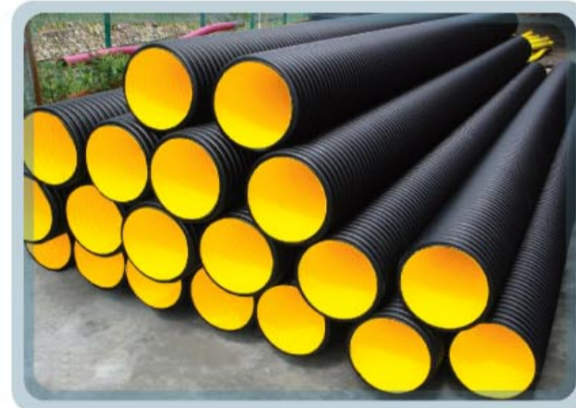
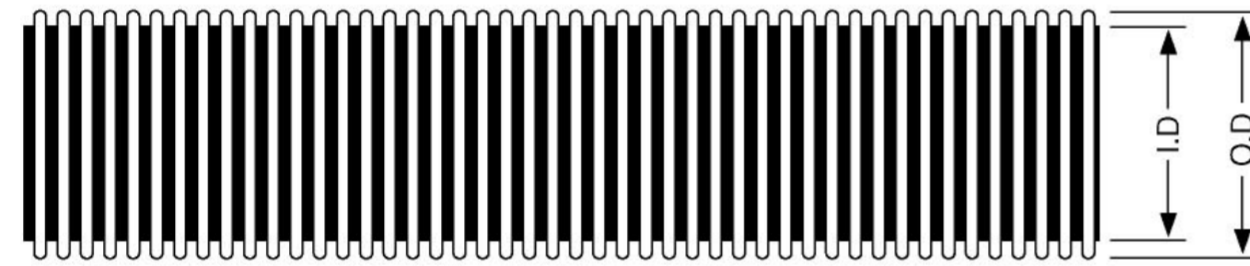

BBB™
HDPE DOUBLE WALL CORRUGATED
SEWER AND DRAINAGE PIPE

INTRODUCTION

BBB™ High Density Polyethylene (HDPE) Double Wall Corrugated Sewer and Drainage Pipes are for gravity and low pressure sewerage and drainage such as waste water, sanitary sewer and storm sewerage for municipal or industrial use. The pipes provide important benefits and distinct advantages for sewer and drainage applications.

ADVANTAGES

⊙ Lightweight

HDPE corrugated pipes are lighter than other traditional pipes. Result in quick and reliable installation. The pipe can be transported easily to job site, even in poor ground conditions.

⊙ Flexible

HDPE corrugated pipes are flexible, allowing them to adjust to different loading conditions, stresses, vibrations and soil movements without causing damage to the pipes. Situation is opposite for rigid pipes, which break when their crush strength is exceeded.

⊙ Easy Installation

Installing the pipes is simple and easy. Important factors are lightweight of the pipe, ease of handling, transporting to job site and method of installation (rubber ring joint). Longer pipe lengths speed up installation time, reduce number of joints, hence reducing the number of potential leaks and help reduce the installation costs.

⊙ Chemical and Abrasion Resistant

HDPE have excellent chemical resistance and are unaffected by soils and sewerage effluents with wide range of PH. It is highly resistant to the wet, hydrogen sulfide gas and the low concentration acid found in sanitary sewer. HDPE corrugated pipes have superior abrasion resistant qualities. Installed correctly, HDPE corrugated sewer and drainage pipe systems can provide long service life.

⊙ Hydraulic Efficiency

The smooth interior of HDPE corrugated pipe provides the superior flow characteristics that are essential for conveying and discharging fluids. HDPE corrugated pipe does not corrode or tuberculate and maintain its flow capability over time.

⊙ Structural Performance

HDPE is an extremely tough material that can easily withstand normal impacts involved in transportation and installation. The strength of HDPE corrugated pipe is derived from its corrugated profile, allow it to support compressive loading from covering layers and traffic.

INJECTION MOULDING FITTING

Ribs design increases fitting ring stiffness to withstand compressive loading

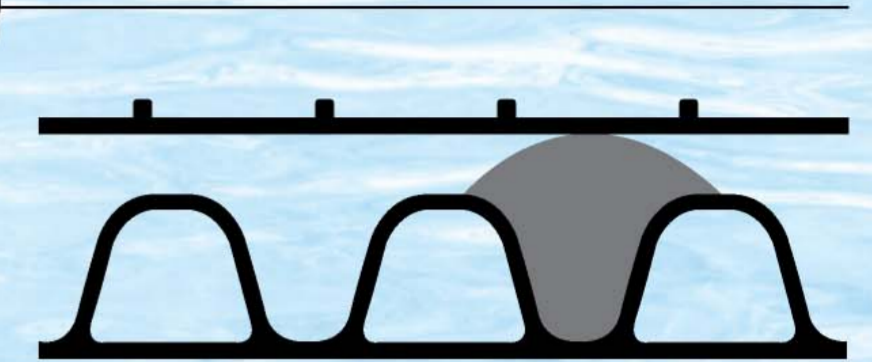

PUSH-FIT SOCKET

EPDM rubber ring placed in second groove from pipe end provides watertight joint

⊙ Fittings

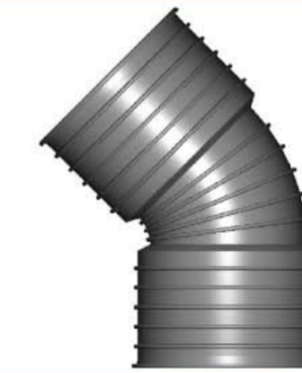

45° Bend

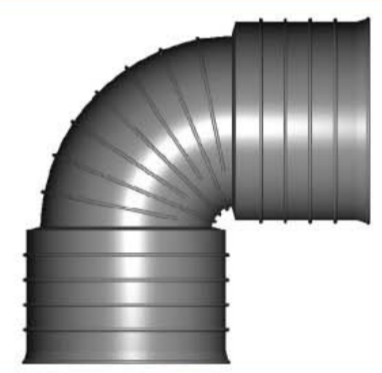

90° Bend

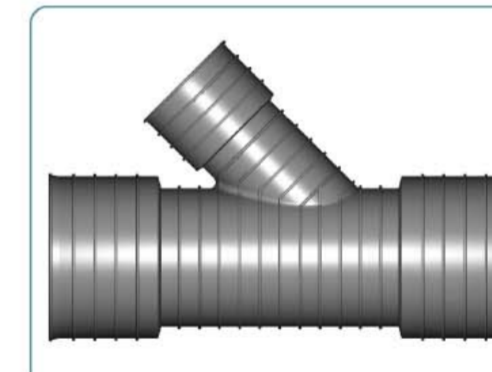

Reducing 45° Branch

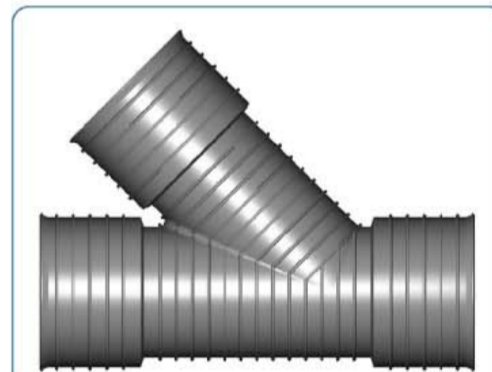

45° Branch

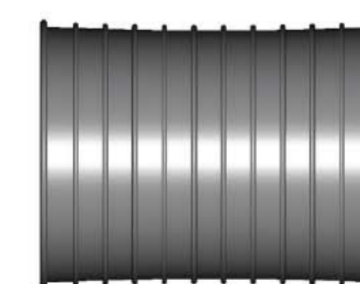

Coupler



End Cap

