



LYE

CHECK VALVES

DOUBLE DOOR WAFER TYPE CHECK VALVE FOR WATER PUMPING SYSTEMS

ICAL MONITORING

In Brief

- ▶ Most Compact & Common Category of Check Valve Used in Water Pumping Systems
- ▶ Good Non-Slam Operation with Short Linear Disc Stroke Closing by Torsion Spring
- ▶ Working Pressure : 10/16 bar
- ▶ Shell Test Pressure : 15/24 bar
- ▶ Seat Test Pressure : 11/17.6 bar
- ▶ Temperature Range : 0°C - 80°C
- ▶ Coating : Fusion Bonded Epoxy
- ▶ Sealing : EPDM



Standards

- ▶ Test : BS EN 12266-1
- ▶ For Connecting End : BS EN 1092-2
PN10/PN16,
JIS B2212 10K, BS
Table D/E, AS 2129
Table E, ASME B16.5
CL150

Features

- ▶ Range of Valve Sizes : DN50 to DN600
- ▶ Great Installation Advantages with Small Occupancy of Space for Easy Disassembly & Maintenance
- ▶ Universal Flange Connection for Vertical & Horizontal Installation
- ▶ Ideal for Vertical Pipeline Installation in Delivering Upwards Flow

DOUBLE DOOR WAFER TYPE CHECK VALVE FOR WATER PUMPING SYSTEMS

Technical Table

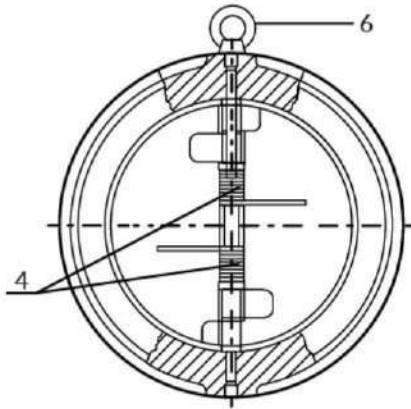
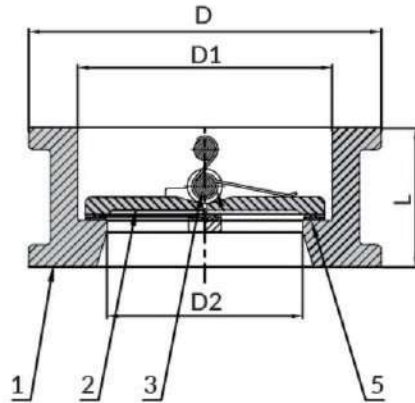

Parts List & Materials

No.	Component	Material	Standard Ref.
1	Body	Ductile Iron	BS EN 1563
2	Disc	Ductile Iron	BS EN 1563
3	Stem	Stainless Steel	BS EN 10088-3
4	Spring	Stainless Steel	BS EN 10088-3
5	Seat	EPDM	BS EN 681
6	*Lifting Bolt	Ductile Iron	BS EN 1563

*For Valve Sizes \geq DN400

Specifications & Parameters Chart

DN (mm)	L (mm)	D (mm)	D1 (mm)	D2 (mm)
50	54	107	64	46
65	54	127	79	60
80	57	142	94	70
100	64	162	117	84
125	70	192	145	115
150	76	218	170	134
200	95	273	224	184
250	108	328	265	220
300	143	378	310	260
350	184	438	360	302
400	140	489	410	355
450	152	539	450	382
500	152	617	505	435
600	178	734	624	536

Check Valve Installation

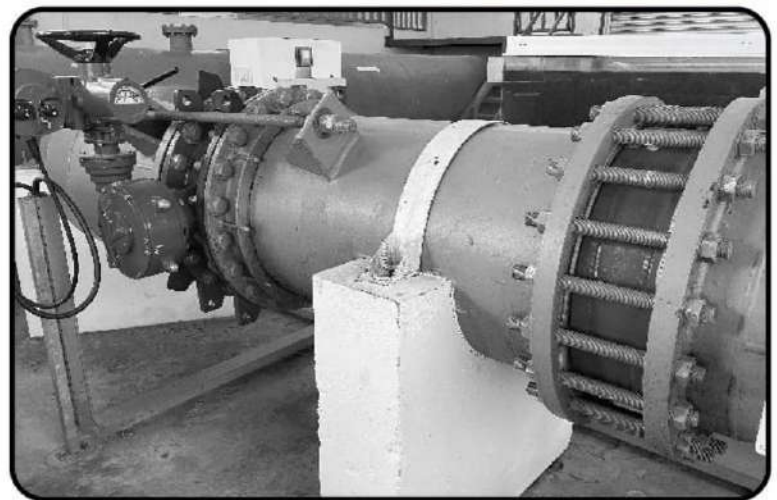

Wafer Type Design Fits between Two Pipe Flanges

Note: Technical data provided in this brochure is indicative only and may be subject to change without prior notice.