



ROSE STRAINER WITH STAINLESS STEEL BASKET



NORWARDS INDUSTRIES SDN. BHD.

(Company Reg. No.: 442356-M)

ROSE STRAINER WITH STAINLESS STEEL BASKET

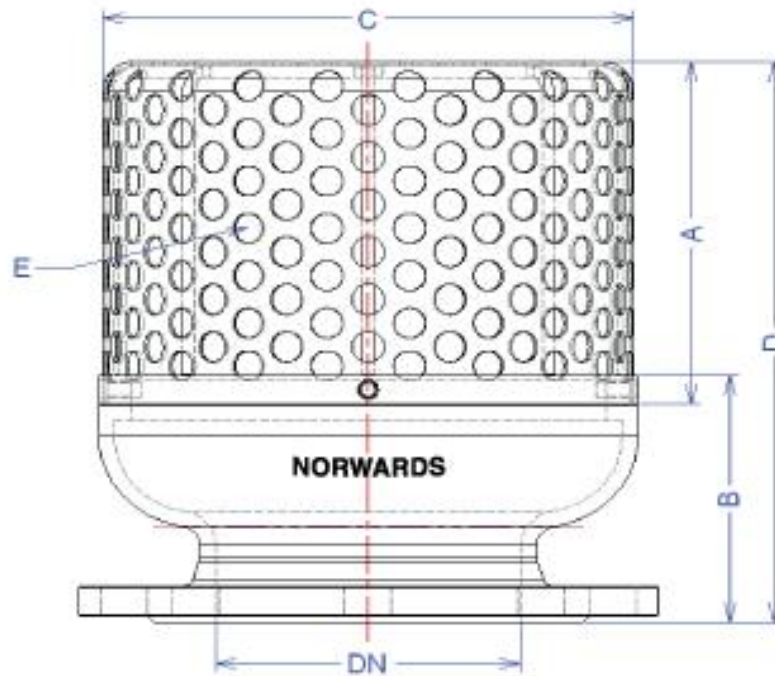

PN 16 FLANGE

Dimension (Unit): mm

Nominal Size (DN)	A (mm)	B (mm)	C (mm)	D (mm)	E (mm)	Weight (kg)
100	100	110	190	185	16	12
150	150	125	230	250	16	15
200	200	145	280	320	16	20
250	250	150	360	375	16	27
300	300	170	395	445	25	35
350	350	180	465	505	25	44
400	400	185	550	560	25	53
450	450	190	610	615	25	65
500	500	200	680	675	25	104
600	600	210	800	785	25	165
700	700	230	860	905	25	200
800	800	250	980	1025	25	230

Material Specification:

- Base** : Ductile Iron to BS EN 545
- Basket** : Stainless Steel 304
- Bolt & Nuts** : Stainless Steel BS 970 Part 4 304S31
- Coating** : Fusion Bonded Epoxy AS NZ S4158:1
: Cold Applied High Liquid Epoxy Coating
AWWA C210-84
: Black Bitumen BS 3416
- Flange** : Drill to 4504 PN 16

DISTRIBUTED BY:

