



微信公众平台：海利普变频器



HLP-C100 Series Operating Manual





HLP-C100 Series Operating Manual

Index

Introduction	I
Chapter 1 Safety Precautions	1
1.1 Before power-up	- 1 -
1.2 During the power-up	- 2 -
1.3 During the operation	- 3 -
1.4 After the power-off	- 3 -
Chapter 2 Standards and Specifications	- 4 -
2.1 Label Description	- 4 -
2.2 Particular specifications	- 5 -
2.3 Technical specifications	- 5 -
Chapter 3 Installation and Wiring	- 8 -
3.1 Checks before Installation	- 8 -
3.2 Installation dimensions	- 8 -
3.2.1 Dimensions of the Inverter	- 8 -
3.2.2 Dimensions of the inverter	- 9 -
3.3 Installation and Wiring	- 9 -
3.3.1 Electrical Installation in General	- 10 -
3.3.2 Fuse Specifications	- 10 -
3.3.3 Installation and Direction	- 11 -
3.3.4 Wiring terminal	- 13 -
3.3.5 Wiring	- 14 -
Chapter 4 Operation and Display Interface	- 14 -
4.1 LCP Digital Operator	- 14 -
4.2 Quick to set parameters	- 14 -
4.2.1 Preset reference by LCP	- 15 -
4.2.2 FWD/REV Status	- 16 -
4.2.3 Data Read-outs	- 17 -
4.2.4 View alarm record	- 18 -
4.2.5 View state parameter	- 20 -
4.2.6 LED Display	- 21 -
Chapter 5 Quick Application Guide	- 21 -
5.1 Parameter initialization	- 21 -
5.2 Using LCP to control the drive [HAND]	- 21 -
5.3 Using digital in terminals to control the drive [AUTO]	- 21 -
5.4 Forward, Reverse and Jog	- 21 -
5.5 Multi-speed	- 22 -
Chapter 6 Parameter Overview	- 23 -

Chapter 7 Parameter Description	- 33 -
7.1 Parameter group 00: operation/display	- 33 -
7.2 Parameter group 01: load and motor	- 35 -
7.3 Parameter group 02: brakes	- 39 -
7.4 Parameter group 03: reference/ramps	- 41 -
7.5 Parameter group 04: limits/warnings	- 51 -
7.6 Parameter group 05: digital input/output	- 54 -
7.7 Parameter group 06: analog in/out	- 55 -
7.8 Parameter group 07: controller	- 59 -
7.9 Parameter group 08: comm. and options	- 60 -
7.10 Parameter group 14: special functions	- 62 -
7.11 Parameter group 15: drive information	- 65 -
7.12 Parameter group 16: data readouts	- 67 -
Chapter 8 Accessory Specification	- 72 -
8.1 Braking resistor	- 72 -
8.2 LCP Mounting Kit	- 72 -
8.2.1 External LCP Communication Cable	- 72 -
8.2.2 Mounting steps	
Chapter 9 EMC	- 73 -
9.1 EMC—Correct Installation	- 73 -
9.2 RFI Switch	- 73 -
Chapter 10 Warnings/Alarms and Fault Handling	- 74 -
10.1 Fault list	- 74 -
10.2 Fault indication and trouble shooting	- 76 -
Chapter 11 Maintenance	- 78 -
11.1 Note	- 78 -
11.2 Storage and transport	- 78 -
Chapter 12 Communication protocol	- 79 -
12.1 Format specification	- 79 -
12.2 Coil addressing	- 79 -
12.3 Read coil status	- 81 -
12.4 Read holding registers	- 82 -
12.4 Force single coil	- 82 -
12.5 Preset single register	- 83 -
12.6 Force multiple coils	- 84 -
12.7 Preset multiple regs	- 85 -
12.8 Read/write array	- 85 -
12.9 Exception code	- 87 -

Chapter 1 Safety Precautions



Caution Indicates misuse may damage the inverter or mechanical system .



Danger Misuse may result in casualty.

1.1 Before power-up

Caution

- Check to be sure that the voltage of the main circuit AC power supply matches the input voltage of the inverter.
- Install the inverter in a safe location, avoiding high temperature, direct sunlight, humid air or water.
- The inverter can only be used at the places accredited by our company. Any unauthorized working environment may have the risks of fire, gas explosion, electric shock and other incidents.
- If more than one drive installed on the same control cabinet, make additional cooling fan, so that the inside temperature is lower than 40 in order to prevent overheating or fire occurs.
- It will affect the service life of the inverter if a contactor is installed on the input side to control the start and stop. Generally it is required to control it through terminal commands. Special attention should be paid to its use in the case of the start and stop more frequently places.
- Do not install any switch component like circuit breaker or contactor at the output of the inverter. If any of such components must be installed due process and other needs, it must be ensured that the inverter has no output when the switch acts. In addition, it is forbidden to install any capacitor for improvement of power factor or any varistor against thunder at the output. Otherwise it will cause malfunctions, tripping protection and damages of components of the inverter.
- Please use an independent power supply for the inverter. Do avoid using the common power supply with an electrical welder and other equipment with strong disturbance. Otherwise it will cause the drive to protect or even damage the drive.
- Do not make any high voltage test with any component inside the inverter. These semi-conductor parts are subject to the damage of

high voltage.

- The IC board of the inverter are susceptible to the effect and damage of static electricity. Don't touch the main circuit board.
- Installation, commissioning and maintenance must be performed by qualified professional personnel.
- It should be handled with the base to avoid the dropping of the inverter, which may possibly cause the injuries to people and the damages to the inverter.

 **Danger**

- Be sure to turn off the power supply before wiring.
- Mount the drive in the metal and other non-combustible materials to avoid the risk of fire.
- Don't install the drive in a space with explosive gas, otherwise, they lead to explosion.
- R, S, T terminals are power input terminals, never mixed with U.V.W terminals. Be sure that the wiring of the main circuit is correct. Otherwise it will cause damages of the inverter when the power is applied to it.
- The terminal of ⊕ must be grounded separately and never connected to N-line. Otherwise it will easily cause the protection or errors of the inverter.
- Do not disassemble or modify any internal connecting cord, wiring or component of the inverter by yourself.
- Never remodel it or exchange control boards and components by yourself. It may expose you to an electrical shock or explosion, etc.
- Keep the inverter from the reach of children or persons not concerned.

1.2 During the power-up

 **Danger**

- Do not plug the connectors of the inverter during the power up to avoid any surge into the main control board due to plugging, which might cause the damage of the inverter.

1.3 During the operation

 **Caution**

- Do not measure the signals on circuit boards while the inverter is running to avoid danger.
- The drive has been optimized before sold. Please make proper adjustments according to the desired functions.
- Do consider the vibration, noise and the speed limit of the motor bearings and the mechanical devices.

 **Danger**

- Never connect or disconnect the motor set while the inverter is in running. Otherwise it will cause over-current trip and even burn up the main circuit of the inverter.
- Never remove the front cover of the inverter while the inverter is powered up to avoid any injury of electric shock.
- Do not come close to the machine when the Reset Function is used to avoid anything unexpected. The motor may automatically recover from fault.

1.4 After the power-off

 **Caution**

- Even in the case of the main power, the other voltage inputs and the share load (linkage of DC intermediate circuit) all have been disconnected from the mains; the internal of the drive may still have residual energy. Before touching any potentially live parts of the inverter, please wait at least 4 minutes. Otherwise, it may expose you to a risk of electrical shock.

The user must strictly follow the instruction to operate and make wire connection. Otherwise HOLIP will not responsible for the damages due to wrong operation. The user will responsible for the damages themselves.

Chapter 2 Standards and Specifications

2.1 Label Description



Significance of the type code:

T/C: HLP-C1000D3721P20XXX1CX0AXXVXXX

	1-8	9-12	13-14	15-17	18-20	21	22	23	24	25	26-27	28-31
1-8	HLP-C100											
9-12	0D37											
13-14	21											
	23											
	43											
15-17	P20											
18	X											
	A											
19	X											
	B											
20	X											
	B											
21	1											
22	C											
23	X											
24	0											
	1											
25	A											
	B											
26-27	XX											
28-31	VXXX											

2.2 Particular Specifications

Model	Input voltage	Input current/ A	Output current/ A	Rated power/ KW	Suitable motor/ KW	Net weight/ KG
HLP-CI000D372I	1×200-240V50/60HZ	61	2.2	0.37	0.37	0.84
HLP-CI000D752I	1×200-240V50/60HZ	11.6	4.2	0.75	0.75	0.84
HLP-CI000ID52I	1×200-240V50/60HZ	18.7	6.8	1.5	1.5	0.84
HLP-CI000D3723	3×200-240V50/60HZ	3.5	2.2	0.37	0.37	0.84
HLP-CI000D7523	3×200-240V50/60HZ	6.7	4.2	0.75	0.75	0.84
HLP-CI000ID523	3×200-240V50/60HZ	10.9	6.8	1.5	1.5	0.84
HLP-CI000D7543	3×380-440V50/60HZ	3.5	2.2	0.75	0.75	0.84
	3×440-480V50/60HZ	3.0	2.1			
HLP-CI000ID543	3×380-440V50/60HZ	5.9	3.7	1.5	1.5	0.84
	3×440-480V50/60HZ	5.1	3.4			
HLP-CI0002D243	3×380-440V50/60HZ	8.5	5.3	2.2	2.2	0.84
	3×440-480V50/60HZ	7.3	4.8			

2.3 Technical Specifications

Item		Specification
Power supply	Supply voltage	single/three phase 220V ±20%; three phase 380V ±20%;
	Frequency	48-62Hz;
	Max. imbalance	3%;
Motor output	Output voltage	three phase 0-100% of supply voltage;
	Output frequency	0-400Hz
Main control functions	Control mode	V/F
	Start torque	0.5Hz 150%;
	Overload capacity	150% rated output current (60s)
	PWM switch frequency	2K-16KHz
	Speed setting resolution	Digital: 0.001Hz; analogy: 0.5‰ of the max. operating frequency ;
	Control command source	LCP , digital terminal, local bus;
	Frequency setting source	LCP , analog, local bus;
Ramp control	Selectable 8-speed steps;	

Item	Specification			
Basic Functions	Automatic Voltage Regulation; V/F Control, DC Brake; Speed Limit; Current Limit; Reset Function; Timer; PI Controller.			
Application Functions	Speed Open-loop Control; Process Closed-loop Control; Jogging ; Multi-speed Control via Digital input; Deferent speed with deferent ramp; Mechanical Braking; Catch up / Slow down; Relative Scaling Reference; Recover user settings by a key etc.			
Protection Functions	Missing Motor Phase Protection; Low-voltage Protection; Over-voltage Protection; Over-current Protection; Output Phase Loss Protection; Output Short Circuit Protection; Output Grounding Fault Protection; Motor Thermal Protection; CPU Fault; EEPROM Faults; Button freeze; Duplicate Fails; LCP Invalid; LCP Incompatible; Parameter Read-only; Reference Out of Range; Invalid While Running; Password Error etc.			
Control Terminals	Digital input	Number	5 digital inputs.	
		Scanning time	1ms;	
	Analog input	Number of input	1 analog inputs(VI), both can receive voltage or current signals.	
		Input accuracy	Max.error: 0.5% of full scale	
		Resolution	11bit;	
		Scanning time	1ms;	
	Digital output	Relay output	1 relay outputs (FA-FB-FC);	
		Scanning time	1ms;	
	Power supply	+10V	10VDC power supply;	
	RS485 serial communication	Terminal number	1, RS+(TX+,RX+), RS-(TX-, RX-);	
Ground for RS485		COM;		

Item		Specification
Display	8 segments, 5 numeric displays	Display frequency, warnings, status and so on;
	Indicator	Light FWD, REV, HZ, A, R/MIN display various status of the inverter;
	Data read-outs	Frequency setting, output frequency, feedback value, output current, DC link voltage, output voltage, output power, input terminals state, output terminals state, analogue input, I-10 fault records and accumulated working time etc.;
Accessory	Remote mounting kit	Available when the control panel for external use;
	Copy card	Copy parameters from one inverter to another ;
Environment	Enclosure	IP20;
	Ambient temperature	-10 -40 ;
	Humidity	5%-85% (95% without condensation) ;
	Vibration test	114g;
	Max. altitude above sea level	1000m, derating use when more than 1000 meters;
	Motor cable length	Shield cable: 5 meters, unshield cable: 50 meters;

Attention: Inverter under special environment (derating):

- Derating for ambient temperature: If the frequency converter is operated over 40 ambient temperature, the continuous output current should be decreased. The frequency converter has been designed for operation at max 50 ambient temperature with one motor size smaller than normal. Continuous operation at full load at 50 ambient temperature will reduce the lifetime of the frequency converter.
- Derating for low air pressure: The cooling capability of air is decreased at low air pressure. Below 1000m altitude no de-rating is necessary but above 1000m the ambient temperature or the maximum output current should be decreased. Decrease the output by 1% per 100m altitude above 1000m or reduce the max. ambient temperature by 1 degree per 200m.

Chapter 3 Installation and wiring

3.1 Checks before Installation

The inverter has been strictly and well packed before sold. In consideration of various factors during the transportation special attention should be paid to the following points before installation. If there is anything abnormal please notify the dealer or the relevant people of our company.

- Check if the inverter has got any damage or deformation during the transportation and handling;
- Check if there is one piece of HLP-C100 series inverter and one copy of the quick guide available when unpacking it;
- Check the information on the label to see if the specifications meet your order (Operating voltage and KW value);
- Check if there is a certificate of qualification and a warranty card.

3.2 Installation Dimensions

3.2.1 Dimensions of LCP

Dimensions of the LCP are shown below(unit:mm)

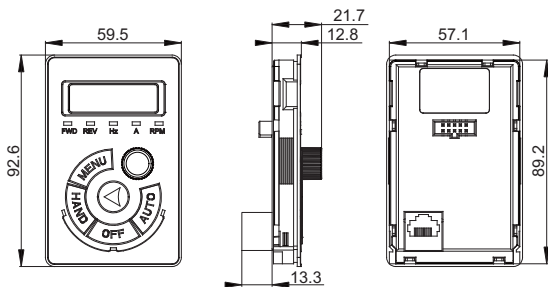

3.2.2 Dimensions of the inverter

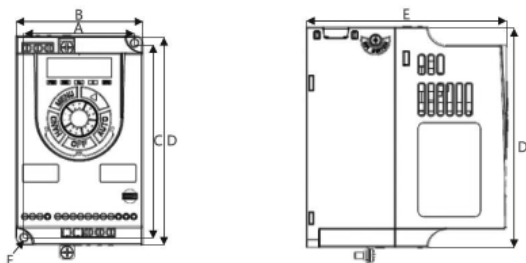

Power(kW)			A	B	C	D	E	F
1×200-240V	3×200-240V	3×380-480V	mm	mm	mm	mm	mm	mm
0.37-1.5	0.37-1.5	0.75-2.2	74	85	130	140	127	Φ5

3.3 Installation and Wiring

3.3.1 Electrical Installation in General

⚠ Caution

- All cabling must comply with national and local regulations on cable cross-sections and ambient temperature. Copper conductors required, and ambient temperature(60-75) recommended.

Details of terminal tightening torques :

Power(KW)and Voltage levels			Torque(Nm)				
1×200-240V	3×200-240V	3×380-480V	Line	Motor	DC connection/ Brake	Control terminals	Relay
0.37-1.5	0.37-1.5	0.75-2.2	14	08	08	015-0.4	0.4

3.3.2 Fuse Specifications

Model	Fuse size (Rated current/A)
HLP-C1000D3721	10
HLP-C1000D7521	25
HLP-C1000D521	32
HLP-C1000D3723	10
HLP-C1000D7523	16
HLP-C1000D523	25
HLP-C1000D7543	10
HLP-C1000D543	10
HLP-C10002D243	16

3.3.3 Installation and Direction

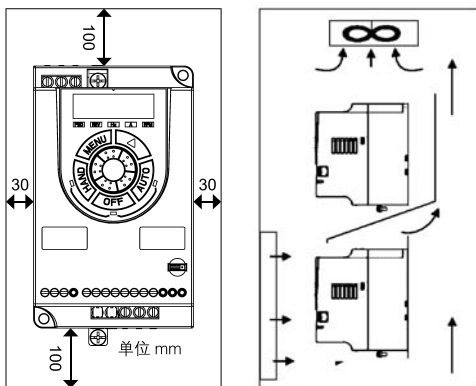

Note: Install the unit and make sure that it is free from high moisture, high temperature, heavy dust, metal fragments and high oil mist.

3.3.4 Wiring terminal

3.3.4.1 Main Circuit Terminals

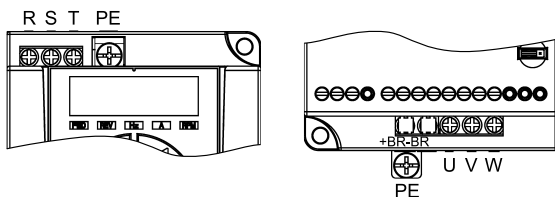

Description of main circuit terminals:

Symbol	Function
R, S, T	Power input: 220V class 1- phase 200-240V50/60Hz 3- phase 200-240V50/60Hz 380V class 3- phase 380-480V50/60Hz Single phase connected to R, T
U, V, W	Power output, connect to the motor
-BR, +BR	Connect the brake resistor, make sure to set C02.I0, C02.II etc.
PE	Ground terminal

3.3.4.2 I/O Control Terminals

FA	FB	FC	FOR	REV	DI1	DI2	DI3	GND	+10V	VI	RS+	RS-	COM
----	----	----	-----	-----	-----	-----	-----	-----	------	----	-----	-----	-----

Description of I/O control terminals:

Symbol	Description	Specification
Relay output (FA-FB-FC)	Relay output	1 Resistive load: 250VAC 3A/30VDC 3A; 2 Inductive load: 250VAC 0.2A/24VDC 0.1A ($\cos\phi=0.4$); 3 FA FB normally closed, FB FC normally open;
Digital input (FOR, REV, DI1, DI2, DI3)	Digital control terminals	1 Logic: >DC19V logic '0'; <DC14V logic '1'; 2 Voltage: DC 0-24V;
GND	Digital or Analog ground	Isolated from internal COM;
+10V	10V power supply	Max.load 25 mA, with over load and short circuit protection functions;
Analog input (VI)	Analog setting/ Feedback	Set by the related parameter, analog input channel can be configured to 0-20mA or 0-10V : Voltage input: 1 Input impedance: about 10 K Ω ; 2 Maximum withstand voltage is 20V, duration of 2 seconds, the maximum reverse voltage is -15V, duration of 2seconds. Current input: 1 Input impedance \leq 500 Ω ; 2 Maximum withstand current is 29 mA duration of 2 seconds.
RS+, RS-	RS485 communication	RS485 + and RS485- ;
COM	Ground for communication	Isolated from internal GND;

Note: Only the machine with RS485 (type code number 25 is B) has RS+ RS- and COM;

3.3.5 Wiring

Basic Connection Diagram of HLP-C100 series inverter:

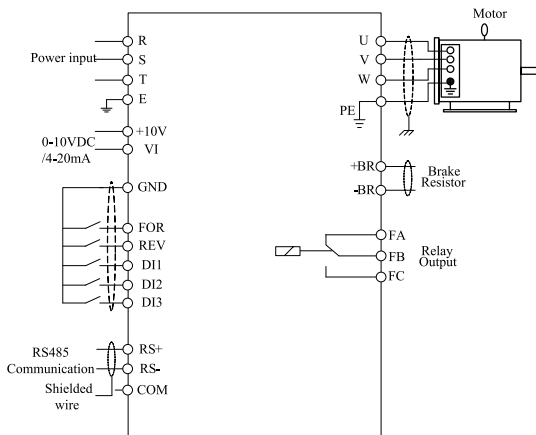

Precautions for the main circuit wiring:

- While wiring the sizes and specifications of wires should be selected and the wiring should be executed according to the electrical engineering regulations to ensure the safety.
- It is better to use shielded wire or wire conduit for power cord and ground the shielded layer or two ends of wire conduit.
- Be sure to install a circuit Breaker between the power supply and the input terminals (R,S,T). (If using RCD, please choose B type)
- Phase-shifting capacitors, LC, RC noise filters etc, can never be connected to the output terminals of the inverter.
- Please lower the inverter switching frequency when there is a longer distance between the inverter and the motor.
- Drive earth leakage current is greater more than 35 mA. According to the requirements of IEC 61800-5-1, must use the following ways to enhance the protection of ground: minimum 10mm² cross sectional area of copper, or additional PE line, its cross sectional area and the main power cable should be the same, must be separate grounded.
- Make sure reliable ground of the inverter in accordance with IEC 61800-5-1.
- Please refer to 9.2 for the use of RFI SWITCH.

Chapter 4 Operation and Display Interface



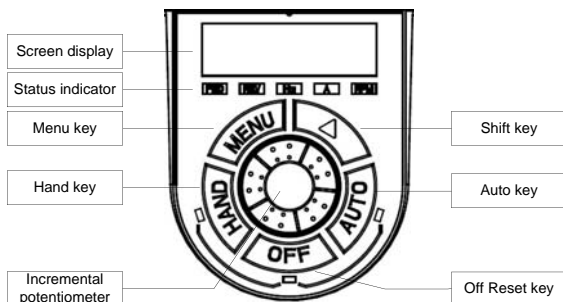







4.1 LCP Digital Operator













4.2 Quick to set parameters

4.2.1 Preset reference by LCP





Example: Set a reference to 0.25 That is C0310 [0] = 20.5:





Key-press	LCP Display	Action Description
	C00.04	Press  key to display the first basic C00.03
	C03.00	Turn  clockwise to select parameter group C03
	C03.00	Press  key to shift to fractional part
	C0310	Turn  clockwise to select parameter C0310
	[0]	Press  to show the first option of C0310

Key-press	LCP Display	Action Description
	0000	Press  to show the value of the first option of parameter C03I0
	000.5	Turn  clockwise to change the fractional part to 5
	000.5	Press  key to shift to integral part
	020.5	Turn  clockwise to change the integral part to 20
	END	Press  to accept the change and save it as 20.5

4.2.2 FWD/REV Status

Confirm the direction of the motor according to the set value, as shown in the following table:

Reference	Running status	Indicator Display
0	STOP	 FWD REV
< 0	STOP	 FWD REV
0	FWD	 FWD REV
0	REV	 FWD REV









Reference	Running status	Indicator Display
< 0	FWD	  FWD REV
> 0	REV	  FWD REV

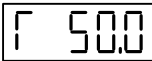

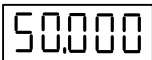

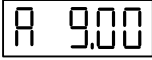

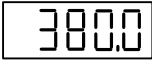

Note: A flash light denotes the status coming, Light on indicates the current state, and light off means not in this state.

Example 1: The first line of the table indicates the drive is stop and the reference is greater than or equal to 0, means the drive at some time in the future will run forward.

Example 2: The fourth line of the table represents the current drive is reverse running, and the reference setting is greater than or equal to 0, it means the drive at some time in the future will run forward.

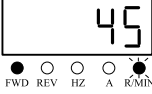
4.2.3 Data Read-outs

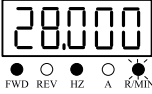

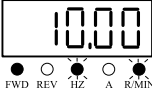
Display Items	Key-press	LCP Display	Action Description
Output Frequency	Initial interface	 	Show the output frequency (Cl613) is 50.0Hz, display accuracy: 0.1
Reference (%)		 	Show the preset reference (Cl6.01) is 50%, display accuracy: 0.001
Motor Current		 	Show the motor current (Cl614) is 900A, display accuracy: 0.01
Motor Voltage		 	Show the motor voltage (Cl612) is 380.0V, display accuracy: 0.1













Display Items	Key-press	LCP Display	Action Description
Motor Speed			Show the motor speed (C16.05) is 1440rpm, display accuracy:1
DC Voltage			Show the DC voltage(C16.30) is 540.0V, display accuracy: 0.1
Inverter temperature			Show the inverter temperature (parC16.34) is 45 , display accuracy:1
Feedback Value			Show the feedback value(C16.52) is 28.000, display accuracy: 0.001
Analog in VI			Show analog in VI (C16.62) is 10.00V, display accuracy: 0.01

Note: Press  key to change the display items on control panel, however, C00.33 must be activated (see C00.33).

4.2.4 View alarm record



If the drive trips, fault code will be showed to illustrate the reason, all the trip record will be saved.













Key-press	LCP Display	Action Description
	C00.04	Press  key to display the first basic C00.03.

Key-press	LCP Display	Action Description
	C15.00	Turn  clockwise to select par. group No. C15.
	C15.00	Press  to select parameter number.
	C15.30	Turn  clockwise to select C15.30
	[0]	Press  to show the first option of C15.30
	**	Press  to show the first fault record.
	[]	Press  to show the second fault record, it can display up to ten recent fault records in turn.



































































4.2.5 View state parameter

View the status of input terminal, reference, feedback value, output frequency, output current, output voltage, and the power etc.

Key-press	LCP Display	Action Description
	C00.03	Press  to display the first basic parameter C00.03.

Key-press	LCP Display	Action Description
	Cl6.00	Turn  clockwise to select Par. group No. Cl6
	Cl6.00	Press  to select parameter No.
	Cl6.0l	Press  select Cl6.0l
	0	Turn  clockwise to finish browse value of Cl6.0l.
	Cl6.60	Press  to select Cl6.60.
	0000	Press  to view the value in Cl6.60, 0l00 indicates status of FOR, DI1, DI2 is 0, and status of REV is 1.

4.2.6 LED Display

0	1	2	3	4	5	6	7	8	9
									
A	B	C	D	E	F	G	H	I	J
									
K	L	M	N	O	P	Q	R	S	T
									
U	V	W	X	Y	Z	-	+	.	=
									
a	b	c	d	e	f	g	h	i	j
									
k	l	m	n	o	p	q	r	s	t
									
u	v	w	x	y	z				
									

Chapter 5 Quick Application Guide

5.1 Parameter initialization

1. Set C1422 = 2
2. Cut off the main power and Re-power on, LCP displays E.80
3. Press “OFF” key on LCP.

5.2 Using LCP to control the drive [HAND]

1. Parameter initialization;
2. Press “HAND” key on LCP;
3. Turn the incremental potentiometer to adjust the frequency;
4. Press “OFF” key on LCP to stop the frequency converter;

5.3 Using digital in terminals to control the drive [AUTO]

1. Parameter initialization;
2. Press “AUTO” key on LCP (Digital control and communication control are only active in auto mode);
3. Frequency source: Preset C0310 or select frequency source by C0315, C0316;
4. Connect digital input terminal FOR and GND to operate the frequency convert;
5. Disconnect the digital input terminal FOR and GND to stop the frequency converter.

5.4 Forward, Reverse and Jog

1. IO terminals connection as following:

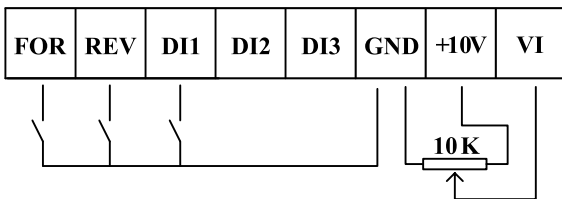

2. Parameter initialization;
3. Set parameter as following:
C0311=10Hz
C0315=1, C0316=0

- C03.4I=0.5, C03.42=0.5, C03.80=0.5, C04.10=2
 C05.1I=1I, C05.13=14
 C06.10=0, C06.1I=10, C06.14=0, C06.15=50
 4. Press "AUTO" key on LCP;

5.5 Multi-speed

1. IO terminals connection as following:

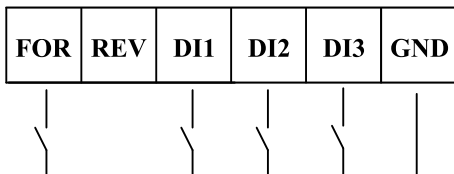

2. Parameter initialization;
 3. Set parameter as following:
 C03.03=50
 C05.10=8, C05.12=15 (Bit0), C05.13=16 (Bit1), C05.13=17 (Bit2)
 C03.10[0]=10 (Speed1=5Hz), C03.10[1]=20 (Speed2=10Hz),
 C03.10[2]=30 (Speed3=15Hz), C03.10[3]=40 (Speed4=20Hz),
 C03.10[4]=50 (Speed5=25Hz), C03.10[5]=60 (Speed6=30Hz),
 C03.10[6]=70 (Speed7=35Hz), C03.10[7]=80 (Speed8=40Hz),
 4. Press "AUTO" key on LCP;

Chapter 6 Parameter Overview

Item	Parameter No.	Function Description	Setting range	Unit	Default setting	Page No.
Parameter Group 00: Operation/Display	C00.04	Operating State at Power-up	0: Resume; 1: Forced stop reference=old; 2: Forced stop reference=0;		1	
	C00.33	LCP Display Option	0-2047		0	
	C00.40	HAND key on LCP	0:Disabled; 1:Enabled;		1	
	C00.41	OFF key on LCP	0:Disable All; 1:Enable All; 2:Enable Reset Only;		1	
	C00.42	AUTO key on LCP	0:Disabled; 1:Enabled;		1	
	C00.60	Menu Password	0:Disabled; 1:Enabled;		0	
Parameter Group 01: Load/motor	C01.00	Configuration Mode	0: Speed open loop; 1: Speed closed loop; 3: Process closed loop;		0	
	*C01.20	Motor Power [kW][HP]	Depon motor date	kW	*	
	*C01.22	Motor Voltage (Um.n)	50~1000	V	*	
	*C01.23	Motor Frequency (fm.n)	20~400	Hz	*	
	*C01.24	Motor Current (Im.n)	Depon motor date	A	*	
	*C01.25	Motor Nominal Speed (nm.n)	100~9999	rpm	*	
	*C01.42	Motor Cable Length	0~150	m	50	
	C01.55	U/F Characteristic-U	0~999	V		
	C01.56	U/F Characteristic-F	0~400	Hz		
	C01.71	Start Delay	0.0~10.0	s	0.0	

Item	Parameter No.	Function Description	Setting range	Unit	Default setting	Page No.
	C0172	Start Function	0: DC hold/delay time; 2: Coast/Delay time;		2	
	*C0173	Flying start	0:Disabled; 1:Enabled;		0	
	C0180	Function at Stop	0: Coast; 1: DC Hold;		0	
	C0182	Min Speed for Function at Stop [Hz]	0.0~200	Hz	0.0	
Parameter Group 02: Brake Function	C02.00	DC Hold Current	0~150	%	50	
	C02.01	DC Brake Current	0~150	%	50	
	C02.02	DC Braking Time	0.0~60.0	s	10.0	
	C02.04	DC Brake Cut In Frequency	0.0~400.0	Hz	0.0	
	C02.10	Brake Function	0: Off; 1: Resistor brake; 2: AC brake;		0	
	C02.11	Brake Resistor (ohm)	Depon motor date	Ω	*	
	C02.17	Over-voltage Control	0: Disabled; 2: Enabled;		0	
Parameter Group 03: Reference/Ramps	C03.03	Maximum Reference	0.000~4999.000		50.000	
	C03.07	Actual reference calculation	0: Preset reference + Reference source 1,2 1: Preset reference priority		0	
	C03.10	Preset Reference	-100.00~100.00	%	0.00	
	C03.11	Jog Speed [Hz]	0.0~400.0	Hz	5.0	
	C03.12	Catch up/slow Down Value	0.00~100.00	%	0.00	

Item	Parameter No.	Function Description	Setting range	Unit	Default setting	Page No.
	C0315	Reference Resource 1	0: No function; 1: Analog input VI; 1f: Local bus ref; 2f: LCP potentiometer;		1	
	C0316	Reference Resource 2			2	
	C0318	Relative Scaling Reference Resource			0	
Parameter Group 03 Reference/Ramps	C0340	Ramp 1 Type	0: Linear; 2: Sine ramp;		0	
	C0341	Ramp 1 Ramp up Time	0.10~300.00	s	*	
	C0342	Ramp 1 Ramp Down Time	0.10~300.00	s	*	
	C0350	Ramp 2 Type	0: Linear; 2: Sine ramp;		0	
	C0351	Ramp 2 Ramp up Time	0.10~300.00	s	*	
	C0352	Ramp 2 Ramp down Time	0.10~300.00	s	*	
	C0360	Ramp 3 Type	0: Linear; 2: Sine ramp;		0	
	C0361	Ramp 3 Ramp up Time	0.05~3600.00	s	*	
	C0362	Ramp 3 Ramp down Time	0.05~3600.00	s	*	
	C0370	Ramp 4 Type	0: Linear; 2: Sine ramp;		0	
	C0371	Ramp 4 Ramp up Time	0.10~300.00	s	*	
	C0372	Ramp 4 Ramp down Time	0.10~300.00	s	*	
	C0380	Jog Ramp Time	0.10~300.00	s	*	
	C0384	Ramp 5 Type	0: Linear; 2: Sine ramp;		0	
	C0385	Ramp 5 Ramp up Time	0.10~300.00	s	*	
C0386	Ramp 5 Ramp down Time	0.10~300.00	s	*		

Item	Parameter No.	Function Description	Setting range	Unit	Default setting	Page No.
	C0387	Ramp 6 Type	0: Linear; 2: Sine ramp;		0	
	C0388	Ramp 6 Ramp up Time	0.10~300.00	s	*	
	C0389	Ramp 6 Ramp down Time	0.10~300.00	s	*	
Parameter Group 03: Reference/Ramps	C0390	Ramp 7 Type	0: Linear; 2: Sine ramp;		0	
	C0391	Ramp 7 Ramp up Time	0.10~300.00	s	*	
	C0392	Ramp 7 Ramp down Time	0.10~300.00	s	*	
	C0393	Ramp 8 Type	0: Linear; 2: Sine ramp;		0	
	C0394	Ramp 8 Ramp up Time	0.10~300.00	s	*	
	C0395	Ramp 8 Ramp down Time	0.10~300.00	s	*	
	C0396	Link preset reference and ramp time	0: No link; 1: Link		0	
Parameter Group 04: Limits/Warnings	*C0410	Motor Speed Direction	0: Clockwise; 1: Counterclockwise; 2: Both;		2	
	*C0412	Motor Speed Low Limit [Hz]	0.0~400.0	Hz	0.0	
	*C0414	Motor Speed High Limit [Hz]	0.0~400.0	Hz	65.0	
	C0418	Current Limit	0~300	%	150	
	*C0419	Max. Output Frequency	0.0~400.0	Hz	65.0	
	C0452	Warning Speed Low	0.0~400.0	Hz	0.0	
	C0453	Warning Speed High	0.1~400.0	Hz	65.0	
	*C0458	Missing Motor Phase Function	0: Off; 1: On;		1	

Item	Parameter No.	Function Description	Setting range	Unit	Default setting	Page No.
	C04.61	Bypass Speed From [Hz]	0.0~400.0	Hz	0.0	
	C04.63	Bypass Speed To [HZ]	0.0~400.0	Hz	0.0	
Parameter Group 05: Digital In/Out	C05.10	Terminal FOR Digital Input	0: No operation; 1: Reset; 2: Coast		8	
	C05.11	Terminal REV Digital Input	inverse; 5: DC-brake inverse; 6: Stop		10	
	C05.12	Terminal DI1 Digital Input	inverse; 8: Start; 10: Reversing; 11: Start		15	
	C05.13	Terminal DI2 Digital Input	reversing; 14: Jog; 15: Preset ref bit0; 16: Preset ref bit1;		16	
	C05.14	Terminal DI3 Digital Input	17: Preset ref bit2; 28: Catch up; 29: Slow down; 34: Ramp bit0; 35: Ramp bit1; 36: Ramp bit2;		17	
	C05.40	Relay Function (FA-FB, FB-FC)	0: No operation; 5: Drive running; 9: Alarm; 10: Alarm or Warning; 15: Out of frequency rang; 16: Below frequency, low; 17: Above frequency, high; 21: Thermal warning; 24: Ready, voltage ok; 25: Reverse; 26: Bus ok; 28: Brake, no brake warning; 53: No alarm; 55: Running reverse;		0	
	C06.10	Terminal VI Low Voltage	0.00~999	V	0.07	
	C06.11	Terminal VI High Voltage	0.10~10.00	V	10.00	
	C06.12	Terminal VI Low Current	0.00~1999	mA	0.14	

Item	Parameter No.	Function Description	Setting range	Unit	Default setting	Page No.
Parameter Group 06: Analog In/Out	C0613	Terminal VI High current	0.01~20.00	mA	20.00	
	C0614	Terminal VI Low Ref./ Feedb.Value	-4999.000~4999.000		0.000	
	C0615	Terminal VI High Ref./ Feedb.Value	-4999.000~4999.000		50.000	
	C0616	Terminal VI Filter Time Contant	0.01~10.00	s	0.01	
	C0618	Terminal VI Zero dead band	0.00~20.00	V/ mA	0.00	
	C0619	Terminal VI Mode	0: Votage mode; 1: Current mode;		0	
	C0681	LCP Potmeter Low Ref.	-4999.000~4999.000		0.000	
	C0682	LCP Potmeter High Ref.	-4999.000~4999.000		50.000	
Parameter Group07: PID Control	C0720	Process CL Feedback Resource	0: No Function; 1: Analog in VI; 1:Local bus;		0	
	C0731	Process PI Anti Windup	0:Disabled; 1:Enabled;		1	
	C0733	Process PI Proportional Gain	0.0~10.00		0.01	
	C0734	Process PI Integral time	0.10~9999.00	s	9999.00	
	C0738	Process PI Feed Forward Factor	0~400	%	0	
	C0739	On Reference Bandwidth	0~200	%	5	
	C0741	Process PI Output Low	-100-100	%	0	
	C0742	Process PI Output High	-100-100	%	100	

Item	Parameter No.	Function Description	Setting range	Unit	Default setting	Page No.
Parameter Group 08: FC Port Settings	C08.01	Control Site	0: Digital and ctrl. word; 1: Digital only; 2: Control Word only;		0	
	C08.02	Control Word Source	0: None; 1: FC RS485;		1	
	C08.03	Control Word Timeout Time	01~6500.0	s	10	
	C08.04	Control Word Timeout Function	0: Off; 1: Freeze output; 2: Stop; 3: Jogging; 4: Max. speed; 5: Stop and trip;		0	
	C08.06	Reset Control Word Timeout	0: No Function; 1: Do Reset;		0	
	C08.31	Address	FC(1~126); MODBUS RTU(1~247);		1	
	C08.32	Port Baud Rate	0: 2400; 1: 4800; 2: 9600; 3: 19200; 4: 38400;		2	
	C08.33	FC Port Parity	0: Even Parity, 1 Stop bit; 1: Odd Parity, 1 Stop bit; 2: No Parity, 1 Stop bit; 3: No Parity, 2 Stop bits;		0	
	C08.35	Minimum Response Delay	0.001~0.500	s	0.010	
	C08.36	Max. Response Delay	0.010~10.000	s	5.000	
	C08.94	Bus Feedback 1	-32768~32767		0	
	C14.01	Switching Frequency	2~6: 2kHz~6kHz; 7: 8kHz; 8: 10 kHz; 9: 12kHz; 10: 16kHz;		5	
	*C14.03	Over modulation	0: Off; 1: On;		1	
	C14.08	Damping Gain Factor	0~200	%	96	

Item	Parameter No.	Function Description	Setting range	Unit	Default setting	Page No.
Parameter Group 14: Special Functions	CI4.12	Function at Mains Imbalance	0: Trip; 1: Warning; 2: Disabled;		0	
	CI4.20	Reset Mode	0: Manual reset; 1~10: Automatic reset x 1~10; 11: Automatic reset x 15; 12: Automatic reset x 20; 13: Infinite auto reset;		0	
	CI4.21	Automatic Restart Time	0~600	s	10	
	CI4.22	Operation Mode	0: Normal Operation; 2: Initialisation; 3: Backup user settings; 4: Recover user settings;		0	
	CI4.23	Trip Lock	0: Disable, Trip lock fault reset do not need power off 1: enable, Trip lock fault reset need power off		1	
	*CI4.51	DC-Link Voltage Compensation	0: Off; 1: On;		0	
Parameter Group 15: Drive Information	CI5.00	Operating Days	0~9999	d		
	CI5.02	KWh Counter	0~65535			
	CI5.03	Power ups	0~2147483647			
	CI5.06	Reset KWh Counter	0: Do not reset; 1: Reset Counter;			
	CI5.30	Fault Log: Error Code	0~255			
	CI5.31	Internal Fault Reason	-32767~32767			
	CI5.40	FC Type	View FC type			
	CI5.41	Power Section	View power size of the drive			

Item	Parameter No.	Function Description	Setting range	Unit	Default setting	Page No.
	CI5.42	Voltage	View Mains Voltage of the drive			
	CI5.43	Software Version	View the software version			
	CI5.44	Ordered Type Code	View the ordered type code of the drive			
Parameter Group I5: Drive Information	CI5.46	Frequency converter ordering NO.	View frequency converter ordering NO.			
	CI5.47	Power Card Ordering NO.	View power card ordering No. of the drive			
	CI5.48	LCP ID NO.	View LCP ID NO.			
	CI5.49	Software ID Control Card	View software ID control card			
	CI5.50	Software ID Power Card	View software ID Power card			
	CI5.51	Frequency Converter Serial Number	View frequency converter No.			
	CI5.53	Power Card Serial number	View power card serial number			
	CI5.92	Parameter List	View parameter list of the drive			

Item	Parameter No.	Function Description	Setting range	Unit	Default setting	Page No.
Parameter Group I6 Data Readouts	Cl6.00	Control Word	0~65535			
	Cl6.01	Reference [Unit]	-4999.000~4999.000			
	Cl6.05	Motor Speed [RPM]	0~9999	Hz		
	Cl6.10	Power[KW]	0.000~1000.000	kW		
	Cl6.12	Motor Voltage	0.0~65535	V		
	Cl6.13	Frequency	0.0~400.0	Hz		
	Cl6.14	Motor Current	0.00~655.35	A		
	Cl6.30	DC Link Voltage	0~65535	V		
	Cl6.34	Heat sink Temp.	0~255			
	Cl6.52	Feedback # [Unit]	-4999.000~4999.000			
	Cl6.60	Digital Input	0~65535			
	Cl6.62	Analog Input VI	0.000-20.000	V/ mA		
	Cl6.71	Relay Output [bin]	0~65535			
	Cl6.86	FC Port REF	-32768~32767			
	Cl6.90	Alarm Word	0~0xFFFFFFFFUL			
	Cl6.91	Alarm Word 2	0~0xFFFFFFFFUL			
	Cl6.92	Warning Word	0~0x7FFFFFFFUL			
	Cl6.93	Warning Word 2	0~0x7FFFFFFFUL			

Note: Reference signed with “*” in parameter No. column means this parameter can't be modified when the motor is running. In factory setting column, “*” means the default setting for this parameter is determined by the drive type.

Chapter 7 Parameter Description

7.1 Parameter Group 00: Operation/Display

C00.0* Basic Settings

C00.04	Function Description	Range	Unit	Default Setting
	Operaton State at Power-up(Hand)	0~2		1

Option: [0] Resume, local reference is stored and used after power up;
 [1] Forced stop, ref=old, local reference is stored and used after power up;
 [2] Forced stop, ref=0, local reference is set to 0;

Function: This parameter is used to control whether or not the frequency converter should automatic running the motor when powering up after a power down in Hand mode.

Description of choice: When select “[0]”, frequency converter starts in same Hand mode roof state as when powered off; When select “[1]”, frequency converter powers up in off state meaning that motor is stopped after power up; When select “[2]”, frequency converter powers up in off state meaning that motor is stopped after power up. Local reference is set to 0. Thus motor will not start running before local reference has been increased.

C00.3* LCP Readout

C00.33	Function Description	Range	Unit	Default Setting
	LCP Display Option	0~2047		0

Description of the choice: LCP will be fixed to display the output frequency, reference and motor current. This parameter is used to show ll basic operating states of the inverter, each parameter corresponds to a binary code: “1” means display the item, “0” means does not display the item. For example, if you want to display the states of the temperature and the terminal VI on LCP. Transform the binary code to decimal digit, $C0033=1 \times 2^3 + 1 \times 2^4 = 24$.

Reserved	Reserved	Reserved	Reserved	Reserved	Reserved	VI Input	Temperature	DC-voltage	Motor Speed	Motor Voltage
0	0	0	0	0	0	1	1	0	0	0

C00.4* LCP Keypad

C00.40	Function Description	Range	Unit	Default Setting
	HAND Key on LCP	0~1		1

Option: [0] Disabled: Hand key has no function;

[1] Enabled: Hand key is functional;

Description of the choice: The frequency converter can operate in the following three mode: HAND, OFF and AUTO. When running in Hand mode, the frequency converter is locally operated and does not allow any remote control. By activating hand a start signal is given.

C00.41	Function Description	Range	Unit	Default Setting
	OFF Key on LCP	0~2		1

Option: [0] Disabled, OFF key has no function;

[1] Enabled, OFF key stop signal and reset of any fault;

[2] Enabled reset only, reset only (fault), stop (off) function is disabled;

Description of the choice: When OFF key is chosen, the frequency converter stops with a normal stop ramp; it can only be started by pressing either hand or auto key on the LCP.

C00.42	Function Description	Range	Unit	Default Setting
	AUTO Key on LCP	0~1		1

Option: [0] Disabled, Auto-on key has no function;

[1] Enabled, Auto-on key is functional;

Description of the choice: In auto-mode, the frequency can be remote controlled (bus/digital).

C00.6* Protection

C00.60	Function Description	Range	Unit	Default Setting
	Menu Password	0~1		

Option: [0] Disabled;

[1] Enabled, none of parameter can be changed except this;

Function: This feature used to prevent non-commissioning person to change the parameter settings.

Attention: Main Menu Password function is only valid to LCP, not active to local bus.

7.2 Parameter Group 01: Load and Motor

C0L0* General Settings

*C01.00	Function Description	Range	Unit	Default Setting
	Configuration Mode	0~3		0

Option: [0] Speed open loop, for general applications;
 [3] Process closed loop, feedback signal is a process unit, such as pressure, temperature etc. When process closed loop is selected, the motor can only run clockwise. For detailed parameter settings, please refer to C073*.

Attention: If configuration mode is changed, C0303 will be restored to factory setting.

C0L2* Motor Date

Attention: Data of Parameter group C0L2* can not be changed when motor is running

*C01.20	Function Description	Range	Unit	Default Setting
	Motor Power	Dep. Motor date	KW	*

Function: Select the KW value that corresponds to the rated power of the motor.

Description of choice: Factory settings depend on the inverter size, there is one or two undersize or one oversize in comparison with factory setting.

Attention: Changing the value of this parameter affects the setting of C0L22-C0L25.

*C01.22	Function Description	Range	Unit	Default Setting
	Motor Voltage	50~1000	V	*

Function: Select a value that equals the nameplate data on the motor.

Description of choice: Default setting depends on the inverter size.

*C01.23	Function Description	Range	Unit	Default Setting
	Motor Frequency	20~400	Hz	*

Function: Enter the rated motor frequency from the nameplate data.

Description of the choice: Default setting depends on the inverter size.

Attention: Changing this parameter affects motor nominal speed set in C0L25.

*C01.24	Function Description	Range	Unit	Default Setting
	Motor Current	Dep. motor data	A	*

Function: Enter motor current value from nameplate data.

Description of the choice: Factory settings depend on the unit size.

*C01.25	Function Description	Range	Unit	Default Setting
	Motor Norminal Speed	100~9999	RPM	*

Function: Enter the motor nominal speed value from the nameplate data.

Description of the choice: Factory setting depends on the unit size.

Attention: If motor frequency has been changed in C0L23, Nominal Motor Speed will be affected.

C0L4* Motor Cable Length

*C01.42	Function Description	Range	Unit	Default Setting
	Motor Cable Length	0~150	m	5

Function: Enter the motor cable length connected between the motor and the frequency converter.

Description of the choice: Set correct cable length can suppress noises resulted from the motor.

C0L5* Load Indep.Setting

C01.55	Function Description	Range	Unit	Default Setting
	V/F Characteristic-V	0~999.9	V	0/Vn

Function: This parameter is an array parameter [0-5], used for setting voltage [V0-V5] at each frequency point to manually form a V/F characteristic matching motor. Frequency points are defined in par. C0L56, V/F characteristics - F.

Description of choice: This parameter is only functional when par. C0L01, Motor Control Principle is set to V/F [0].

Attention: V0 factory setting is set to 0V, and U1-U5 factory setting is set to Un (motor rated voltage).

C01.56	Function Description	Range	Unit	Default Setting
	V/F Characteristic-F	0~400	Hz	0/Fn

Function: This parameter is an array parameter [0-5], used for setting frequency points [F0-F5] to manually form a V/F characteristic matching motor. Voltage at each point is defined in par. C0L55, V/F

Characteristic - V.

Description of choice: This parameter is only functional when par. C0101 Motor Control Principle is set to V/F [0].

Attention: F0 factory setting is set to 0Hz, and F1-F5 factory setting is set to F_n (Motor rated frequency); for par. C0156 the following applies F0=0 and F1<F2<F3<F4<F5.

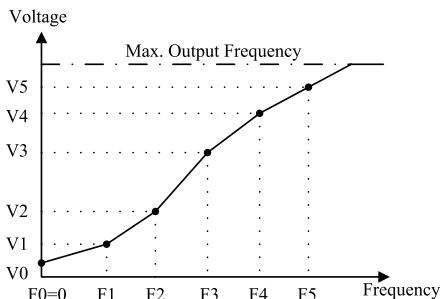

Fig. 61 V/F characteristic diagram

Simplify V/F characteristic by merging 2 or more points (voltages and frequencies), which respectively are set equal.

The slope (ratio of V/F) after point (F5, V5) must be equal to the slope between point (F5, V5) and the previous point.

C017* Start Adjustments

C01.71	Function Description	Range	Unit	Default Setting
	Start Delay	0.0~10.0	S	0.0

Function: This parameter enables a delay of the starting time. The frequency converter begins with the start function selected in par. 1-72. Set the start delay time until acceleration is to begin.

Attention: Setting start delay to 0.0 sec. disables Start Function, [C0172], when start command is given.

C01.72	Function Description	Range	Unit	Default Setting
	Start Function	0~2		2

Option: [0] DC Hold;

[2] Coast;

Function: Select [0], Motor is energized with DC holding current (par. C0200)

during start delay time; Select [2], Motor is coasted during start delay time (inverter off).

*C01.73	Function Description	Range	Unit	Default Setting
	Flying Start	0~1		0

Option: [0] Disabled;

[1] Enabled;

Description of Choice: This function applies for the inertia load to restart due to mains drop-out; If Clockwise[0] is selected(C04.10), and no rotating motor is found, It is possible to use DC-brake command to ramp down the motor speed to 0 rpm, and then start the motor in the normal way; If Both directions [2](C04.10) is selected, and no rotating motor is found, the drive will assume the motor is stationary or in low-speed rotation, and then start the motor in the normal way. When Flying start is enabled, C01.71 (Start delay) and C01.72 (Start function) is invalid.

Warning: This function is not suitable for hoisting applications.

C01.8* Stop Adjustments

C01.80	Function Description	Range	Unit	Default Setting
	Function at Stop	0~1		0

Option: [0] Coast, the inverter is off;

[1] DC Hold, the motor is energized with a DC current. See par. C02.00 DC Hold Current for more information.

Function: Here it is possible to select the stop function according to different applications.

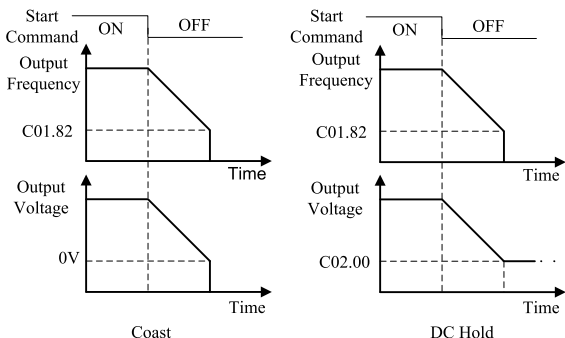

Description of Choice: This function is active in the following situations: Stop command is given and output speed is ramped down to Min. Speed for activating Functions at Stop; Start command is removed (standby), and output speed is ramped down to Min. Speed for activating Functions at Stop; DC-brake command is given, and lasts out of DC-brake delay time.

C01.82	Function Description	Range	Unit	Default Setting
	Min Speed for Function at Stop [Hz]	0.0~400.0	Hz	0.0

Function: Set the output frequency at which to activate par. C0180 Function at stop.

7.3 Parameter Group 02: Brakes

C02.0* DC -Brake

C02.00	Function Description	Range	Unit	Default Setting
	DC Hold Current	0~150	%	50

Function: This parameter either holds the motor (holding torque) or preheats the motor. This parameter is active if DC Hold has been selected in either C0172 start function or C0180 Function at Stop.

Description of Choice: Enter a value for holding current as a percentage of the rated motor current set in par. C0124 Motor Current. 100% DC holding current corresponds to $I_{M,N}$.

Attention: Avoid 100% current too long as it may overheat the motor.

C02.01	Function Description	Range	Unit	Default Setting
	DC Brake Current	0~150	%	50

Function: This parameter is used for setting the DC brake currents that is set as a percentage value of the rated motor current $I_{M,N}$ set in C0124.

Description of Choice: Parameters related to the DC brake current are as follows:

DC-brake command, see C051* choice (5);

DC brake cut in speed, see C02.04;

C02.02	Function Description	Range	Unit	Default Setting
	DC Braking Time	0.0~60.0	S	10.0

Function: This parameter defines DC brake current (C0201) time during which

DC-brake current is applied to the motor.

C02.04	Function Description	Range	Unit	Default Setting
	DC Brake Cut in Speed	0.0~400.0	Hz	0.0

Function: This parameter is for setting the DC brake cut in speed at which the DC braking current (par.02.0l) is to be activated, in connection with a stop command. When set to 0 the function is off.

C02.1* Brake Energy Funct.

C02.10	Function Description	Range	Unit	Default Setting
	Brake Function	0~2		0

Option: [0] off;

[1] Resistor brake, use the resistor brake to consume surplus energy resulting from motor braking, and prevent the frequency converter to trip due to over-voltage in the intermediate circuit;

Attention: Resistor brake is only functional when the frequency converter build-in braking unit or external braking unit must be installed.

C02.11	Function Description	Range	Unit	Default Setting
	Brake Resistor (ohm)	5~65535	Ω	*

Function: Set brake resistor value.

C02.17	Function Description	Range	Unit	Default Setting
	Over-voltage Control	0~2		0

Option: [0] Disabled, The OVC is not active/required;

[2] Enabled, OVC is running;

Function: OVC is used to consume surplus energy by increasing the output frequency. Select whether to enable OVC, which reduces the risk of drive trip due to over voltage on the DC link caused by generative power from load.

Attention: The OVC is not active/required if resistor brake has been chosen in C02.10 (Brake Function).

7.4 Parameter Group 03: Reference/Ramps

C03.0* Reference Limits

C03.03	Function Description	Range	Unit	Default Setting
	Maximum Reference	0.000~4999.000		50.000

Function: Enter value for Maximum Reference.

Description of Choice: The sum of all internal and external references is clamped (limited) to the maximum reference value.

C03.07	Function Description	Range	Unit	Default Setting
	Actual reference calculation	0~1		0

Option: [0] Preset reference + Reference source 1,2

[1] Preset reference priority

Description of Choice:

[0], Actual reference = Preset reference + Reference source 1,2

[1], When using preset reference 1-N, actual reference = preset reference [1-N], else actual reference = preset reference [0] + reference source 1,2

C03.1** References

C03.10	Function Description	Range	Unit	Default Setting
	Preset Reference	-100.00~100.00[8]	%	0.00

Function: This parameter is an array-8 to be used for presetting different references.

Description of Choice: 100%= value set in C03.03; It contains 8 preset references which are selectable via digital terminals or local bus. See C05.1*. Selection of preset reference indicates with a three-digital binary code. If the frequency converter detects the corresponding terminals connected, then the bit is "1", otherwise, the bit is "0". Digital input terminal, binary code and the corresponding relationship between preset values as follows:

Binary system	bit2	bit1	bit0	Preset Reference
Terminals State	0	0	0	0
	0	0	1	1
	0	1	0	2
	0	1	1	3
	1	0	0	4
	1	0	1	5
	1	1	0	6
	1	1	1	7

C03.11	Function Description	Range	Unit	Default Setting
	Jog Speed	0.0~400.0	Hz	5.0

Function: Jog frequency is a fixed frequency that the drive supplies to the motor after the jog function is activated. Please refer to C05.1*, select [14].
 Description of Choice: The frequency converter with the highest priority will operate at jog speed when a variety of run command activates. Removing the jog signal makes the frequency converter run according to the selected configuration, this parameter is set limited by C04.14.

C03.12	Function Description	Range	Unit	Default Setting
	Catch up/Slow down Value	0.00~100.00	%	0.00

Function: This parameter enables the entry of a percentage value (relative) which will to be either added to or deducted from the actual reference.
 Description of Choice: The Catch up/Slow down function is activated by a digital input terminal (See C05.1*, choose [28]/ [29]). If this function is active, the catch up/slow down value will be added to the actual reference constituting new setting at which the frequency converter is going to run, calculated as follows:

$$\text{Total reference} = \text{reference} \pm \text{reference} \times (\text{Catch up/Slowdown value})$$
 If this function is inactive, the reference returns to its original value (the actual reference).

For example: Set C05.12=28, C05.13=29, C03.12=30, assuming the actual reference value is 20 Hz, when only DI1 is on, the output frequency is 26 Hz, when only DI2 is connected, the output frequency is 14Hz, when both DI1 and DI2 are on, the output frequency is 20Hz.

C03.14	Function Description	Range	Unit	Default Setting
	Preset Relative Reference	-100.00~100.00	%	0.00

Function: Define an adjustable Preset Relative Reference which is to be added to the total reference as a percentage value of the actual reference .

Total Reference=Actual Reference+Actual Reference * Preset Relative Reference + Actual reference * Relative Scaling Reference

Example:

Min Reference/ C0302	Preset Relative Reference/ C0314	Relative Scaling Reference VI/C0318=1	Preset Reference/ C0310	Max Reference/ C0303	Output Frequency (Hz)
0	0%	10V	20%	50	10+0+10=20
0	10%	8V	20%	50	10+1+8=19
0	20%	5V	20%	50	10+2+5=17
0	30%	3V	20%	50	10+3+3=16
0	40%	0V	20%	50	10+4+0=14

C03.15	Function Description	Range	Unit	Default Setting
	Reference Resource1	0~21		1

C03.16	Function Description	Range	Unit	Default Setting
	Reference Resource2	0~21		2

Option: [0] No function, no reference resource is defined;

[I] Analog in VI, use signals from Analog input VI as reference resource, see C06.1*;

[II] Local bus reference, use signals from Local bus reference as reference resource, see C08.9;

[2I] LCP potentiometer, use signals from LCP potentiometer as reference resource, see C06.8*;

Function: C0315, C0316 define up to three different reference signals, the sum of which defines is the actual reference.

C03.18	Function Description	Range	Unit	Default Setting
	Relative Scaling Ref.	0~21		0

Option: [0] No function: No relative scaling ref. resource is defined;

[1] Analog input VI, select analog input VI as relative scaling ref. source, see C06.F*;

[1I] Local bus reference, select local bus reference as relative scaling ref. source, see par. C08.9*;

[2I] LCP potentiometer, select LCP potentiometer as relative scaling ref. source, see par. C06.8*;

Function: The Relative Scaling Ref. Resource can be set via Analog input terminals, Local bus reference and LCP potentiometer.

Total Reference=Actual Reference + Actual reference * Relative Scaling Reference.

Example:

Preset Reference/ C03.10	Relative Scaling Reference VI/ C03.18=1	Max Reference/ C03.03	Output Frequency(Hz)
20%	10V	50	10+10=20
20%	8V	50	10+8=18
20%	5V	50	10+5=15
20%	3V	50	10+3=13
20%	0V	50	10+0=10

C03.19	Function Description	Range	Unit	Default Setting
	Save Speed Up/Down Value	0~2		0

Option: [0] No Function;

[1] Stop Save;

[2] Power Down Save;

Function: This parameter is used for setting whether to save the data changed in the Up/Down function if the frequency stops or after it power down.

C03.4* Ramp1

C03.40	Function Description	Range	Unit	Default Setting
	Ramp 1 Type	0~2		0

Option: [0] Linear: Motor ramp up to the preset frequency with constant acceleration.

[2] S ramp: Motor ramp to the preset frequency with non-linear acceleration.

Description of Choice: If Linear [1] is selected, the frequency may exceed the preset setting during the acceleration; If S ramp [2] is selected, due to smoother S curve, it will automatically adjust acceleration when approaching to the preset frequency to avoid exceeding it.

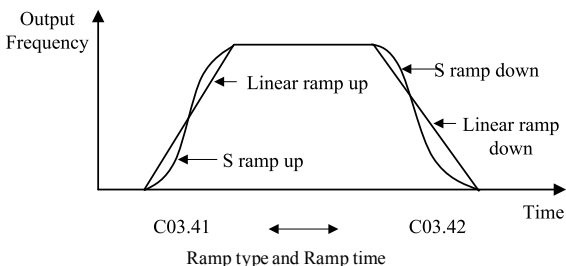

Attention: It is possible to switch acceleration and deceleration via digital input terminals, see parameter C05.P* choice. The state of the digital input terminal is shown in binary code; If the drive detects the corresponding digital input terminals connected, then the bit is '1', on the contrary is '0'. The corresponding relationship between state of the digital input terminals, binary code and the selected ramp type are as follows:

Binary system	bit2	bit1	bit0	Ramp Group
Terminal State	0	0	0	1
	0	0	1	2
	0	1	0	3
	0	1	1	4
	1	0	0	5
	1	0	1	6
	1	1	0	7
	1	1	1	8

C03.41	Function Description	Range	Unit	Default Setting
	Ramp1 Ramp up Time	0.10~300.00	S	*

Function: Enter the ramp-up time from 0 Hz to rated Motor speed in C01.25.

Attention: Choose a ramp-up time such that the output current does not exceed the current limit in C04.8.

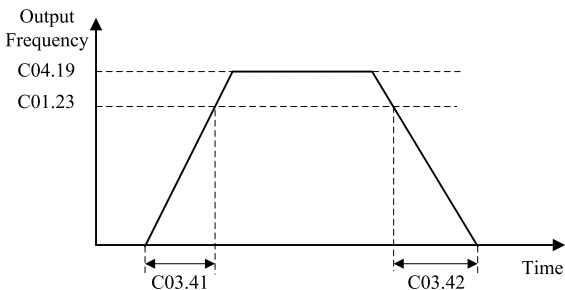

C03.42	Function Description	Range	Unit	Default Setting
	Ramp1 Ramp Down Time	0.10~300.00	S	*

Function: Enter the deceleration time from the rated motor speed in C01.25 to 0Hz.

Attention: Choose a ramp-down time such that no over-voltage arises in the inverter due to regenerative operation of motor and such that the generated current does not exceed the current limit set in C04.8.

C03.5* Ramp2

C03.50	Function Description	Range	Unit	Default Setting
	Ramp2 Type	0~2		0

Option: [0] Linear: Motor ramp up to the preset frequency with a constant acceleration;

[2] S-ramp: Motor ramp to the preset frequency with non-linear acceleration.

C03.51	Function Description	Range	Unit	Default Setting
	Ramp2 Ramp up Time	0.10~300.00	s	*

Function: Enter the ramp-up time from 0Hz to rated Motor speed in C0L25.

Attention: Choose a ramp-up time such that the output current does not exceed the current limit set in C04I8.

C03.52	Function Description	Range	Unit	Default Setting
	Ramp2 Ramp down Time	0.10~300.00	S	*

Function: Enter the deceleration time from the rated motor speed in C0L25 to 0Hz.

Attention: Choose a ramp-down time such that no over-voltage arises in the inverter due to regenerative operation of motor and such that the generated current does not exceed the current limit set in C04I8.

C03.6* Ramp3

C03.60	Function Description	Range	Unit	Default Setting
	Ramp3 Type	0~2		0

Option: [0] Linear: Motor ramp up to the preset frequency with a constant acceleration;

[2] S-ramp: Motor ramp to the preset frequency with non-linear acceleration.

C03.61	Function Description	Range	Unit	Default Setting
	Ramp3 Ramp up Time	0.10~300.00	S	*

Function: Enter the acceleration time from 0Hz to rated Motor speed in C0L25.

Attention: Choose a ramp-up time such that the output current does not exceed the current limit set in C04I8.

C03.62	Function Description	Range	Unit	Default Setting
	Ramp3 Ramp Down Time	0.10~300.00	S	*

Function: Enter the deceleration time from the rated motor speed in C0L25 to 0Hz.

Attention: Choose a ramp-down time such that no over-voltage arises in the inverter due to regenerative operation of motor and such that the generated current does not exceed the current limit set in C04I8.

C03.7* Ramp4

C03.70	Function Description	Range	Unit	Default Setting
	Ramp4 Type	0~2		0

Option: [0] Linear: Motor ramp up to the preset frequency with a constant acceleration;
 [2] S-ramp: Motor ramp to the preset frequency with non-linear acceleration.

C03.71	Function Description	Range	Unit	Default Setting
	Ramp4 Ramp up Time	0.10~300.00	S	*

Function: Enter acceleration time from 0Hz to rated Motor speed in C0L25.
 Attention: Choose a ramp-up time such that the output current does not exceed the current limit set in C04I8.

C03.72	Function Description	Range	Unit	Default Setting
	Ramp4 Ramp Down Time	0.10~300.00	S	*

Function: Enter the deceleration time from the rated motor speed in C0L25 to 0Hz.
 Attention: Choose a ramp-down time such that no over-voltage arises in the inverter due to regenerative operation of motor and such that the generated current does not exceed the current limit set in C04I8.

C03.8* Other Ramps

C03.80	Function Description	Range	Unit	Default Setting
	Jog Ramp Time	0.10~300.00	S	*

Function: Enter the time required motor speed from 0Hz up to rated motor speed (C0L25) or from the rated motor speed (C0L25) down to 0Hz.
 Description of Choice: Jog ramp time starts upon activation of a jog signal via a selected digital input or serial communication port. See C05I, choose [14].

C03.84	Function Description	Range	Unit	Default Setting
	Ramp5 Type	0~2		0

Option: [0] Linear: Motor ramp up to the preset frequency with a constant acceleration;
 [2] S-ramp: Motor ramp to the preset frequency with non-linear acceleration.

C03.85	Function Description	Range	Unit	Default Setting
	Ramp5 Ramp up Time	0.10~300.00	S	*

Function: Enter acceleration time from 0Hz to rated Motor speed in C0L25.

Attention: Choose a ramp-up time such that the output current does not exceed the current limit set in C04I8.

C03.86	Function Description	Range	Unit	Default Setting
	Ramp5 Ramp Down Time	0.10~300.00	S	*

Function: Enter the deceleration time from the rated motor speed in C0L25 to 0Hz.

Attention: Choose a ramp-down time such that no over-voltage arises in the inverter due to regenerative operation of motor and such that the generated current does not exceed the current limit set in C04I8.

selected digital input or serial communication port. See C05I, choose [I4]

C03.87	Function Description	Range	Unit	Default Setting
	Ramp6 Type	0~2		0

Option: [0] Linear: Motor ramp up to the preset frequency with a constant acceleration;

[2] S-ramp: Motor ramp to the preset frequency with non-linear acceleration.

C03.88	Function Description	Range	Unit	Default Setting
	Ramp6 Ramp up Time	0.10~300.00	S	*

Function: Enter acceleration time from 0Hz to rated Motor speed in C0L25.

Attention: Choose a ramp-up time such that the output current does not exceed the current limit set in C04I8.

C03.89	Function Description	Range	Unit	Default Setting
	Ramp6 Ramp Down Time	0.10~300.00	S	*

Function: Enter the deceleration time from the rated motor speed in C0L25 to 0Hz.

Attention: Choose a ramp-down time such that no over-voltage arises in the inverter due to regenerative operation of motor and such that the generated current does not exceed the current limit set in C04I8.

selected digital input or serial communication port. See C05I, choose [I4]

C03.90	Function Description	Range	Unit	Default Setting
	Ramp7 Type	0~2		0

Option: [0] Linear: Motor ramp up to the preset frequency with a constant acceleration;
 [2] S-ramp: Motor ramp to the preset frequency with non-linear acceleration.

C03.91	Function Description	Range	Unit	Default Setting
	Ramp7 Ramp up Time	0.10~300.00	S	*

Function: Enter acceleration time from 0Hz to rated Motor speed in C0L25.
 Attention: Choose a ramp-up time such that the output current does not exceed the current limit set in C04.I8.

C03.92	Function Description	Range	Unit	Default Setting
	Ramp7 Ramp Down Time	0.10~300.00	S	*

Function: Enter the deceleration time from the rated motor speed in C0L25 to 0Hz.
 Attention: Choose a ramp-down time such that no over-voltage arises in the inverter due to regenerative operation of motor and such that the generated current does not exceed the current limit set in C04.I8. selected digital input or serial communication port. See C05.I, choose [4].

C03.93	Function Description	Range	Unit	Default Setting
	Ramp8 Type	0~2		0

Option: [0] Linear: Motor ramp up to the preset frequency with a constant acceleration;
 [2] S-ramp: Motor ramp to the preset frequency with non-linear acceleration.

C03.94	Function Description	Range	Unit	Default Setting
	Ramp8 Ramp up Time	0.10~300.00	S	*

Function: Enter acceleration time from 0Hz to rated Motor speed in C0L25.
 Attention: Choose a ramp-up time such that the output current does not exceed the current limit set in C04.I8.

C03.95	Function Description	Range	Unit	Default Setting
	Ramp8 Ramp Down Time	0.10~300.00	S	*

Function: Enter the deceleration time from the rated motor speed in C0125 to 0Hz.

Attention: Choose a ramp-down time such that no over-voltage arises in the inverter due to regenerative operation of motor and such that the generated current does not exceed the current limit set in C0418.

C03.96	Function Description	Range	Unit	Default Setting
	Link preset reference and	0.10~300.00	S	*

Option: [0] No link;
[1] Link.

Function: If choose [1] link preset reference and ramp time, preset reference 0-7 are corresponding to ramp time 1-8. For example, choose preset reference 2 by using terminals control, the ramp time is 3.

7.5 Parameter Group 04: Limits/warnings

C04.1* Motor Limits

*C04.10	Function Description	Range	Unit	Default Setting
	Motor Speed Direction	0~2		2

Option: [0] Clockwise, the motor shaft rotates in clockwise direction; this setting prevents the motor from running in counter clockwise direction.

[1] Counter clockwise, motor shaft rotates in counter clockwise direction, this setting prevents the motor from running in clockwise direction.

[2] Both Directions, with this setting, the motor can run in both directions.

*C04.12	Function Description	Range	Unit	Default Setting
	Motor Speed Low Limit	0.0~400.0	Hz	0.0

Function: Set the minimum limit for Motor Speed, the motor speed low limit can be set to correspond to the minimum output frequency of the motor shaft. The motor speed low limit must not exceed the Motor Speed High Limit in C0414.

*C04.14	Function Description	Range	Unit	Default Setting
	Motor Speed High Limit	0.0~400.0	Hz	65.0

Function: Enter the maximum limit for Motor Speed , the motor speed high limit can be set to correspond to the maximum manufacture's rated motor speed. The motor speed high limit must exceed the Motor Speed Low Limit in C04.19.

C04.18	Function Description	Range	Unit	Default Setting
	Current Limit	0~300	%	150

Function: Set the output current high limit.

Attention: If a setting in C0L20 to C0L25 is changed, this parameter is not automatically reset to default setting.

*C04.19	Function Description	Range	Unit	Default Setting
	Max Output Frequency	0.0~400.0	Hz	65

Function: Enter value of the maximum output frequency.

C04.5* Adj. Warnings

C04.52	Function Description	Range	Unit	Default Setting
	Warning Speed Low	0.0~400.0	Hz	0.0

Function: Enter the n_{low} value, when the motor speed falls below this limit, the display reads Speed Low.

Attention: This setting must be within normal motor frequency range, otherwise, it may trigger an error warning.

C04.53	Function Description	Range	Unit	Default Setting
	Warning Speed High	0.1~400.0	Hz	65.0

Function: Enter the n_{high} value, when the motor speed exceeds this limit, the display reads Speed High.

Attention: This setting must be within normal motor frequency range, otherwise, it may trigger an error warning.

*C04.58	Function Description	Range	Unit	Default Setting
	Missing Motor Phase Function	0~1		1

Option: [0] Off, function is disabled;

[1] On, function is enabled;

Attention: Missing motor phase causes motor torque to decrease. This function may be disabled for special purpose (eg. small motor running pure U/f mode). However, choosing [0] Off, function disabled, may lead to overheating. Holip strongly recommends to make an active setting to avoid motor damage.

C04.6* Speed Bypass

C04.61	Function Description	Range	Unit	Default Setting
	Bypass Speed From	0.0~400.0	Hz	0.0

Array: [3]

Function: This parameter is a dyadic Array, [0] is used to set the bypass speed from of bypass speed range 1, [1] is used to set the bypass speed from of bypass speed range 2, and [2] is used to set that of bypass speed range 3.

Description of Choice: Some systems call for avoiding some certain output speed due to resonance problems in system. The drive will pass quickly when it approaching to the Bypass Speed area.

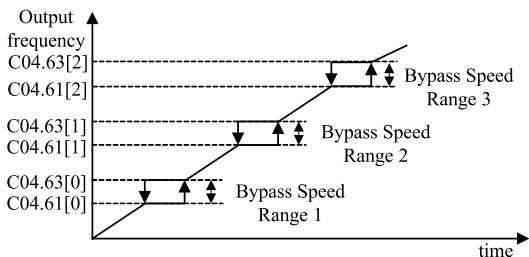

C04.63	Function Description	Range	Unit	Default Setting
	Bypass Speed to	0.0~400.0	Hz	0.0

Array: [3];

Function: This parameter is a dyadic array, [0] is used to set the bypass speed to of bypass speed range 1, [1] is used to set the bypass speed to of bypass speed range 2, and [2] is set as that of bypass speed range 3.

7.6 Parameter Group 05: Digital Input/Output

C05.1* Digital Input

C05.10	Function Description	Range	Unit	Default Setting
	Terminal FOR Digital Input	0~36		8
C05.11	Function Description	Range	Unit	Default Setting
	Terminal REV Digital Input	0~36		10
C05.12	Function Description	Range	Unit	Default Setting
	Terminal DI1Digital Input	0~36		15
C05.13	Function Description	Range	Unit	Default Setting
	Terminal DI2Digital Input	0~36		16
C05.14	Function Description	Range	Unit	Default Setting
	Terminal DI3Digital Input	0~36		17

Option: [0] No operation, the frequency converter will not to react to signals transmitted to the terminal;

[1] Reset, reset the frequency converter after a Trip/Alarm;

[2] Coast Inverse, no output, leaving the motor coasting to stop;

[5] DC-brake Inverse, see C02.01, this function is only active when value in C02.02 and C02.04 are different from 0.

[6] Stop Inverse, the drive is stopped according to selected ramp time;

[8] Start, 1=start, 0=stop;

[10] Reversing, change direction of motor shaft rotation, reversing signal only changes direction of rotation, it does not activate start function, C04.10 must choose [2] Both directions;

[11] Start reversing, used for start/stop and for reversing at the same time;

[14] Jog, used for activating jog speed, see C03.11;

[15] Preset ref. bit0, Preset ref.bit0, bit1, bit2, bit3 is used for the choice of the preset reference, see parC03.10;

[16] Preset ref. bit1, same as[15];

[17] Preset ref. bit2, same as [15];

[28] Catch up, select catch up to increase the resulting reference value by the percentage set in par. C03.12;

[29] Slow down, select slow down to reduce the resulting reference

value by the percentage set in par. C0312;

[34] Ramp bit0, bit0, bit1, bit2 used for select acceleration or deceleration;

[35] Ramp bit1, same as [34];

[36] Ramp bit2, same as [34];

C05.4* Relay

C05.40	Function Description	Range	Unit	Default Setting
	Relay Function	0~55		5

Option: [0]No operation;

[5]Drive running, Motor is running;

[9]Alarm. Frequency converter alarms;

[10]Alarm or warning. An alarm or warning occurs;

[15]Beyond frequency range. Output frequency beyond range set in C04.52 and C04.53;

[16]Below frequency, low. Output frequency is lower than value set in C04.52;

[17]Above frequency,high. Output frequency is higher than value set in C04.53;

[21]Thermal warning. A thermal warning occurs;

[24]Ready-Voltage OK. Frequency converter is ready for operation, main voltage is within specified voltage range;

[25]Reverse. Motor runs in counter clockwise;

[26]Bus OK. Local bus communication is normal;

[28]Brake-No warning. Brake is active, and no warnings are present;

[53]No alarm. Frequency converter is running normally, no alarm;

[55]Running reverse. Drive runs in counter clockwise;

7.7 Parameter Group 06: Analog In/Out

C06.1* Analogue Input 1

C06.10	Function Description	Range	Unit	Default Setting
	Terminal VI Low Voltage	0.00~9.99	V	0.07

Function: Enter VI Low Voltage corresponding to Min. reference/feedback set in C06.14.

C06.11	Function Description	Range	Unit	Default Setting
	Terminal VI High voltage	0.10~10.00	V	10.00

Function: Enter VI High Voltage corresponding to Max. reference/feedback set in C06.15.

C06.12	Function Description	Range	Unit	Default Setting
	Terminal VI Low Current	0.00~19.99	mA	mA

Function: Enter VI Low Current corresponding to Min. reference/feedback set in C06.14.

C06.13	Function Description	Range	Unit	Default Setting
	Terminal VI High Current	0.01~20.00	mA	20.00

Function: Enter VI High Current corresponding to Max. reference/feedback set in C06.15.

C06.14	Function Description	Range	Unit	Default Setting
	Terminal VI Low Ref./Feedb.	-4999.000~4999.000		0.000

Function: Enter VI Low Ref./Feedb. Corresponding to Min. voltage or min. current set in C06.10 or C06.12.

C06.15	Function Description	Range	Unit	Default Setting
	Terminal VI High Ref./Feedb.	-4999.000~4999.000		50.000

Function: Enter VI High Ref./Feedb. Corresponding to max voltage or max current set in C06.11 or C06.13.

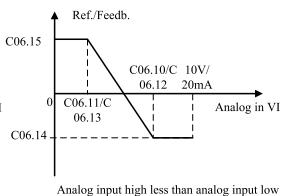
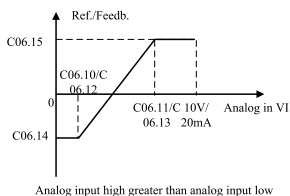

C06.16	Function Description	Range	Unit	Default Setting
	Terminal Filter Time Constant	0.01~10.00	s	0.01

Function: Enter the time constant, this is a first-order digital low pass filter time constant for suppressing electrical noise in analog input VI. A high time constant value improves dampening but also increases the time delay through the filter. This parameter can't be adjusted while the motor is running.

C06.18	Function Description	Range	Unit	Default Setting
	Terminal VI Zero Dead Band	0.00~20.00	V/mA	0.00

Function: Set the dead-band of VI at 0 speed. When analog input VI ref. low and ref. high have opposite signs, there must be a set point that corresponding to an analogue value equals 0. In order to prevent the set point jitter at zero point due to analog interference, this parameter should be set properly.

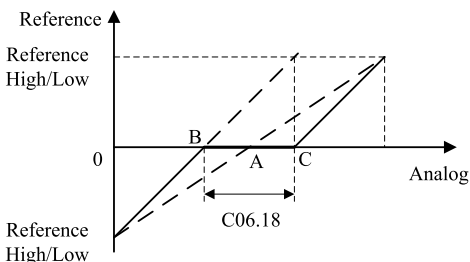

Description of Choice: Point A as shown in the figure is the analog value that corresponds to a setpoint that equals 0. It is calculated via analog low, high values and low, high references. $U_{AB}=U_{AC}=C06.18/2$

C06.19	Function Description	Range	Unit	Default Setting
	Terminal VI Mode	0~1		0

Option: [0] Voltage mode;

[1] Current mode;

Function: Select the input to be present on analog input VI.

C06.8* LCP Potmeter

The LCP potmeter can be select either as reference resource or relative reference resource.

C06.81	Function Description	Range	Unit	Default Setting
	LCP Potmeter Low Ref.	-4999.000~4999.000		0.000

Function: This reference value corresponding to potentiometer turned fully counterwise .

C06.82	Function Description	Range	Unit	Default Setting
	LCP Potmeter High Ref.	-4999.000~4999.000		50.000

Function: This reference value corresponding to potentiometer turned fully clockwise.

7.8 Parameter Group 07: Controller

C07.2* Process Ctrl. Feedb

C07.20	Function Description	Range	Unit	Default Setting
	Process CL Feedback 1	0~11		0

Option: [0] No Function;

[1] Analog in VI(0-10 V, 0-20 mA, 4-20 mA);

[H] Local Bus (0 ~ ± 200%);

Function: Select resource of feedback signal.

C07.3* Process PI Ctrl.

This parameter is active in closed loop process control mode.

C07.31	Function Description	Range	Unit	Default Setting
	Process PI Anti Windup	0~1		1

Option: [0] Disable, continue regulation of a given error even when the output frequency can't be increased/decreased.

[1] Enable, ceases regulation of a given error when the output frequency can't be increased/decreased.

Function: This function ensures the output frequency reaches to frequency limit. PI-controller will be initialized to the current frequency when the output frequency can not be changed. This can prevent the integrator continue to integrate on an error when the PI-controller can't adjust output frequency.

C07.33	Function Description	Range	Unit	Default Setting
	Process PI Proportional Gain	0.0~10.00		0.01

Function: The proportional Gain indicates the number of times the error between the set point and the feedback signal is to be applied. Quick control is obtained by a high gain, but if the gain is too high, the process may become unstable.

Attention: This function is disabled when it is set to “0”.

C07.34	Function Description	Range	Unit	Default Setting
	Process PI Integral Time	0.10~9999.00	s	9999.00

Function: The integral time is the time needed by the integrator to reach the same gain as the porportional gain. Quick control is obtained at a short integral time, however, this time may become too short, which can make the process unstable.

C07.38	Function Description	Range	Unit	Default Setting
	Process PI Feed Forward Factor	0~400	%	0

Function: Feed Forward Factor acts an antidampening role to the PI action, setting this parameter to optimize the PI controller.

C07.39	Function Description	Range	Unit	Default Setting
	On reference Band Width	0~200	%	5

Description of Choice: The PI control error occurs according to the deviation between the setpoint and the feedback , when the deviation is less than set value in this parameter, On reference Band Width function is active.

C07.41	Function Description	Range	Unit	Default Setting
	Process PI Output Low	-100-100	%	0

Function: Process PI controller output low limit, 100% corresponds to C04.I9.

C07.42	Function Description	Range	Unit	Default Setting
	Process PI Output High	-100-100	%	100

Function: Process PI controller output High limit, 100% corresponds to C04.I9.

7.9 Parameter Group 08: Comm. and Options

C08.0* Comm. General Settings

C08.01	Function Description	Range	Unit	Default Setting
	Control mode	0~2		0

Option: [0] Digital and control word , use both digital input and control word as control;

[1] Digital only, use digital input as control;

[2] Control word only, use control word only as control;

C08.02	Function Description	Range	Unit	Default Setting
	Control Word Source	0~1		1

Option: [0] None, control word is inactive;

[1] FC RS485 , select local bus as control word source.

C08.03	Function Description	Range	Unit	Default Setting
	Control Word Time Out Time	0.1~6500.0	s	1.0

Function: This function is disabled, when the reference is set to 0. If the reference is not set to 0, the control word timeout time is not exceeded, and the serial communication is still innormal, action set in C08.04 will be carried out.

C08.04	Function Description	Range	Unit	Default Setting
	Contol Word Time Out Time	0~5		0

Option: [0] Off, No function;

[1] Freeze output, Freeze output until communication resumes.

[2] Stop, Stop with auto restart when communication resumes;

[3] Jogging, Run motor at jog frequency until communication resumes;

[4] Max. speed, Run motor at max.frequency until communication resumes;

[5] Stop and trip, Stop motor and restart frequency in order to restart via either LCP or Digital input .

Function: Select action to be taken in case of timeout.

C08.06	Function Description	Range	Unit	Default Setting
	Reset Control Word Time Out	0~1		0

Option: [0] No function Control word timeout is not reset;

[1] Do reset Control word timeout is reset;

Function: Resetting control word timeout will remove any timeout function;

C08.3* FC Port Setting

C08.31	Function Description	Range	Unit	Default Setting
	Address	0~247		1

Function: Select the address for the bus.

C08.32	Function Description	Range	Unit	Default Setting
	Port Baud Rate	0~9	bit/s	2

Option: [0] 2400;

[1] 4800;

[2] 9600;

[3] 19200;

[4] 38400;

Function: Select baud rate for Port.

C08.33	Function Description	Range	Unit	Default Setting
	Port Parity	0~3		2

Option: [0] Even parity (1 stop bit);

[1] Odd parity (1 stop bit);

[2] No parity (1 stop bit);

[3] No parity (2 stop bit);

C08.35	Function Description	Range	Unit	Default Setting
	Min. Response Delay	0.001~0.50	s	0.010

Function: Define the minimum delay time from receiving a request to transmitting the response out.

C08.36	Function Description	Range	Unit	Default Setting
	Max. Response Delay	0.010~10.000	s	5.000

Function: Specify maximum permissible delay time between transmitting a request and receiving a respond. Exceeding this time delay will cause word timeout.

C08.9* Bus Jog/Feedback

C08.94	Function Description	Range	Unit	Default Setting
	Bus Feedback 1	-32768~32767		0

Function: Enter the value to be used as bus-feedback. Hex-value 4000H corresponds to 100% feedback/range is +/-200%.

7.10 Parameter Group 14: Special Functions

C14.01	Function Description	Range	Unit	Default Setting
	Switching Frequency	0~10		5

Option: [2] - [6] 2-6kHz;
 [7] 8kHz;
 [8] 10kHz;
 [9] 12kHz;
 [10] 16kHz;

Description of choice: Switching frequency of the frequency converter has a significant influence to the inverter and the motor. Select appropriate switch frequency can help to adjust acoustic noise from the motor, power consumption and the inverter efficiency. When switching frequency increases, the consumption and the noise of the motor are reduced, but the drive's temperature will increase, and motor leakage and the interference to the external device will increase; the contrary the opposite.

*C14.03	Function Description	Range	Unit	Default Setting
	Over modulation	0~1		1

Option: [0] Off, Disable the overmodulation function to avoid torque ripple on the motor shaft;
 [1] On, Connects the overmodulation function to obtain an output voltage up to 15% greater than mains voltage;

Function: This feature allows more accurate speed control near and over

normal speed (50/60HZ). Another advantage with overmodulation is the ability of staying at a constant speed even though mains fault occurs.

C14.08	Function Description	Range	Unit	Default Setting
	Damping Gain Factor	0~200	%	96

Function: Damping gain factor can help to improve the response speed of the DC link of the frequency converter making the DC loop signal more smooth.

C14.1* Mains On/Off

C14.12	Function Description	Range	Unit	Default Setting
	Function at Mains Imbalance	0~2		0

Option: [0] Trip, frequency converter trips;
 [1] Warning, frequency converter issues a warning (but continues to run);
 [2] Disabled, no action is taken;

Function: Select actions when a severe mains imbalance is detected.

C14.2* Trip Reset

C14.20	Function Description	Range	Unit	Default Setting
	Reset Mode	0~13		0

Option: [0] Manual reset, perform reset via [reset]-button or digital inputs;
 [1] - [10] Auto reset 1-10, can perform 1-10 automatic resets after trips;
 [11] Auto reset11, can perform 15 automatic resets after trips;
 [12] Auto reset12, can perform 20 automatic resets after trips;
 [13] Infinite auto reset, can perform an infinite number of automatic resets after tripping;

Function: Select reset function after tripping. Once auto reset is selected, the frequency converter will be restarted after an alarm. If reset have been done and the running signal is active, frequency converter will restart automatically.

Attention: If the auto reset mode is selected, the frequency converter may possibly restart automatically after the alarm disappear.

C14.21	Function Description	Range	Unit	Default Setting
	Automatic Restart Time	0~600	s	10

Function: Enter time interval from trip to start of automatic reset function after a warning/alarm.

Description of Choice: This parameter is active when C14.20, Auto Reset, is set to Automatic reset [1][3].

C14.22	Function Description	Range	Unit	Default Setting
	Operation Mode	0~4		0

Option: [0] Normal operation;

[2] Initialization, initialise all the parameters except information about the inverter itself and the recorded parameters.

[3] Backup user settings;

[4] Recover user settings;

Function: After modifying the inverter parameters based on the functional requirements, OEM manufacturers can set C14.22 = 3 to backup settings. If the end user modify parameters and can not be self-recovery, it can be recovered by setting C14.22 = 4 or pressing "OFF" key on LCP 5 seconds.

C14.23	Function Description	Range	Unit	Default Setting
	Trip lock	0~1		0

Option: [0] Disable, Trip lock fault reset do not need power off

[1] Enable, Trip lock fault reset need power off

C14.5* DC Voltage Compensation

*C14.51	Function Description	Range	Unit	Default Setting
	DC-LinkVoltage Compensation	0~1		0

Option: [0] Disable;

[1] Enable;

Function: This function ensures the output voltage is independent of any voltage fluctuations in the DC link. Low torque ripple. In some cases, this dynamic compensation may cause resonance problems in DC link circuit and then this function should be disabled.

7.11 Parameter Group 15: Drive Information

C15.0* Operating Data

C15.00	Function Description	Range	Unit	Default Setting
	Operating Days	0~9999	d	

Function: View how many days the drive has run. The value is saved automatically at power off and can't be reset.

C15.02	Function Description	Range	Unit	Default Setting
	KWh Counter(kW)	0~65535	KW	

Function: View the power consumption from mains in Kwh as a mean value over one hour. Reset the counter in C1506.

C15.03	Function Description	Range	Unit	Default Setting
	Power Up's	0~2147483647	KW	

Function: View the number of times the drive has been powered up. This parameter can't be reset.

C15.06	Function Description	Range	Unit	Default Setting
	Reset Kwh Counter	0~1		

Option: [0] Do not reset;

[1] Reset counter, Counter is reset;

Attention: This parameter can't be set via local bus.

C15.3* Fault Log

C15.30	Function Description	Range	Unit	Default Setting
	Fault Log:Error Code	0~255		

Function: View the error code, and look up its meaning in chapter 10. This parameter group contains a fault log showing reasons for the ten latest trips.

C15.31	Function Description	Range	Unit	Default Setting
	Internal Fault Reason	-32767~32767		

Function: This parameter contains internal fault reasons, mostly used in combination with alarm 38.

C15.4* C15.5* Drive Identification

This parameter contains read only information about the hardware and software configuration of the frequency converter.

C15.40	Function Description	Range	Unit	Default Setting
	FC Type			

Description of Choice: View FC Type.

C15.41	Function Description	Range	Unit	Default Setting
	Power Section			

Description of Choice: View the power size of the frequency converter.

C15.42	Function Description	Range	Unit	Default Setting
	Voltage			

Description of Choice: View the voltage level corresponding to different type of drives.

C15.43	Function Description	Range	Unit	Default Setting
	Software version			

Description of Choice: View the software version of the drive.

C15.44	Function Description	Range	Unit	Default Setting
	Ordered Type Code			

Description of Choice: View the ordered type code of the drive.

C15.46	Function Description	Range	Unit	Default Setting
	FC ordering No.			

Description of Choice: View ordering number of the FC.

C15.47	Function Description	Range	Unit	Default Setting
	Power Card Ordering No.			

Description of Choice: View ordering number of the power card.

C15.49	Function Description	Range	Unit	Default Setting
	Software ID Control Card			

Description of Choice: View the control card ID number.

C15.50	Function Description	Range	Unit	Default Setting
	Software ID Power Card			

Description of Choice: View the power card ID number.

C15.51	Function Description	Range	Unit	Default Setting
	FC Serial Number			

Description of Choice: View the drives serial number.

C15.53	Function Description	Range	Unit	Default Setting
	Power Card Serial Number			

Description of Choice: View power card serial number.

C15.5* Defined parameters

C15.92	Function Description	Range	Unit	Default Setting
	Parameter List	0~255		

Function: View drive parameters that has been defined.

7.12 Parameter Group 16: Data Readouts

This parameter group is read-only.

C16.0* General Status

C16.01	Function Description	Range	Unit	Default Setting
	Reference	-4999.000~4999.000		

Function: View the total remote reference, the total reference is sum of pulse, analog, preset, LCP Potmeter, local bus and freeze reference.

C16.05	Function Description	Range	Unit	Default Setting
	Motor Speed [RPM]	0~9999	Hz	

Function: View motor speed.

C16.1* Motor Status

C16.10	Function Description	Range	Unit	Default Setting
	Power(kW)	0.000~1000.000	kW	

Function: View output power in KW.

C16.12	Function Description	Range	Unit	Default Setting
	Motor Voltage	0~65535	V	

Function: View motor phase voltage.

C16.13	Function Description	Range	Unit	Default Setting
	Frequency	0.0~400.0	Hz	

Function: View output frequency.

C16.14	Function Description	Range	Unit	Default Setting
	Motor Current	0.00~655.35	A	

Function: View motor phase current.

C16.3* Drive Status

C16.30	Function Description	Range	Unit	Default Setting
	DC Link Voltage	0~65535	V	

Function: View DC-link voltage.

C16.34	Function Description	Range	Unit	Default Setting
	Inverter Temp.	0~255		

Function: View the temperature of drive's heatsink.

C16.5* Ref./Feedb.

C16.52	Function Description	Range	Unit	Default Setting
	Feedback	-4999.000~4999.000		

Function: View analog or pulse feedback in HZ.

C16.6* C16.7* Inputs and Outputs

C16.60	Function Description	Range	Unit	Default Setting
	Digital Input	0~65535		

Function: View signal states from active digital inputs, which indicates in a 16-bit binary code. If the drive detects digital input terminals connected, the corresponding position is set to “1”, otherwise “0”. Digital input terminal and the corresponding relationship between the binary code are as below:

Binary	Term. No.	Binary	Term. No.	Binary	Term. No.	Binary	Term. No.
bit0	FOR	bit4	DI3	bit8	Reserved	bit12	Reserved
bit1	REV	bit5	Reserved	bit9	Reserved	bit13	Reserved
bit2	DI1	bit6	Reserved	bit10	Reserved	bit14	Reserved
bit3	DI2	bit7	Reserved	bit11	Reserved	bit15	Reserved

C16.62	Function Description	Range	Unit	Default Setting
	Analog Input VI	0.00~20.00	V/mA	

Function: View actual input voltage or current value on analog input VI.

C16.71	Function Description	Range	Unit	Default Setting
	Relay Output	0~65535		

Function: View the output status of the relay, the corresponding bit is set to “1” when the relay output is active, otherwise it will be set to “0”.

Binary	bit0
Item. No.	Relay 1

C16.8* Field bus/FC Port

C16.86	Function Description	Range	Unit	Default Setting
	FC Port Reference	-32768~32767		

Function: View the last received reference from the FC port.

C16.9* Diagnosis Readouts

C16.90	Function Description	Range	Unit	Default Setting
	Alarm Word	0~0xFFFFFFFFFUL		

Function: View the alarm word sent via the serial communication port in hex

code. Convert this parameter to a 32-bit binary code, definition of the bits in alarm word showed in the table below, among which that reserved by manufacturers are undefined bits

Binary	Alarm Word/ C1690	Alarm Word 2 / C1691	Warning Word/ C1692	Warning Word 2/C1693
0	Brake detect	Undefined	Undefined	Undefined
1	Power Card over Temp.	Undefined	Power Card over Temp.	Undefined
2	Earth Fault	Trip	Earth Fault	Undefined
3	Undefined	Option part	Undefined	Undefined
4	Control Card Temp	Undefined	Control Card Temp	Undefined
5	Over Current	Undefined	Over Current	Undefined
6	Torque Limit	Undefined	Undefined	Undefined
7	Undefined	Undefined	Undefined	Undefined
8	Undefined	Damaged part	Undefined	Damaged part
9	Inverter Overload	Undefined	Inverter Overload	Undefined
10	DC Under Volt	Undefined	DC Under Volt	Undefined
11	DC Over Volt	Undefined	DC Over Volt	Undefined
12	Short Circuit	External Interlock	Undefined	Undefined
13	Undefined	Undefined	Undefined	Undefined
14	Mains ph. loss	Undefined	Mains ph. loss	Undefined
15	Undefined	Undefined	No motor	Undefined
16	Live zero error	Undefined	Live zero error	Undefined
17	Internal Fault	Undefined	Undefined	Undefined
18	Brake overload	Fan Fault	Brake overload	Fan Fault
19	U phase loss	Undefined	Undefined	Undefined
20	V phase loss	Undefined	Undefined	Undefined
21	W phase loss	Undefined	Undefined	Undefined
22	Undefined	Undefined	Undefined	Undefined

Binary	Alarm Word/ C16.90	Alarm Word 2 / C16.91	Warning Word/ C16.92	Warning Word 2/C16.93
23	Control Voltage Fault	Undefined	Undefined	Undefined
24	Undefined	Undefined	Undefined	Undefined
25	Undefined	Undefined	Current Limit	Undefined
26	Brake resistor error	Undefined	Undefined	Undefined
27	Brake transistor fault	Undefined	Undefined	Undefined
28	Bake transistor open circuit	Undefined	Undefined	Undefined
29	Drive initialize	Feedback error	Undefined	Feedback error
30	Undefined	Undefined	Undefined	Undefined
31	Mech. Brake low	Undefined	Undefined	Undefined

C16.91	Function Description	Range	Unit	Default Setting
	Alarm Word 2	0~0xFFFFFFFFUF		

Function: View the Alarm Word sent via serial communication port in hex code.

C16.92	Function Description	Range	Unit	Default Setting
	Warning Word 1	0~0xFFFFFFFFUF		

Function: View the Warning Word 1 sent via serial communication port in hex code.

C16.93	Function Description	Range	Unit	Default Setting
	Warning Word 2	0~0xFFFFFFFFUF		

Function: View Warning Word 2 sent via serial communication port in hex code.

Chapter 8 Accessory Specification

8.1 Braking Resistor

When the motor acts as a generator, the braking resistor consumes surplus energy resulting from motor braking to achieve fast stop. And to prevent the intermediate circuit voltage is too high to trip eventually.

Note: The braking resistor will be very hot, and will have a risk of fire, if the transistor in the braking unit is damaged and shorted. The installation length of the braking resistor should be not less than 5 meters.

Brake resistor (option):

Model	Braking Resistor Specification		Suitable Motor(KW)
	Ω	KW	
HLP-CI000D372I	310	0.25	0.37
HLP- CI000D752I	145	0.065	0.75
HLP- CI000ID52I	65	0.25	1.5
HLP- CI000D3723	310	0.25	0.37
HLP- CI000D7523	145	0.065	0.75
HLP- CI000ID523	65	0.25	1.5
HLP- CI000D7543	620	0.065	0.75
HLP- CI000ID543	310	0.25	1.5
HLP- CI0002D243	210	0.285	2.2

Note: An external braking unit is needed when connecting braking resistor for the FC which power is less than 220V/380V 0.75kW(included).



8.2 LCP Mounting Kit

8.2.1 External LCP Communication Cable

External LCP Communication Cable is network cable. Length should not exceed 15m. More than five types of shielded cable is recommended for use in the presence of electromagnetic interference environment.

8.2.2 Mounting steps

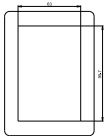
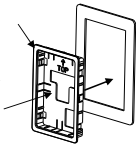
An external LCP mounting kit is provided; users need to open a hole (size as shown below). The installation steps are as follows:

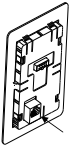
 <p>Step1 Open a hole in line with the size of the control panel in the position need to install the LCP, hole size, as shown:</p>	<p>This cradle is suitable for 1.0-2.0mm thickness sheet metal parts</p> <p>Press and hold the snap roots when installation, using buckle deformation install sheet metal.</p>  <p>Step2: Install the LCP according to the direction of the arrow.</p>
<p>Recommended to install vertical mounting position arrow, press with uniform force.</p>  <p>Step 3 The LCP is installed in the cradle, according to the direction of the arrow.</p>	 <p>Step 4 Install the external LCP communication cable, insert into RJ45 terminal from the bottom of hole.</p>

Chapter 9 EMC

9.1 EMC–Correct Installation

HLP-B serials drive implement the latest international standards, following these guidelines is advised, IEC/EN61800-3:2004 (Adjustable speed electrical power drive systems part 3: EMC requirements and specific test methods). In order to achieve the using requirements of the EMC, must meet the following specifications:

- Using shield motor cables, and connect it to the decoupling device (optional) and the metal motor cabinet;
- To reduce the noise and the leakage current, use the motor cable as short as possible;
- The entire system need to have a good earthing;
- RFI Switch screw must be tightened up.

9.2 RFI Switch

Use the RFI switch screw to remove the internal EMC filter, if the frequency converter is supplied from IT or TN Grid. If a drive with EMC filter is connected to the IT grid, then the system may be grounded through the EMC filter capacitors, this may cause damage to the inverter. If a drive with EMC filter is connected to the TN grid, the drive may be burned. Remove the RFI switch can help to reduce the leakage currents.

Chapter 10 Warnings/Alarms and Fault Handling

10.1 Fault List

The HLP-C100 drive has three different fault types: Warning, alarm and error. When a fault happens, the drive shows a specific code to indicate it.

When a warning happens, it means that the drive is close to its design limits for some reason, but the drive still works. If the drive fault disappear, the warning will also disappear.

An alarm means that the drive has exceeded its design limits for some reason. When this happens, the drive will trip. After an alarm the driver must be reset in order to re-run. When some alarms happen, the drive will lock itself. These alarms are called trip-lock alarm. The Trip-lock alarm offers additional protection, the default setting is that the main power should be cut off before resetting the alarm. But by setting parameters C14.23 = 0, the trip-lock alarm can be reset without cutting the main power off. But there is a risk of accident when choosing this function. Before using this function, it is important to be familiar with the drive and the whole system in order to be safe when dealing with the drive.

Error means that the drive is in a certain state where it is unable to carry out an operation.

Warning	Alarm	Error	Fault Description	Reason analysis
A.03	E.03		Motor Loss	Motor cable connection problems
A.04	E.04*		Mains Phase Loss	Missing phase on supply side or too high voltage imbalance. The allowed power imbalance of HLP-C100 series inverter is 3% of the rated voltage(IEC Standard)
A.07	E.07		Over Voltage	Intermediate circuit voltage exceeds limit.
A.08	E.08		Under Voltage	Intermediate circuit voltage drops below "voltage warning low" limit.
A.09	E.09		Inverter Overload	More than 100% overload for too long time.
A.10	E.10		Motor ETR Over Temperature	Motor temperature calculated by ETR exceeds upper limit
A.13	E.13*		Over Current	Inverter peak current limit is exceeded.

Warning	Alarm	Error	Fault Description	Reason analysis
A.14	E.14*		Earth fault	Discharge from output phases to ground(22KW and below)
	E.16*		Short Circuit	Short circuit in motor or on motor terminals.
A.17	E.17		Control Word Timeout	Drive communication timeout, this alarm occurs when C08.04 is set to 0 or 5.
A.24	E.24		Fan Fault	Too much dust on the fan or the fan is aging
	E.25*		Brake resistor short-circuit	Brake resistor is short circuit, leading the brake function invalid.
	E.27		Brake transistor short-circuit	Brake transistor is short circuit leading brake function invalid.
	E.28		Brake Detect	Brake resistor is not connected or working.
	E.30*		Motor phase U missing	Motor phase U is missing, check the phase.
	E.31*		Motor phase V missing	Motor phase V is missing, check the phase.
	E.32*		Motor phase W missing	Motor phase W is missing,check the phase.
	E.38*		Internal Fault	Contact the local distributor or Holip Company.
A.59			Current Limit	Current exceeds value set in C04.8.
A.61	E.61		Feedback Error	Feedback signal is out of range.
A.66			Heat sink low temperature	Temperature may be damaged.
A.69	E.69*		Power Card Temp.	Power card is over temperature.
A.79	E.79		Undefined fault	Contact local distributor or Holip Company.
	E.80		Parameter Initialization	Make parameter initialized.
		Er.84	LCP Connection with the inverter failed	No communication between LCP and the inverter.
		Er.85	Button is disabled	Refer to parameter group C04*

Warning	Alarm	Error	Fault Description	Reason analysis
		Er.89	Parameter read-only	Try to write read-only parameter.
		Er.90	Parameter Database Busy	LCP and RS485 connection try to update parameter at the same time.
		Er.91	Parameter value is invalid in this mode	Invalid parameter value to write.
		Er.92	Parameter Value Beyond Max./Min. Limit	Value try to be set exceeds the limit allowed.
		Err	Unchangeable	Parameter has frozen or can't be changed during running.

Note: Trip-lock alarm is with *.

10.2 Fault Indication and Trouble Shooting

The inverter of HLP-C100 series is relatively perfective with protection functions of overload, inter-phase short circuit, earth short circuit, and over-current etc. When a protection function occurs, please check reasons of the faults according to the information listed in the table below. The inverter can be restart after the disposal. If the fault can't be disposed, please contact the distributor or Holip company.

Fault	Process Method
1. Motor runs unsteadily	Motor runs unsteadily but no warnings issued, may be motor parameter settings are not correct, please adjust motor parameter settings, if no effect, please contact Holip Company.
2. Motor can't rotate	Confirm whether the screen display is normal; If screen display is properly, verify if warning or alarm information displays; If any warning or alarm occurred, please refer to corresponding troubleshooting section; If no warning or alarm occurred, please refer to item 5 below; If there is no screen display, please make sure if the supply voltage is correct; If the supply voltage is correct, please refer to item 4 below.
3. Motor brake function can't be performed.	Please refer to braking function section;

Fault	Process Method
4. No fault message or screen display	Confirm whether the input fuse meltdown; Verify whether control card is overload; Suppose control card is overload, and 24V is shorted, please remove the connection of control terminal; Make sure if any fault message is displayed, and if no, please contact Holip Company;
5. Motor can't rotate and screen display is normal without fault message	Press [Enter] on LCP; Make sure whether the screen is active i.e. the screen display can't be switched or parameter can't be edited; Suppose screen is freeze, please make sure screened cable used and connected correctly; If operation of the display screen is normal, please make sure connection between motor and the frequency converter is correct and then operate the drive in hand mode. Please contact Holip Company if motor can't rotate.

Chapter 11 Maintenance

11.1 Note

Confirm the main circuit power supply has been turned off, and the display has disappeared before carry out inspection and maintenance. Make sure the system is in dynamic state, please pay attention to the following:

- Check whether the power supply voltage matches to the rated voltage of the inverter;
- Check whether the motor makes unexpected noises or abnormal vibration when running;
- Check whether there are abnormal heating;
- Check whether the inverter output voltage, output current, output frequency, and monitor display is greater than the value commonly used.
- Check whether the cooling fan installed at the lower part of the inverter runs normally;
- Check whether the ambient temperature is too high and whether there is dust, iron filings, corrosive fluid in the inverter;
- Check whether the ambient temperature of the inverter is between $-10 \sim 40$, and whether the humidity is between 5%-85% (95% is without condensation), phenomenon of water droplets is not allowed;
- The inverter should be discarded as industrial waste. It is forbidden to burn it;

11.2 Storage and Transport

The inverter must be kept in its original package box before installation. Pay attention to the followings when keeping it in storage if the inverter is not used for the time being:

- It must be stored in a dry place without rubbish or dust;
- The suitable temperature for storage is between $-25 \sim -65$;
- The relative humidity required is 5%-95% without condensation;
- There is no corrosive gas or liquid in the storage ambience;
- It is better to lay the inverter on a rack and keep it in a proper package;
- The ambient temperature for transport is between $-25 \sim -70$;
- The relative humidity of transport ambience must be less than 95% (Ambient temperature is 40).

Attention: It is better not to store the inverter for long time. Long time storage of the inverter will lead to the deterioration of electrolytic capacity. If it needs to be stored for a long time make sure to power it up one time within a year and the power-up time should be at least above five hours. When powering up, supply voltage must be increased slowly with a voltage regulator to the rated voltage value.

Chapter 12 Communication protocol

HLP-C100 series inverter follows the standard Modbus RTU protocol.

12.1 Format specification

Address	Function code	Data	CRC
8 bits	8 bits	N*8 bits	16 bits

- 1) Address: 1-247
- 2) Function: HLP-C100 support following function code
 - 01: Read Coil Status
 - 03: Read Holding Registers
 - 05: Force Single Coil
 - 06: Preset Single Register
 - 15: Force Multiple Coils
 - 16: Preset Multiple Regs
- 3) DATA: N*8bits
- 4) CRC: CRC check

12.2 Coil addressing

Coil address	R/W	Description
0-15	R, W	Frequency converter control word (see following table)
16-31	R, W	Frequency converter speed or setpoint
32-47	R	Frequency converter status word(see following table)
48-63	R	Frequency converter output frequency
64	W	Parameter write control 0000-Parameter changes are written to the RAM; FF00- Parameter changes are written to the RAM and EEPROM;
65-65535		Reserved

FC control word

Coil address	0	1
00	Preset reference bit0	
01	Preset reference bit1	
02	DC brake	No DC brake
03	Coast stop	No coast stop
04	Reserved	
05	Freeze freq	No freeze freq
06	Ramp stop	Start
07	No reset	Reset
08	No jog	Jog
09	Ramp 1	Ramp 2
10	Data invalid	Data valid
11	Relay off	Relay on
12	Reserved	
13	Reserved	
14	Reserved	
15	No reversing	Reversing

Status word

Coil address	0	1
32	Control not ready	Control ready
33	Frequency converter not ready	Frequency converter ready
34	Coasting stop	Safety closed
35	No alarm	Alarm
36	Reserved	
37	Reserved	
38	Reserved	
39	No warning	Warning
40	Not at reference	At reference
41	Hand mode	Auto mode
42	Out of freq range	In freq range
43	Stopped	Running
44	Reserved	
45	No voltage warning	Voltage warning

Coil address	0	1
46	Not in current limit	Current limit
47	No thermal warning	Thermal warning

Register	Description
00000-00007	Reserved
00008	Parameter index
00009-00989	Parameter group 00
00999-01989	Parameter group 01
01999-02989	Parameter group 02
...	...
15999-16989	Parameter group 16

The relationship between register address and parameter number is:
 register address = parameter number × 10-1

12.3 Read Coil Status

Example: Detect inverter output frequency

Transmit: 01 01 00 30 00 10 3D C9 (Hexadecimal)

Receive: 01 01 02 00 20 B8 24 (Hexadecimal)

Transmit data

Field	Description
01	FC address
01	Function
00 30	Coil address (ADDRH ADDRL). 0x0030 convert to decimal number is 48. Coil address 49 is frequency converter output frequency.
00 10	Data bits number is 16. 0x 0010 convert to decimal number is 16
3D C9	CRC check

Receive data

Field	Description
01	FC address
01	Function
02	The read byte number is 2

Field	Description
00 20	Output frequency. Swap high and low, the data is 0x2000, so the output frequency is 50% of C0303. Why does 0x2000 correspond to 50%, please see 12.6.
B8 24	CRC check

12.4 Read Holding Registers

Example: Read the value of C0303

Transmit: 01 03 0B D5 00 02 D7 D7 (Hexadecimal)

Receive: 01 03 04 00 00 EA 60 B5 7B (Hexadecimal)

Transmit data

Field	Description
01	FC address
03	Function
0B D5	Register address(ADDRH ADDRL). The register address of C0303 is $303 \times 10 - 1 = 3029$ (0x0BD5)
00 02	The number of read registers is 2
D7 D7	CRC check

Receive data

Field	Description
01	FC address
03	Function
04	The byte number of received data
00 00 EA 60	0x0000EA60 convert to decimal number is 60000. So the value of C0303 is $60000 \times 0.001 = 60.000$
B5 7B	CRC check

12.4 Force Single Coil

Example: write parameter to RAM and EEPROM

Transmit: 01 05 00 40 FF 00 8D EE (Hexadecimal)

Receive: 01 05 00 40 FF 00 8D EE (Hexadecimal)

Transmit data

Field	Description
01	FC address
05	Function
00 40	0x0040 convert to decimal number is 64. The register address 64 is parameter write control
FF 00	0000-Parameter changes are written to the RAM; FF00- Parameter changes are written to the RAM and EEPROM;
8D EE	CRC check

Transmit data

Field	Description
01	FC address
05	Function
00 40	0x0040 convert to decimal number is 64. The register address 64 is parameter write control
FF 00	0000-Parameter changes are written to the RAM; FF00- Parameter changes are written to the RAM and EEPROM;
8D EE	CRC check

12.5 Preset Single Register

Example: set COL01 = 1

Transmit: 01 06 03 F1 00 01 19 BD (Hexadecimal)

Receive: 01 06 03 F1 00 01 19 BD (Hexadecimal)

Transmit data

Field	Description
01	FC address
06	Function
03 F1	The register address of COL01 is $10 \times 10 - 1 = 1009$ (0x03F1)
00 01	The parameter value is 1
19 BD	CRC check

Receive data

Field	Description
01	FC address
06	Function
03 F1	The register address of C0101 is 10*10-1=1009 (0x03F1)
00 01	The parameter value is 1
19 BD	CRC check

12.6 Force Multiple Coils

Example: the frequency is 40% of C0303.

Transmit: 01 0F 00 00 00 20 04 7C 04 9A 19 37 B3 (Hexadecimal)

Receive: 01 0F 00 00 00 20 54 13 (Hexadecimal)

Transmit data

Field	Description
01	FC address
0F	Function
00 00	Register address 0 is frequency converter control word.
00 20	The bit number is 32.
04	The byte number is 4
7C 04	Control word. "7C 04" swap high byte and low byte, the value is 0x047C Note: 0x047C convertes to binary is 0000 0100 0111 1100 are corresponding to the coil address 0-15
9A 19	Frequency reference: "9A 19" swap high byte and low byte, the value is 0x199A. Frequency is 40% of C0303 (see the following frequency conversion specification).
37 B3	CRC check

Frequency conversion specification:

If you want to set the frequency as 20Hz, 20Hz is 40% of the maximum frequency (it determined by the C0303 parameters, the default is 50Hz). Calculation method: $20/50 * 16384 = 65536$ converted to hexadecimal 0x199A.

So if you want to set the frequency as feq, you can calculate: $feq / C0303 \times 16384$ then converts into hexadecimal. 16384 converts into hexadecimal is 0x4000. The reason to be multiplied 16384 is for a higher accuracy.

Receive data

Field	Description
01	FC address
0F	Function
00 00	Register address 0 is frequency converter control word.
00 20	The bit number is 32.
54 13	CRC check

12.7 Preset Multiple Regs

Example: Set C0303 = 60.000

Transmit: 01 10 0B D5 00 02 04 00 00 EA 60 02 B4 (Hexadecimal)

Receive: 01 10 0B D5 00 02 52 14 (Hexadecimal)

Transmit data

Field	Description
01	FC address
10	Function
0B D5	The register address of C0303 is $303 \times 10 - 1 = 3029$ (0x0BD5)
00 02	Register number
04	The byte number of data is 4
00 00 EA 60	0x0000EA60 convert to decimal number is 60000. So the value of C0303 is $60000 \times 0.001 = 60.000$
02 B4	CRC check

Receive data

Field	Description
01	FC address
10	Function
0B D5	The register address of C0303 is $303 \times 10 - 1 = 3029$ (0x0BD5)
00 02	Register number
52 14	CRC check

12.8 Read/Write array

Example: write parameter 3I[2] (index=2)

Transmit: 01 06 00 08 00 02 89 C9 (Hexadecimal)

Receive: 01 06 00 08 00 02 89 C9 (Hexadecimal)

Transmit: 01 10 0C 1B 00 01 02 00 00 69 BB (Hexadecimal)

Receive: 01 10 0C 1B 00 01 72 9E (Hexadecimal)

Transmit data 1

Field	Description
01	FC address
06	Function
00 08	Register address (ADDRH ADDRL), the register address of parameter index is 0x0008
00 02	The index is 2(0x0002)
89 C9	CRC check

Receive data 1

Field	Description
01	FC address
06	Function
00 08	Register address (ADDRH ADDRL), the register address of parameter index is 0x0008
00 02	The index is 2(0x0002)
89 C9	CRC check

Transmit data 2

Field	Description
01	FC address
10	Function
0C 1B	The register address of C0310 is $310*10-1=3099$ (0x0C1B)
00 01	Register number
02	Byte number
00 00	The value of $310[2]$ is 0
69 BB	CRC check

Receive data 2

Field	Description
01	FC address
10	Function
0C 1B	The register address of C0310 is $310 \times 10 - 1 = 3099$ (0x0C1B)
00 01	The number of register
72 9E	CRC check

12.9 Exception code

When a communication exception is happened, the inverter returns data format as following:

Address	Function	Exception code	CRC check
8 bits	8 bits	8 bits	16 bits

Exception code	Description
0x00	Parameter number does not exist
0x01	Defined parameters can not be written
0x02	The value exceeds the upper limit of the parameter
0x03	Index does not exist
0x04	The parameter is not array type
0x05	Data type exception
0x06	Only use for reset
0x07	Cannot be changed
0x0B	Not allowed to write
0x11	Data cannot be changed in the current mode(some parameter cannot be changed when the inverter is running)
0x12	Other exception
0x40	Invalid data address
0x41	Invalid length
0x42	Invalid length and value
0x43	Invalid parameter
0x82	The parameters has no bus connection
0x83	Factory settings, cannot be changed.