

**ILD-200
INFRARED REFRIGERANT
LEAK DETECTOR**



**SAE_J1627、 SAE_J2791、 SAE_J2913 ;
EN14624:2012 ; CE**

Table of Contents

Safety Precautions

First, the product description -----	3
1.1 Product Overview -----	3
1.2 detailed parameters -----	3
1.3 Accessories -----	4
Second, the instrument operation -----	5
2.1 panel display -----	5
2.2 key operation -----	5
2.3 leak detection -----	6
2.4 charge -----	7
Third, aftersales service and maintenance -----	8
3.1 Accessories -----	8
3.2 Filter replacement -----	8

First, the product description

1.1 Product overview

The ILD-200 is a hand-held leak detector that uses the infrared detection principle. Compared with the traditional leak detector, its sensor has longer life, higher detection accuracy, easy to operate and can detect a wider range of refrigerant. ILD-200 is equipped with large TFT LCD screen, so that the test results are more intuitive. The exclusive design of appearance is in accordance with human body mechanics to make it the best experience for users.

Product features are as bellow:

- ◆ Maximum sensitivity is less than 4g / yr
- ◆ L- M- H ,three levels of sensitivity adjustment
- ◆ Self-test function starts once power on
- ◆ Leakage peak recording function
- ◆ Electricity indication
- ◆ Sensor fault alarm
- ◆ TFT LCD display, display the leakage more intuitively
- ◆ UVLED Instantly light up, do not need warn-up and can achieve 100% power UV output
- ◆ Automatically shut down after 10 minutes no operation
- ◆ Shut off the hardware circuit function so that the battery can be used for longer time
- ◆ Open or close the buzzer in on button and can apply to all occasions
- ◆ Earphone function ensure that you can hear the alarm clearly even in a noisy environment
- ◆ Built-in high-capacity rechargeable lithium battery is more environmentally friendly and has longer service life
- ◆ Flexible probe, can used to detect in a narrow space

1.2 Detailed parameters

Sensor principle: Infrared spectrum absorption

Sensor life: 10 years

Sensitivity: max 4g / yr

Alarm mode: sound and light alarm, TFT LCD display

Automatic shutdown: 10 minutes without operation

Battery: built-in rechargeable lithium battery 3.7V 3000mAh

Working time: continuous 6H

Charging: 4 hours

Operating environment: -10 °C -52 °C relative humidity (50% ~ 85% RH)

Storage temperature: -20 °C to 60 °C (-4 °F to 140 °F)

Weight: 415g (14.6oz)

Size: 201mm * 86mm * 38mm (7.9" * 3.3" * 1.5")

Certification: SAE_J1627, SAE_J2791, SAE_J2913; EN14624: 2012; CE certification

1.3 Accessories

- 1, host
- 2, filter
- 3, USB charging cable
- 4, UV light

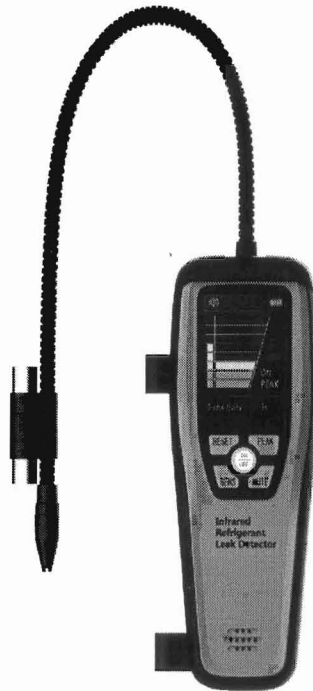

Second, instrument operations

2.1 Panel display

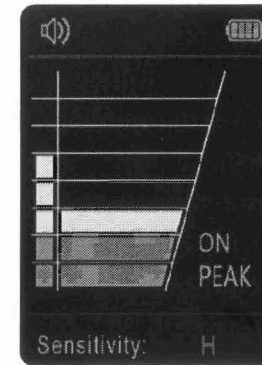

1. The power indicator: real-time instructions battery allowance
2. Buzzer mute indication: indicates the buzzer status. When opening the buzzer status in green, closing status in red
3. PEAK button instruction: indicates the PEAK function status, and the light will be on when you use this function
4. The maximum leak record: When the PEAK function is turned on, it can record the maximum leakage value you detect
5. The current leakage indicator: indicates the current leakage
6. Fault alarm: When the sensor failure, a fault indicator shows up
7. Warm-up countdown: warm-up time is 30 seconds. When the power is on it will show the warm-up process in countdown
8. The sensitivity level: display the current sensitivity level

2.2 Key operation

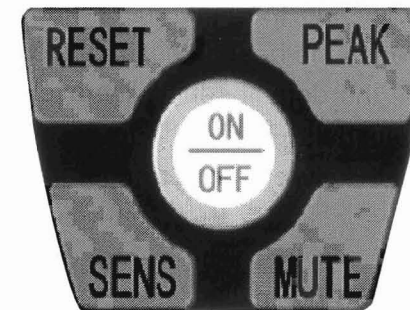

Switch key: press the button for 2 seconds to turn the instrument on or off.
 Reset key: Reset sensitivity benchmark to improve stability and sensitivity
 Mute key: press the mute button to turn on and off the buzzer
 Sensitivity adjustment key: press the sensitivity adjustment button to choose Low, Medium, High three different sensitivity levels
 TFT LCD display relative sensitivity level..
 Peak key: When it's continuous detection, PEAK function can record the maximum value of leakage. Press the peak button can turn on or off this function , the maximum value of the record is cleared when you turn off PEAK function.

2.3 leak detection

Test Precautions:

ILD-200 can detect relative concentrations. When the gas concentrations not change, it cannot detect the leakage. Therefore, keep the instrument moving during the test.

When the pressure in the system is very low, many refrigerant leaks cannot be detected. At the beginning of the test, ensure that the closed system pressure is at least 340Kpa (50psi) above.

Do not put the instrument near an organic solvent or cleaner, high voltage power supply. After the test, clean the instrument with a clean towel.

Steps

2.3.1 Open the instrument to confirm that the battery is sufficient for this test. Detection time about half an hour at a time

2.3.2 Turn on the power and the instrument starts to warm up. It takes about 30 seconds to reach the best detection state.

2.3.3 When turned on, the default sensitivity level is the highest. Set the different sensitivity levels by [SENS] bottom.

2.3.4 Locate the highly likely place of refrigerant leakage. Consider the following points:

- ◆ The node of the refrigerant pipeline

- ◆ The abnormal point of refrigerant pipe's cross section
- ◆ The abnormal points of refrigerant pipe's longitudinal section
- ◆ Visual tracking of the entire refrigeration system (all piping, hoses, fittings, couplings, service valves, etc.) looking for lubrication oil leakage, damage and corrosion signs, If it is present, may be a leak point.

2.3.5 Slowly move the probe (approximately 3 inch/sec or 75 mm/sec) at a distance of 0.25 inch (0.63 cm) near the suspected leak area. A closer probe position and a slower "sweep" movement usually raise the possibility of finding leaks.

The possibility of leakage.

The detected leakage intensity is proportional to the buzzer sound frequency. At the same time, the TFT LCD screen bar graph will show the leakage intensity from bottom to top.

2.3.6 Use the above method, carefully detect the entire system. If you find a leak, make a mark.

Query methods as shown

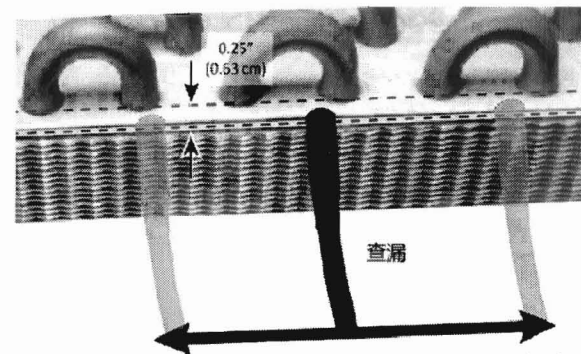

2.4 Battery charging

Precautions

- ◆ Avoid completely discharging the battery. Frequent charging of lithium batteries will affect the life.
- ◆ product built-in rechargeable lithium battery and it's strictly prohibited to replace the battery.

Charging parameters

Charging current: 5VDC 1A

When the battery is charged, the power indicator is as follows,

Charging status indication

Red light: charging

Blue light: charge is complete

Third, aftermarket and maintenance

Frequently Asked Questions and Solutions

Phenomenon	Solution
When Error is displayed	Sensor failure, replace the filter

3.1 Replace the filter element

Filter can filter large particles of pollutants and steam, reduce the false alarm caused by excessive humidity of product. When the filter is polluted, needs to be changed as soon as possible.

Filter position map

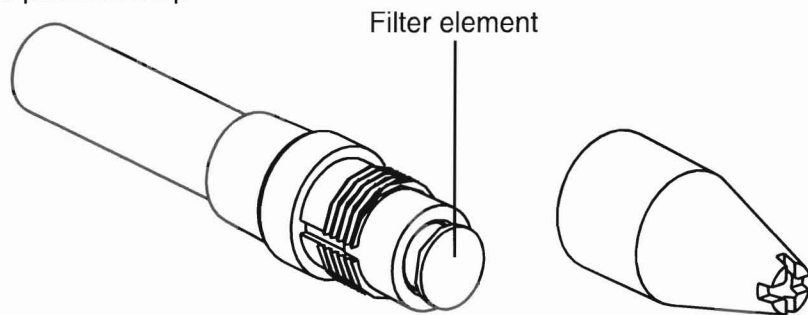

3.2 Need to charge the battery when long time no use to prevent self-discharge reduced battery life. The longest storage time is no more than 6 months.

3.3 Warranty 1 year

Do not disassemble yourself