

# Control Switch

## T Series Full Metal



Pilot Light



Non-illuminated  
Push Button Switch  
Flush head



Non-illuminated  
Push Button Switch  
Extended head unit



Illuminated LED  
Push Button Switch  
Flush head



Illuminated LED  
Push Button Switch  
Extended head unit



Non-illuminated  
Push Button Switch  
Flush head



Non-illuminated  
Push Button Switch  
Extended head unit



Non-illuminated  
Push Button Switch  
Dome



Illuminated LED  
Push Button Switch  
Flush head



Illuminated LED  
Push Button Switch  
Dome



Non-illuminated  
Selector Switch



Illuminated LED  
Selector Switch



Key Switch



Emergency Stop Switch



Illuminated Buzzer

## Part Number Description

T	①	②	③	④	⑤	⑥	⑦
① Panel Cut Size	16 : Ø16	19 : Ø19	22 : Ø22	25 : Ø25	30 : Ø30		
② Operator Type	2 : Momentary Push	3 : Maintained Push	4 : 2 Position Selector	5 : 3 Position Selector	6 : 2 Position Key	7 : 3 Position Key	8 : Emergency Stop A : Emergency Stop CZ : Buzzer
③ Illumination & Shape	1 : Non-illuminated Round	7 : Illuminated LED Round	CR : Continuous				
④ Contact Form	0 : No Contact	1 : 1N/O + 1N/C	2 : 2N/O + 2N/C				
⑤ Color	R : Red	G : Green	Y : Yellow	B : Blue	W : White		
⑥ Button Type	No mark : Flush Head	H : Extended Head	A : Dome				
⑦ Rated Voltage	D4 : 24VDC	A2 : 110/220VAC					

# Control Switch

## T Series Full Metal

### General Specification

	TYPE	T16	T19	T22, 25, 30	
General Ratings	Contact Resistance	Max. 50mΩ			
	Insulation Resistance	Min. 100MΩ (500VDC)			
	Dielectric Strength	2,000VAC for 1 minute			
	Vibration Resistance	5 - 55Hz dual amplitude : 0.75mm Operation			
	Shock Resistance	Endurance : 500m/s <sup>2</sup> , operation : 200m/s <sup>2</sup>			
	Life Cycles	Mechanical	Momentary : Min. 1,000,000		
			Maintained : Min. 250,000		
		Electrical	Momentary : Min. 100,000 (frequency of on/off 1,200 times / hour)		
			Maintained : Min. 50,000		
	Ambient Temperature	-25°C - +55°C (with no icing or condensation)			
	Ambient Humidity	45% - 85%RH			
	Degree of Protection	IP65 : PL, PB, PBL, EPB, EPBL		IP40 : K/S , S/S	
Terminal Soldering Temperature	20W 5sec / 260°C 3sec				
Contact Ratings	Contact Type	1N/O + 1N/C, 2N/O + 2N/C			
	Contact Material	Ag alloy (24K gold plate)			
	Rated Insulation Voltage	250VAC			
	Maximum Switching Current	Max. 3A		Max. 5A	
	Maximum Switching Voltage	250VAC, 110VDC			
	Current Rated	1A 24VDC / 120VAC		3A 24VDC / 120VAC	
		0.5A 250VAC		1.5A 250VAC	
Minimum Switching Current	1mA 5VDC				
Illumination	Lens Color	Red, Green, Yellow, Blue, White			
	Operator type	Round			
	Rated Voltage	24VDC, 110VAC, 220VAC			
	Rated Current	15mA approx.			
	Life Cycles <sup>1)</sup>	50,000hours			
Buzzer	Sound Type	Continuous, Alternating frequency			
	Volume	80dB (Phone)			
	Rated Voltage	24VDC			
	Rated Current	Approx. 15mA			
	Life Cycles	1,000 hours			
	Degree of Protection	IP40			

1) Luminance is reduced to 50% of initial intensity after being lit for 50,000 hours continuously.

Products Selection

	Operator Type	Panel Cutting Hole	Contact Form	LED Color	Rated Voltage	Part Number
	Non-Illuminated Momentary Push Button Flush head Switch	Ø 16	1N/O + 1N/C	-	-	T16-211
			2N/O + 2N/C	-	-	T16-212
	Non-Illuminated Maintained Push Button Flush head Switch	Ø 16	1N/O + 1N/C	-	-	T16-311
			2N/O + 2N/C	-	-	T16-312
	Non-Illuminated Momentary Push Button Extended head unit Switch	Ø 16	1N/O + 1N/C	-	-	T16-211H
			2N/O + 2N/C	-	-	T16-212H
	Non-Illuminated Maintained Push Button Extended head unit Switch	Ø 16	1N/O + 1N/C	-	-	T16-311H
			2N/O + 2N/C	-	-	T16-312H
	Illuminated LED Momentary Push Button Flush head Switch	Ø 16	1N/O + 1N/C	Red	24VDC	T16-271R D4
				Green		T16-271G D4
				Yellow		T16-271Y D4
				Blue		T16-271B D4
				White		T16-271W D4
	Ø 16	2N/O + 2N/C	Red	24VDC	T16-272R D4	
			Green		T16-272G D4	
			Yellow		T16-272Y D4	
			Blue		T16-272B D4	
			White		T16-272W D4	
	Ø 16	1N/O + 1N/C	Red	110/220VAC	T16-271R A2	
			Green		T16-271G A2	
			Yellow		T16-271Y A2	
			Blue		T16-271B A2	
			White		T16-271W A2	
	Ø 16	2N/O + 2N/C	Red	110/220VAC	T16-272R A2	
Green			T16-272G A2			
Yellow			T16-272Y A2			
Blue			T16-272B A2			
White			T16-272W A2			

Human-Machine Interface

# Control Switch

## T Series Full Metal

### Products Selection

	Operator Type	Panel Cutting Hole	Contact Form	LED Color	Rated Voltage	Part Number
	Illuminated LED Maintained Push Button Extended head Switch	Ø 16	1N/O + 1N/C	Red	24VDC	T16-371RH D4
				Green		T16-371GH D4
				Yellow		T16-371YH D4
				Blue		T16-371BH D4
				White		T16-371WH D4
	Ø 16	2N/O + 2N/C	24VDC	Red	T16-372RH D4	
				Green	T16-372GH D4	
				Yellow	T16-372YH D4	
				Blue	T16-372BH D4	
				White	T16-372WH D4	
Ø 16	1N/O + 1N/C	110/220VAC	Red	T16-371RH A2		
			Green	T16-371GH A2		
			Yellow	T16-371YH A2		
			Blue	T16-371BH A2		
			White	T16-371WH A2		
Ø 16	2N/O + 2N/C	110/220VAC	Red	T16-372RH A2		
			Green	T16-372GH A2		
			Yellow	T16-372YH A2		
			Blue	T16-372BH A2		
			White	T16-372WH A2		

Products Selection

	Operator Type	Panel Cutting Hole	Contact Form	LED Color	Rated Voltage	Part Number
	Non-Illuminated Momentary Push Button Flush head Switch	Ø 19	1N/O + 1N/C	-	-	T19-211
			2N/O + 2N/C	-	-	T19-212
	Non-Illuminated Maintained Push Button Flush head Switch	Ø 19	1N/O + 1N/C	-	-	T19-311
			2N/O + 2N/C	-	-	T19-312
	Non-Illuminated Momentary Push Button Extended head unit Switch	Ø 19	1N/O + 1N/C	-	-	T19-211H
			2N/O + 2N/C	-	-	T19-212H
	Non-Illuminated Maintained Push Button Extended head unit Switch	Ø 19	1N/O + 1N/C	-	-	T19-311H
			2N/O + 2N/C	-	-	T19-312H
	Non-Illuminated Momentary Push Button Dome Switch	Ø 19	1N/O + 1N/C	-	-	T19-211A
			2N/O + 2N/C	-	-	T19-212A
	Non-Illuminated Maintained Push Button Dome Switch	Ø 19	1N/O + 1N/C	-	-	T19-311A
			2N/O + 2N/C	-	-	T19-312A

Human-Machine Interface

# Control Switch

## T Series Full Metal

### Products Selection

	Operator Type	Panel Cutting Hole	Contact Form	LED Color	Rated Voltage	Part Number
	Illuminated LED Momentary Push Button Flush head Switch	Ø 19	1N/O + 1N/C	Red	24VDC	T19-271R D4
				Green		T19-271G D4
				Yellow		T19-271Y D4
				Blue		T19-271B D4
				White		T19-271W D4
		Ø 19	2N/O + 2N/C	Red	24VDC	T19-272R D4
				Green		T19-272G D4
				Yellow		T19-272Y D4
				Blue		T19-272B D4
				White		T19-272W D4
		Ø 19	1N/O + 1N/C	Red	110/220VAC	T19-271R A2
				Green		T19-271G A2
				Yellow		T19-271Y A2
				Blue		T19-271B A2
				White		T19-271W A2
Ø 19	2N/O + 2N/C	Red	110/220VAC	T19-272R A2		
		Green		T19-272G A2		
		Yellow		T19-272Y A2		
		Blue		T19-272B A2		
		White		T19-272W A2		
	Illuminated LED Maintained Push Button Extended head unithead Switch	Ø 19	1N/O + 1N/C	Red	24VDC	T19-371RH D4
				Green		T19-371GH D4
				Yellow		T19-371YH D4
				Blue		T19-371BH D4
				White		T19-371WH D4
		Ø 19	2N/O + 2N/C	Red	24VDC	T19-372RH D4
				Green		T19-372GH D4
				Yellow		T19-372YH D4
				Blue		T19-372BH D4
				White		T19-372WH D4
		Ø 19	1N/O + 1N/C	Red	110/220VAC	T19-371RH A2
				Green		T19-371GH A2
				Yellow		T19-371YH A2
				Blue		T19-371BH A2
				White		T19-371WH A2
Ø 19	2N/O + 2N/C	Red	110/220VAC	T19-372RH A2		
		Green		T19-372GH A2		
		Yellow		T19-372YH A2		
		Blue		T19-372BH A2		
		White		T19-372WH A2		

Products Selection

	Operator Type	Panel Cutting Hole	Contact Form	LED Color	Rated Voltage	Part Number
	Illuminated LED	Ø 19	1N/O + 1N/C	Red	24VDC	T19-271RA D4
	Momentary			Green		T19-271GA D4
	Push Button			Yellow		T19-271YA D4
	Dome Switch			Blue		T19-271BA D4
				White		T19-271WA D4
	Ø 19	2N/O + 2N/C	Red	24VDC	T19-272RA D4	
			Green		T19-272GA D4	
			Yellow		T19-272YA D4	
			Blue		T19-272BA D4	
			White		T19-272WA D4	
	Ø 19	1N/O + 1N/C	Red	110/220VAC	T19-271RA A2	
			Green		T19-271GA A2	
			Yellow		T19-271YA A2	
			Blue		T19-271BA A2	
			White		T19-271WA A2	
	Ø 19	2N/O + 2N/C	Red	110/220VAC	T19-272RA A2	
Green			T19-272GA A2			
Yellow			T19-272YA A2			
Blue			T19-272BA A2			
White			T19-272WA A2			

Human-Machine Interface

# Control Switch





## T Series Full Metal

### Products Selection

	Operator Type	Panel Cutting Hole	Contact Form	LED Color	Rated Voltage	Part Number
	Non-Illuminated 2 Position Selector Switch	Ø 19	1N/O + 1N/C	-	-	T19-411
			2N/O + 2N/C			T19-412
	Non-Illuminated 3 Position Selector Switch	Ø 19	2N/O + 2N/C		-	T19-512
	Illuminated LED 2 Position Selector Switch	Ø 19	1N/O + 1N/C	Red	24VDC	T19-471R D4
				Green		T19-471G D4
				Yellow		T19-471Y D4
				Blue		T19-471B D4
				White		T19-471W D4
	Ø 19	2N/O + 2N/C	Red	24VDC	T19-472R D4	
			Green		T19-472G D4	
			Yellow		T19-472Y D4	
			Blue		T19-472B D4	
			White		T19-472W D4	
	Ø 19	1N/O + 1N/C	Red	110/220VAC	T19-471R A2	
			Green		T19-471G A2	
Yellow			T19-471Y A2			
Blue			T19-471B A2			
White			T19-471W A2			
Ø 19	2N/O + 2N/C	Red	110/220VAC	T19-472R A2		
		Green		T19-472G A2		
		Yellow		T19-472Y A2		
		Blue		T19-472B A2		
		White		T19-472W A2		
	Illuminated LED 3 Position Selector Switch	Ø 19	2N/O + 2N/C	Red	24VDC	T19-572R D4
				Green		T19-572G D4
				Yellow		T19-572Y D4
				Blue		T19-572B D4
				White		T19-572W D4
	Ø 19	2N/O + 2N/C	Red	110/220VAC	T19-572R A2	
			Green		T19-572G A2	
			Yellow		T19-572Y A2	
			Blue		T19-572B A2	
			White		T19-572W A2	



Products Selection

Operator Type	Panel Cutting Hole	Contact Form	LED Color	Rated Voltage	Part Number
 <p>2 Position Key Switch</p>	Ø 19	1N/O + 1N/C	-	-	T19-611
		2N/O + 2N/C	-	-	T19-612
 <p>3 Position Key Switch</p>	Ø 19	2N/O + 2N/C	-	-	T19-712
 <p>Emergency Stop Switch</p>	Ø 19	1N/O + 1N/C	-	-	T19-811
		2N/O + 2N/C	-	-	T19-812
 <p>Emergency Stop Switch</p>	Ø 19	1N/O + 1N/C	-	-	T19-A11
		2N/O + 2N/C	-	-	T19-A12
 <p>Illuminated LED Buzzer</p>	Ø 19		Red	-	T19-CZCR

Human-Machine Interface



# Control Switch

## T Series Full Metal

### Products Selection

	Operator Type	Panel Cutting Hole	Contact Form	LED Color	Rated Voltage	Part Number
	Non-Illuminated Momentary Push Button Flush head Switch	Ø 22	1N/O + 1N/C	-	-	T22-211
			2N/O + 2N/C	-	-	T22-212
	Non-Illuminated Maintained Push Button Flush head Switch	Ø 22	1N/O + 1N/C	-	-	T22-311
			2N/O + 2N/C	-	-	T22-312
	Non-Illuminated Momentary Push Button Extended head unit Switch	Ø 22	1N/O + 1N/C	-	-	T22-211H
			2N/O + 2N/C	-	-	T22-212H
	Non-Illuminated Maintained Push Button Extended head unit Switch	Ø 22	1N/O + 1N/C	-	-	T22-311H
			2N/O + 2N/C	-	-	T22-312H

Products Selection

	Operator Type	Panel Cutting Hole	Contact Form	LED Color	Rated Voltage	Part Number	
	Illuminated LED Momentary Push Button Flush head Switch	Ø 22	1N/O + 1N/C	Red	24VDC	T22-271R D4	
				Green		T22-271G D4	
				Yellow		T22-271Y D4	
				Blue		T22-271B D4	
				White		T22-271W D4	
				2N/O + 2N/C	Red	24VDC	T22-272R D4
					Green		T22-272G D4
					Yellow		T22-272Y D4
					Blue		T22-272B D4
					White		T22-272W D4
	Illuminated LED Maintained Push Button Flush head Switch	Ø 22	1N/O + 1N/C	Red	24VDC	T22-371R D4	
				Green		T22-371G D4	
				Yellow		T22-371Y D4	
				Blue		T22-371B D4	
				White		T22-371W D4	
				2N/O + 2N/C	Red	24VDC	T22-372R D4
					Green		T22-372G D4
					Yellow		T22-372Y D4
					Blue		T22-372B D4
					White		T22-372W D4
			1N/O + 1N/C	Red	110/220VAC	T22-371R A2	
				Green		T22-371G A2	
				Yellow		T22-371Y A2	
				Blue		T22-371B A2	
				White		T22-371W A2	
			2N/O + 2N/C	Red	110/220VAC	T22-372R A2	
				Green		T22-372G A2	
				Yellow		T22-372Y A2	
				Blue		T22-372B A2	
				White		T22-372W A2	

Human-Machine Interface

# Control Switch

## T Series Full Metal

### Products Selection

	Operator Type	Panel Cutting Hole	Contact Form	LED Color	Rated Voltage	Part Number
	Non-Illuminated Momentary Push Button Flush head Switch	Ø 25	1N/O + 1N/C	-	-	T25-211
			2N/O + 2N/C	-	-	T25-212
	Non-Illuminated Maintained Push Button Flush head Switch	Ø 25	1N/O + 1N/C	-	-	T25-311
			2N/O + 2N/C	-	-	T25-312
	Non-Illuminated Momentary Push Button Extended head unit Switch	Ø 25	1N/O + 1N/C	-	-	T25-211H
			2N/O + 2N/C	-	-	T25-212H
	Non-Illuminated Maintained Push Button Extended head unit Switch	Ø 25	1N/O + 1N/C	-	-	T25-311H
			2N/O + 2N/C	-	-	T25-312H

Products Selection

	Operator Type	Panel Cutting Hole	Contact Form	LED Color	Rated Voltage	Part Number	
	Illuminated LED Momentary Push Button Flush head Switch	Ø 25	1N/O + 1N/C	Red	24VDC	T25-271R D4	
				Green		T25-271G D4	
				Yellow		T25-271Y D4	
				Blue		T25-271B D4	
				White		T25-271W D4	
				2N/O + 2N/C	Red	24VDC	T25-272R D4
					Green		T25-272G D4
					Yellow		T25-272Y D4
					Blue		T25-272B D4
					White		T25-272W D4
	Illuminated LED Maintained Push Button Flush head Switch	Ø 25	1N/O + 1N/C	Red	24VDC	T25-371R D4	
				Green		T25-371G D4	
				Yellow		T25-371Y D4	
				Blue		T25-371B D4	
				White		T25-371W D4	
				2N/O + 2N/C	Red	24VDC	T25-372R D4
					Green		T25-372G D4
					Yellow		T25-372Y D4
					Blue		T25-372B D4
					White		T25-372W D4
			1N/O + 1N/C	Red	110/220VAC	T25-371R A2	
				Green		T25-371G A2	
				Yellow		T25-371Y A2	
				Blue		T25-371B A2	
				White		T25-371W A2	
			2N/O + 2N/C	Red	110/220VAC	T25-372R A2	
				Green		T25-372G A2	
				Yellow		T25-372Y A2	
				Blue		T25-372B A2	
				White		T25-372W A2	

Human-Machine Interface





# Control Switch

## T Series Full Metal

### Products Selection

	Operator Type	Panel Cutting Hole	Contact Form	LED Color	Rated Voltage	Part Number
	Non-Illuminated Momentary Push Button Flush head Switch	Ø 30	1N/O + 1N/C	-	-	T30-211
			2N/O + 2N/C	-	-	T30-212
	Non-Illuminated Maintained Push Button Flush head Switch	Ø 30	1N/O + 1N/C	-	-	T30-311
			2N/O + 2N/C	-	-	T30-312
	Non-Illuminated Momentary Push Button Extended head unit Switch	Ø 30	1N/O + 1N/C	-	-	T30-211H
			2N/O + 2N/C	-	-	T30-212H
	Non-Illuminated Maintained Push Button Extended head unit Switch	Ø 30	1N/O + 1N/C	-	-	T30-311H
			2N/O + 2N/C	-	-	T30-312H

Products Selection

	Operator Type	Panel Cutting Hole	Contact Form	LED Color	Rated Voltage	Part Number
	Illuminated LED Momentary Push Button Flush head Switch	Ø 30	1N/O + 1N/C	Red	24VDC	T30-271R D4
				Green		T30-271G D4
				Yellow		T30-271Y D4
				Blue		T30-271B D4
				White		T30-271W D4
			2N/O + 2N/C	Red	24VDC	T30-272R D4
				Green		T30-272G D4
				Yellow		T30-272Y D4
				Blue		T30-272B D4
				White		T30-272W D4
			1N/O + 1N/C	Red	110/220VAC	T30-271R A2
				Green		T30-271G A2
				Yellow		T30-271Y A2
				Blue		T30-271B A2
				White		T30-271W A2
			2N/O + 2N/C	Red	110/220VAC	T30-272R A2
Green	T30-272G A2					
Yellow	T30-272Y A2					
Blue	T30-272B A2					
White	T30-272W A2					
	Illuminated LED Maintained Push Button Flush head Switch	Ø 30	1N/O + 1N/C	Red	24VDC	T30-371R D4
				Green		T30-371G D4
				Yellow		T30-371Y D4
				Blue		T30-371B D4
				White		T30-371W D4
			2N/O + 2N/C	Red	24VDC	T30-372R D4
				Green		T30-372G D4
				Yellow		T30-372Y D4
				Blue		T30-372B D4
				White		T30-372W D4
			1N/O + 1N/C	Red	110/220VAC	T30-371R A2
				Green		T30-371G A2
				Yellow		T30-371Y A2
				Blue		T30-371B A2
				White		T30-371W A2
			2N/O + 2N/C	Red	110/220VAC	T30-372R A2
Green	T30-372G A2					
Yellow	T30-372Y A2					
Blue	T30-372B A2					
White	T30-372W A2					

Human-Machine Interface

# Control Switch

## T Series Full Metal

### Dimension

(mm)

T16 Series - Ø16

Non-Illumination Push Button Switch (Flush)

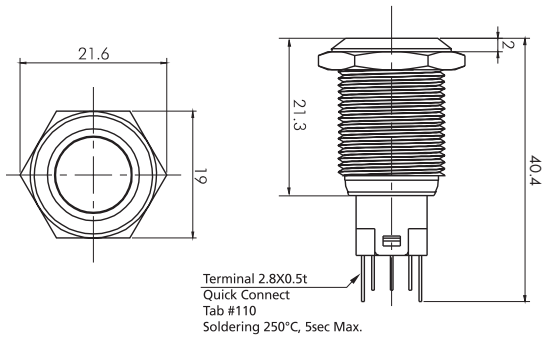

Non-Illumination Push Button Switch (Extended)

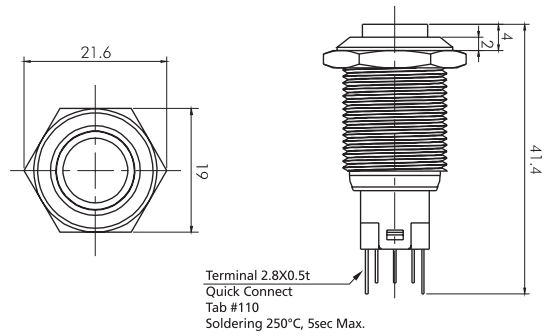

LED Illumination Push Button Switch (Flush)

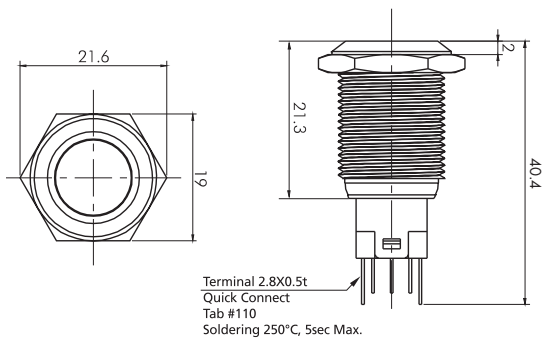

LED Illumination Push Button Switch (Extended)

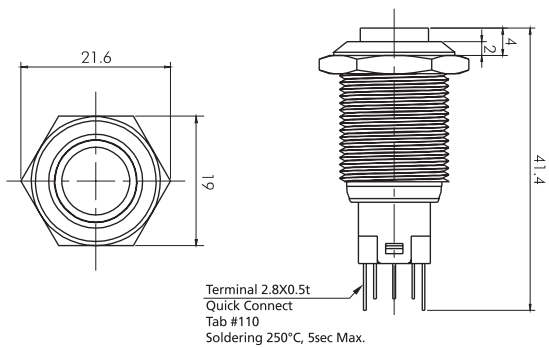

Wiring Diagram

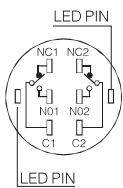

Panel cut-out

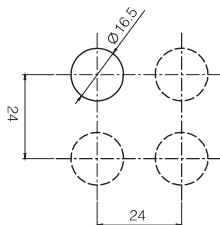



Dimension

(mm)

T19 Series - Ø19

LED Pilot lamp (Flush)

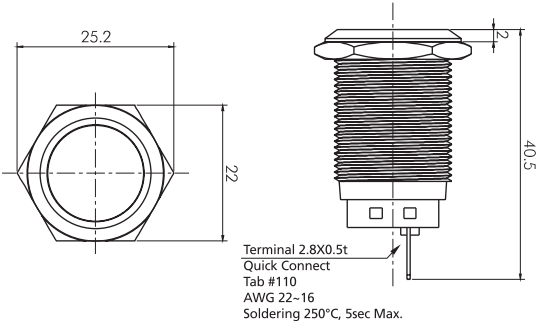

LED Pilot lamp (Dome)

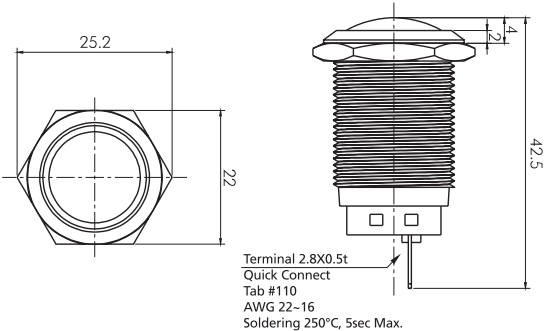

Non-Illumination Push Button Switch (Flush)

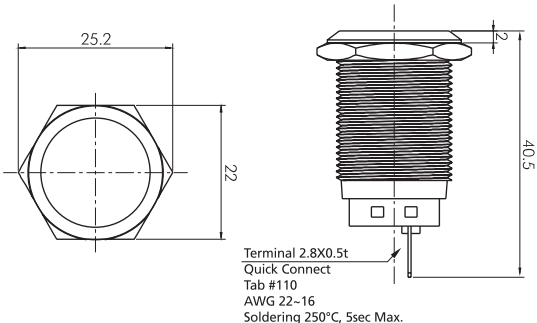

Non-Illumination Push Button Switch (Extended)

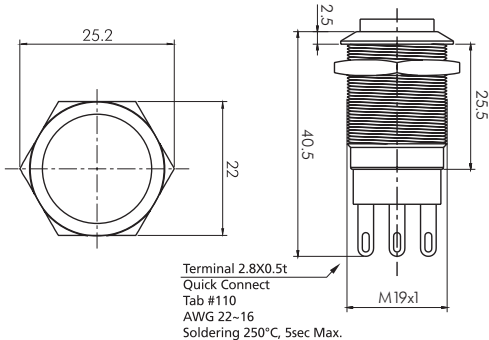

Non-Illumination Push Button Switch (Dome)

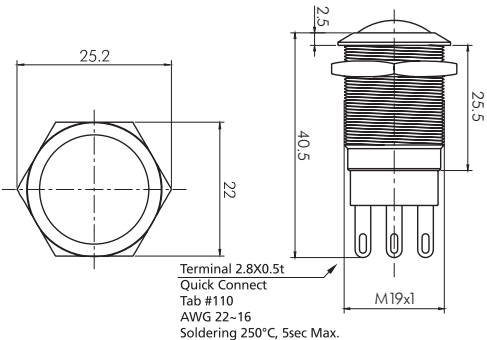

LED Illumination Push Button Switch (Flush)

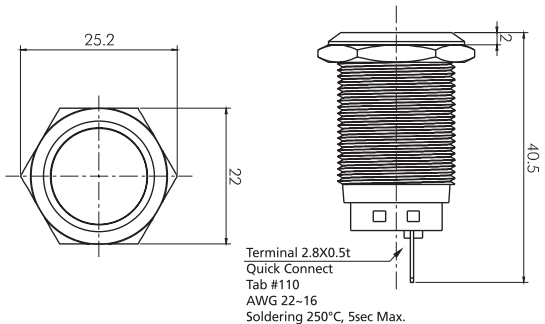

Human-Machine Interface



# Control Switch

## T Series Full Metal

### Dimension

(mm)

#### T19 Series - Ø19

##### LED Illumination Push Button Switch (Dome)

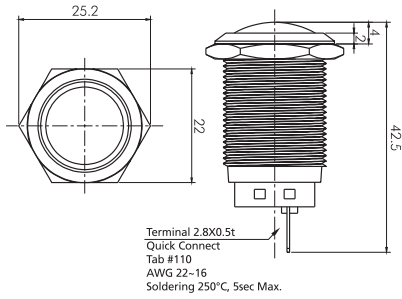

##### Selector Switch

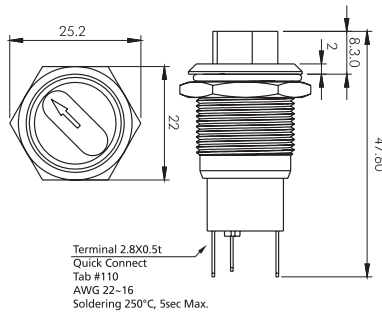

##### Key Switch

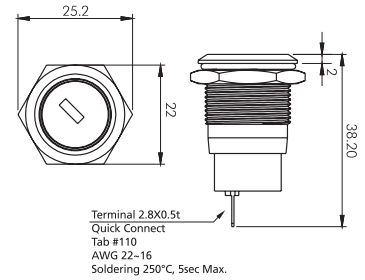

##### Emergency Switch (T19-8 Type)

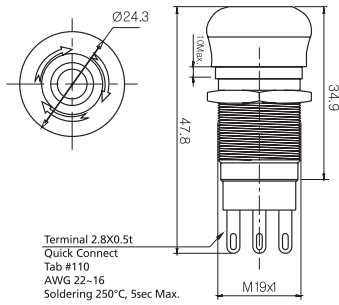

##### Emergency Switch (T19-A Type)

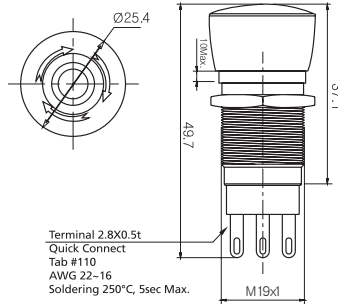

##### LED Illumination Buzzer

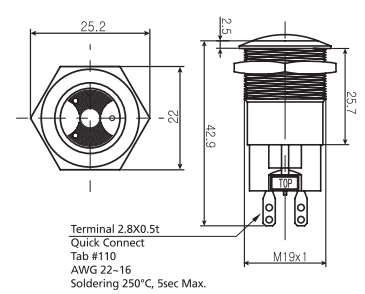

#### Wiring Diagram

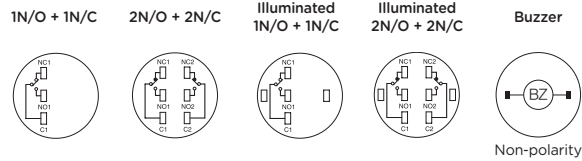

#### Panel cut-out

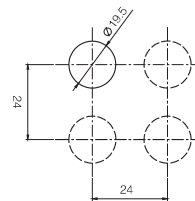

Dimension

(mm)

T22 Series - Ø22

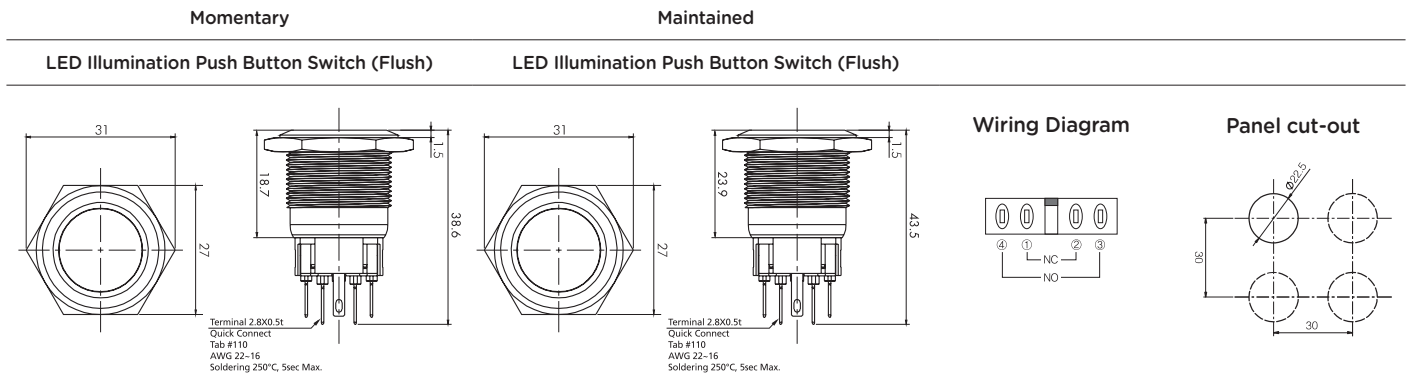
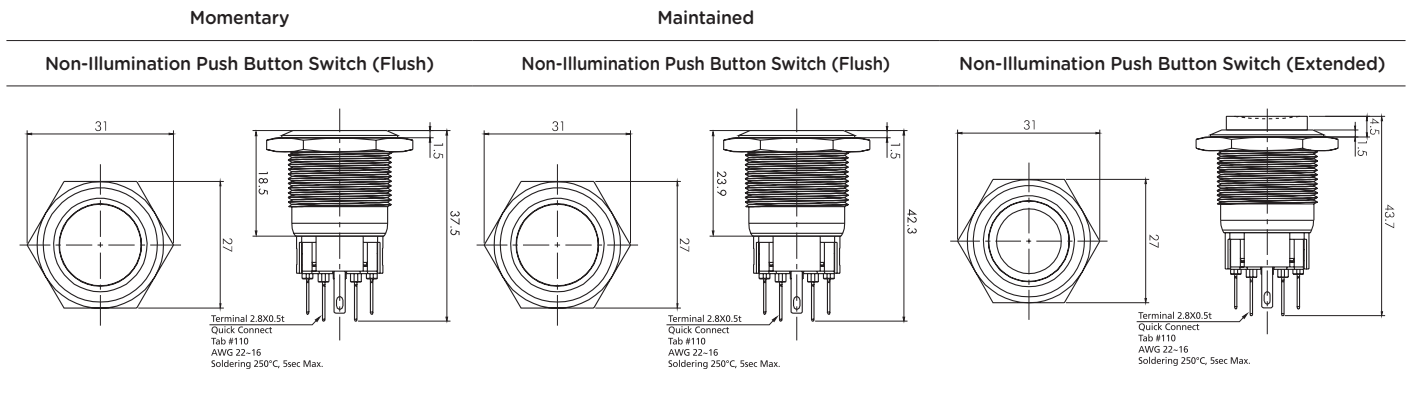

T25 Series - Ø25

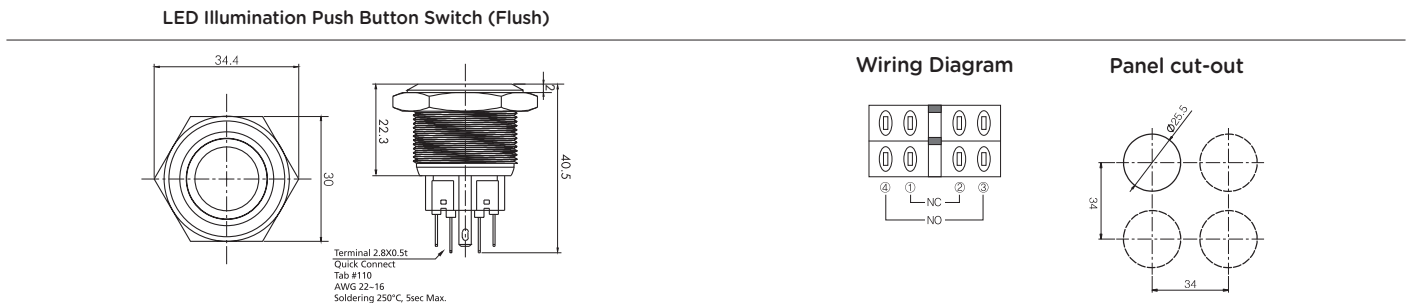
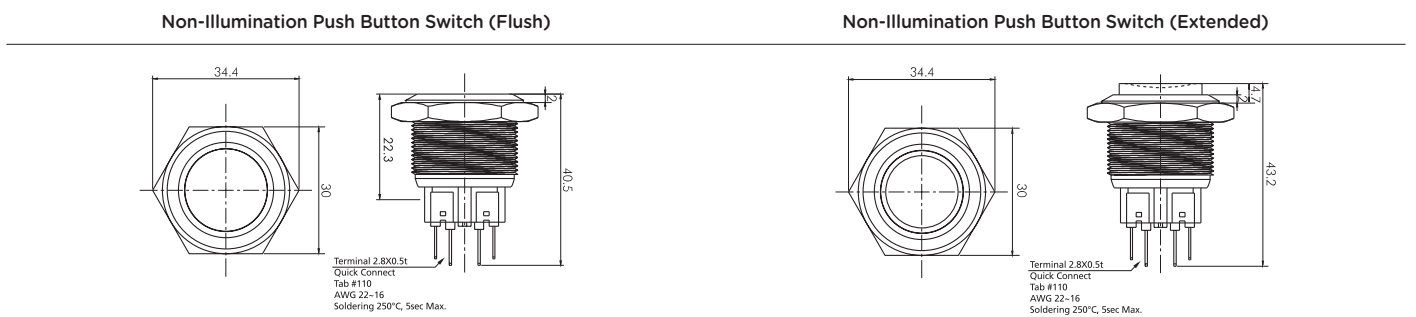

# Control Switch

## T Series Full Metal

### Dimension

(mm)

#### T30 Series - Ø30

Non-Illumination Push Button Switch (Flush)

Non-Illumination Push Button Switch (Extended)

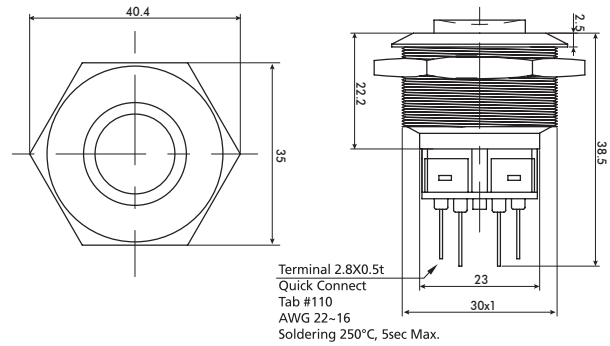
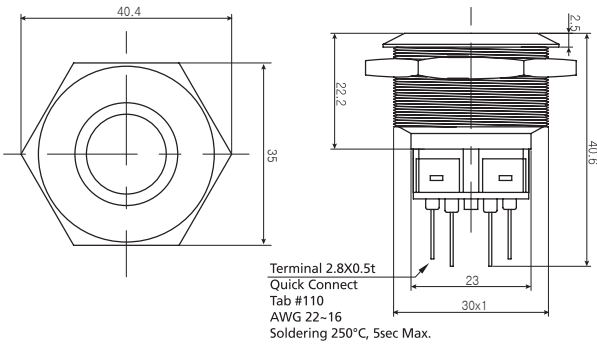

LED Illumination Push Button Switch (Flush)

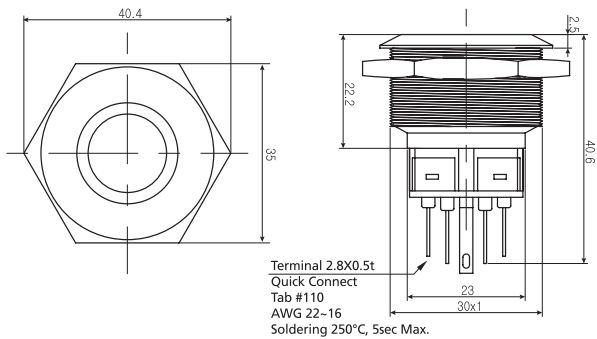

Wiring Diagram

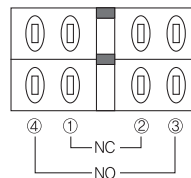

Panel cut-out

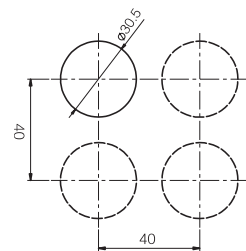

#### Accessory : FIX Plate

T - P1 (Ø19, 22, 25, 30)

T - P2 (Ø19 only)

T - P3 (Ø16 only)

