

# Introduction and Manual

## Two-dimensional TOF Laser Scanner

Model: N301 series LiDAR



product by: LS Lidar



## Introduction

N301 series laser scanner adopts TOF (time of flight) principle and can realize two-dimensional scanning and detection to the surrounding 360-degree environment. This series laser scanner transmits electric energy and laser scanner internal data in a wireless way. This series is classified into N30101, N30103, N30105, N30110, N30120 and other models according to the measuring range, the measuring frequency can reach 20 KHZ, and the laser scanner with higher frequency may be customized. The design detection accuracy is +/- 3cm, and the maximum measuring range ranges from 10 meters to 200 meters. As the low-cost solution, this series laser scanner is mainly used for indoor/outdoor service robots, AGV, Cleaning Robot, UAV, automobile ADAS systems and other applications.



## Technical Parameters

Item	N30101	N30101B	N30101C	N30103A	N30103B	N30105A	N30105B	N30110	N30120
Angular resolution	0.18°~0.45°	0.05°~0.2°	0.27°~1°	0.18°~0.45°	0.05°~0.2°	0.18°~0.45°	0.05°~0.2°	0.09°~0.54°	0.09°~0.54°
Scan Frequency	10~25 Hz	3~11Hz	3~11Hz	10~25Hz	3~11Hz	10~25Hz	3~11Hz	5~25Hz	
Sampling Frequency	20KHz		4000Hz	20KHz (customizable)					
Measurement Accuracy	+/- 3cm								
Laser	90								
Detection distance	10m			30m		50m		100m	200m
Data Content	Distance、Degree、Intensity of return light								
Power Supply	9V~36V								
Motor	Brushless motor								
Communication Interface	Ethernet		RS232	Ethernet					
Size (mm)	Φ80*79.1								



## Principle

N301 series adopts TOF (time of flight) principle, and measures the relative distance between the object and the sensor by measuring the modulated laser emission and return time difference. The laser transmitter emits the modulated pulse laser, and the internal timer starts to count the time  $t_1$ . When the laser irradiates the target object, part of energy returns. When the laser receives the returned laser signal, the internal timer  $t_2$  is stopped, and the distance from the laser scanner to the object is:

$$S=C(\text{speed of light}) * (t_2-t_1) / 2$$

$$S=C (\text{laser speed}) * (t_2-t_1) / 2$$

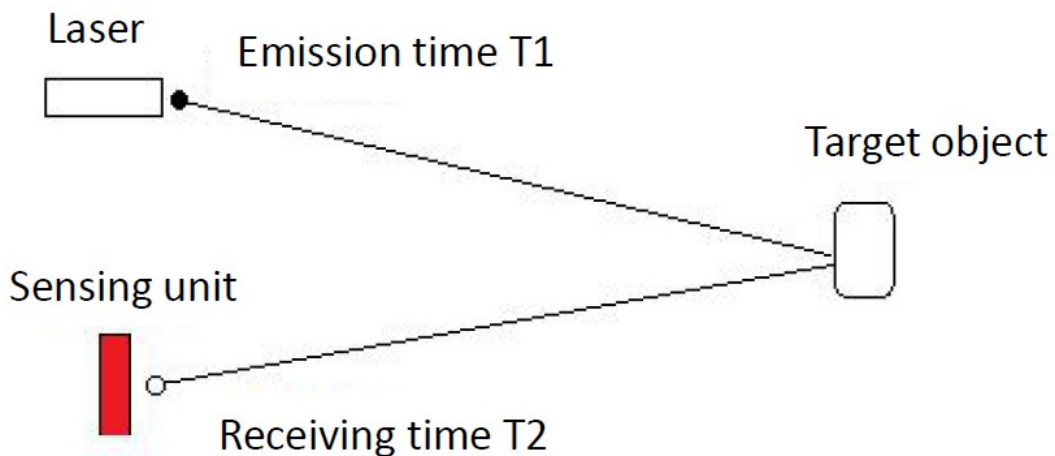

According to the distance to the detected object calculated in real time by the signal processing unit embedded in N301 series laser scanner and in combination with the angle information outputted by the high precision adaptive angle measurement module, the two-dimensional plane information of the surrounding 360-degree environment can be obtained within the measuring range.

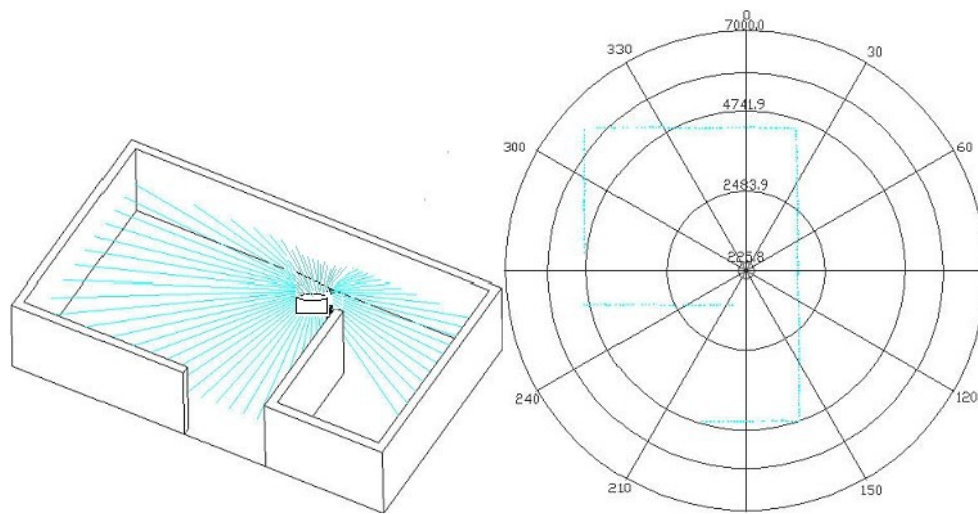

Effect Diagram for 360-degree Two-dimensional Plane Detected by N301 Laser Scanner



## Component Connection

N301 series laser scanner is mainly composed of a laser transceiver module, a TOF weak signal detection module, a signal processing module, a data/command transmission interface, etc. The internal power supply of the system is 5V DC power supply. N30101, N30103, N30105, N30110, N30120 and other laser scanners use 9-36V wide external power supply. Users can configure the output mode, scanning frequency, angular resolution and other parameters of the laser scanner through commands. Users can directly dock with FPGA/DSP/ARM and other control cards through the transmission interface to realize rapid, real-time command and data interaction. After the system is powered on correctly, users can obtain the scanned ranging data by calling the drive program of N301 series laser scanner.



N301 series laser scanner system is provided with a speed stabilization function. Users can set the scanning frequency through a command, and the system will automatically obtain the speed information in real time. The internal speed stabilization system will adjust the torsion according to the real-time speed, so that the system steadily runs at the scanning frequency set by the user, and the system has strong ability to adapt to the changes of temperature fluctuation, vibration, altitude and other external conditions.



## Data message format

When N301 series laser scanner works, each set of sampled data is outputted through the communication interface. The output data has a unified message format. If you want to know detailed communication protocol and data message format, please contact us.

Data Type	Unit	Description
Distance value	mm	Actual distance between N301 series laser scanner and current sampling point
Angle	Degree	Angle of current sampling point relative to N301 polar coordinates
New data frame zone bit	(Boolean value)	Indicating whether the current sampling point is scanned again

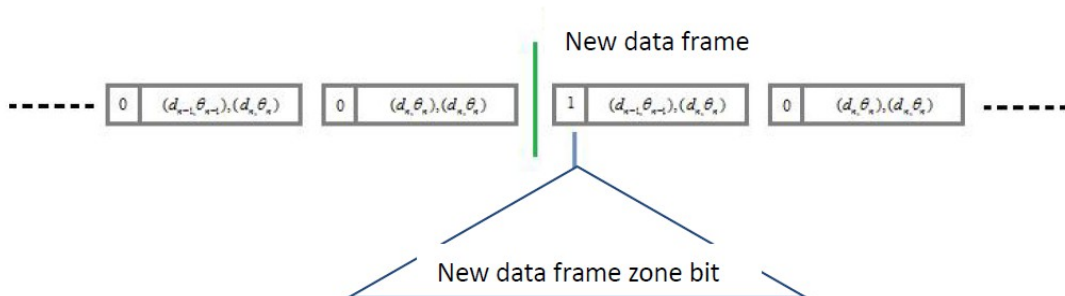

The measurement data of N301 series laser scanner is output in a message format. The external system can control the laser scanner to output the data through request, stop and other commands or configure the format of output data.



## Application Example

This system is suggested to be used in the following fields:

- Navigation and positioning of movable robot
- Navigation and obstacle avoidance of unmanned aerial vehicle
- Simultaneous localization and mapping (SLAM) platform
- AGV (Automatic Guided Vehicle)
- Driving system of unmanned vehicle
- Automobile driver assistance





## Safety and Product Protection

N301 series laser scanner uses 905nm pulse infrared laser as an emission light source, and is driven in a modulating pulse mode, and the laser power conforms to the safety level of CLASS I. The laser emission unit of the laser scanner emits laser only when the system rotates at high speed. The actual laser power received within the unit time at the fixed point is far lower than CLASS I laser safety standard, ensuring the safety of humans and pets.

In order to avoid the abrupt change of laser power caused by the external impact and abnormal work of the laser scanner and ensure that the laser power output is always within the safe output range of CLASS I, we design the function of product protection module. When the following faults occur, the laser scanner will turn off the laser output and stop scanning the range to avoid the damage to itself and the outside.

- The transmitting power of the laser exceeds the threshold value;
- The laser cannot work;
- TOF ranging unit works abnormally;
- The scanning speed of the laser scanner is too low;
  
- The motor speed is not stable. The external system can inquire the working status of the device through the communication interface and can recover the normal working status through pause, restart and other commands.



## Performance Parameters

	Unit	Min	Standard	Max	Note
Laser wavelength	nm	895	905	9	infrared band
Laser power	mW	-	<1	-	Average power
Pulse Duration	μs	-	7	10	
Detection range	m	-	<u>10m</u> <u>30m</u> <u>50m</u> <u>100m</u> <u>200m</u>	-	
Absolutely measurement accuracy	cm	-	+/-3cm	-	
Angular resolution	Deg	0.18° 0.05 0.27° 0.09°	— — — —	0.45° 0.2° 1° 0.54°	N30101A、N30103A N30105A N30105B N30101C N30110、N30120
Every ranging time	ms	-	250 50	-	N30101C N30101A、N30101B N30103A、N30103B N30105A、N30105B N30110、N30120
Sampling Frequency	Hz	-	4,000 20,000	-	N30101C N30101A,N30101B
Scan	Hz	3 10 3 5	10 20 10 20	11 25 11 25	N30101B、N30103B N30105B N30101A、N30103A N30105A N30101C N30110、N30120



## Communication and Interfaces

In N301 series laser scanner products, N30101 communication interface includes UART (serial port) and 485 interfaces, and other interfaces are Ethernet interfaces, such as N30103A, N30103B, N30105A, N30105B, N30110, N30130 and N30150. The requirements for lead definition and signal level of different interfaces are as follows:

### Ethernet UART port (serial port)

N30101C uses RS232 serial port as the communication interface, and can use RS485, I2C, SPI, USB and other interfaces as required by the user. The following table shows the specification information on UART serial port interface. If you want to get SDK, detailed communication protocols, parameter customization information, etc., please contact us.

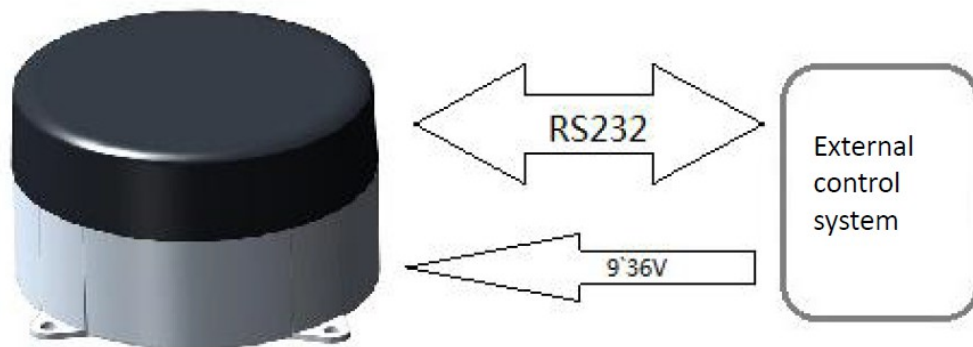

Item	Unit	Minimum	Typical Value	Maximum	Remark
Baud rate	bps	-	230400	-	RS232 communication frequency
Working mode	-	-	8-bit data, 1 stop bit, without checking	-	
Input power voltage	Volt (v)	9V	12V	36V	9-36V wide power input
Power ripple	Volt (v)	—	100mV	300mV	Input power ripple



## Ethernet port

Ethernet interfaces of N301 series laser scanners (except that N30101C uses RS232) uses a port with bandwidth of 100 MB as the communication interface, and can realize the real-time and high-speed transmission of mass data. The following table shows the specification information on ports. If you want to get SDK, detailed communication protocols, parameter customization information, etc., please contact us.

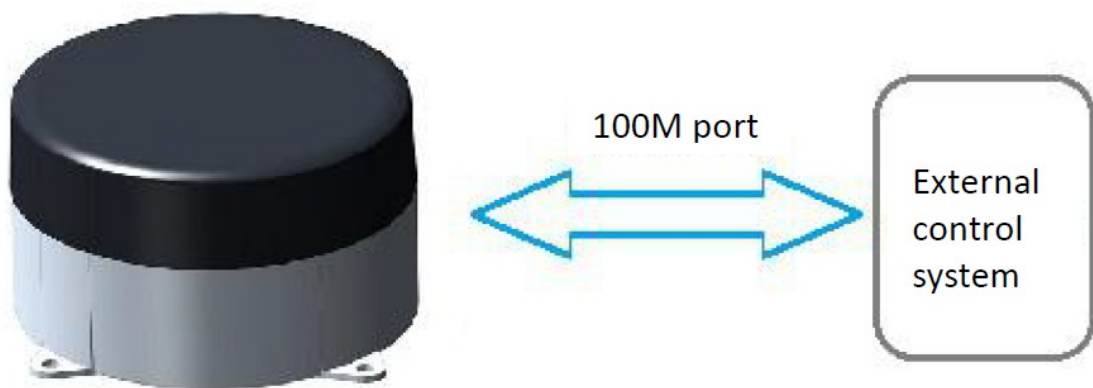

Item	Unit	Minimum	Typical Value	Maximum	Remark
Bandwidth	bps	-	100M	-	Communication bandwidth
Working mode	-	-	Tcp-server	-	
IP address			192.168.1.1		IP address can be changed
Subnet mask			255.255.255.0		Set as required
Gateway address			192.168.1.1		Set as required



## Power Supply Information

N301 series laser scanner uses 9-36V wide voltage power supply mode. The external power supply can normally work at 9-36V, but it is suggested to use the low ripple power supply to obtain a stable data output.

Item	Unit Remark	Minimum	Typical Value		Maximum
System voltage	Volt (v)	9	12	36	It is suggested to use the low ripple power supply.
Measuring module current	Milliampere (mA)		350	Pending	
			Pending (12V power supply)		



## Development Tool and Support

LS LIDAR provides SDK development kits supporting 301 series products for customers to process the scanned data in real time and display in the form of image. SDK development kits for N301 series products facilitate the users to be familiar with this product and help shorten the project development cycle. Currently, only SDK kits for Linux, ROS and Windows X86 platforms are available. Later on, SDK kits for Android, mac os and other platforms will be released. Please refer to the official website <http://en.leishen-lidar.com> for latest release.

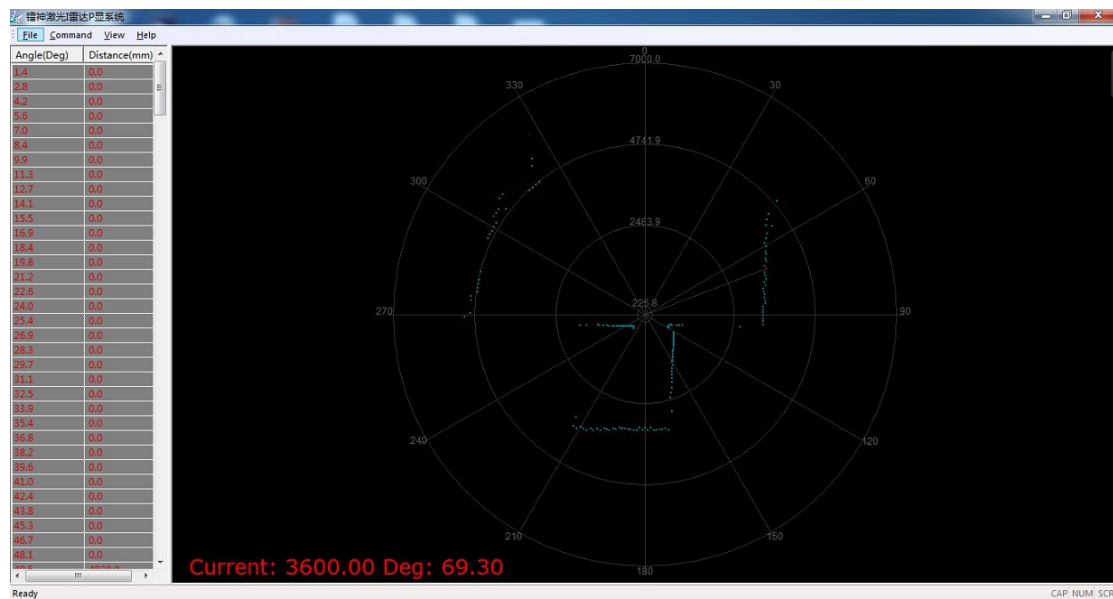

# Dimension

In order to facilitate the users to integrate the product, some parts of N301 series laser scanner can be customized according to the user's requirements. The diagram for installation mechanism is shown below.

